

---

# DP5700 Series

## System DC Power Supplies

### 1.5 kW

DP5721A, DP5722A, DP5723A, DP5724A, DP5726A,  
DP5728A, DP5730A, DP5731A, DP5733A, DP5736A

### 3.4 kW

DP5741AS/AL/AH, DP5742AS/AL/AH, DP5743AS/AL/AH,  
DP5744AS/AL/AH, DP5746AS/AL/AH, DP5748AS/AL/AH,  
DP5750AS/AL/AH, DP5751AS/AL/AH, DP5753AS/AL/AH,  
DP5756AS/AL/AH

### 5 kW

DP5761AL/AH, DP5762AL/AH, DP5763AL/AH, DP5764AL/AH,  
DP5765AL/AH, DP5766AL/AH, DP5768AL/AH, DP5770AL/AH,  
DP5771AL/AH, DP5772AL/AH, DP5773AL/AH, DP5774AL/AH,  
DP5775AL/AH, DP5776AL/AH



Mess- und Prüftechnik. Die Experten.

Ihr Ansprechpartner /  
Your Partner:

dataTec AG  
E-Mail: [info@datatec.eu](mailto:info@datatec.eu)  
[datatec.eu](http://datatec.eu)





<b>Legal and Safety Information</b> .....	<b>7</b>
<b>Legal Notices</b> .....	<b>7</b>
<b>Safety and Regulatory Symbols</b> .....	<b>8</b>
<b>Safety Notices</b> .....	<b>9</b>
<b>Symboles de sécurité</b> .....	<b>13</b>
<b>1 Quick Reference</b> .....	<b>17</b>
<b>Models and Options</b> .....	<b>18</b>
Model Ratings .....	18
Accessories/Options .....	19
<b>Introduction to the Instrument</b> .....	<b>20</b>
Front Panel at a Glance .....	21
Front Panel Display at a Glance .....	23
Rear Panel at a Glance .....	24
J1 Connector Pin Functions .....	25
<b>Front Panel Menu</b> .....	<b>26</b>
<b>2 Installing the Instrument</b> .....	<b>29</b>
<b>Before Installation or Use</b> .....	<b>30</b>
Inspect the Unit .....	30
Check for Items Supplied .....	31
Review Safety Information .....	33
Observe Environmental Conditions .....	33
Provide Adequate Air Flow .....	33
Desk Top Use .....	33
<b>Rack Mounting</b> .....	<b>34</b>
Rack Mounting a Single 1.5 kW Unit .....	35
Rack Mounting Dual 1.5 kW Units .....	38
Rack Mounting 3.4 kW, 5 kW Units .....	40
<b>AC Mains Connections</b> .....	<b>42</b>
Power Cables .....	42
Power Connections .....	42
<b>Single Unit Connections</b> .....	<b>45</b>
Output Connections .....	45
Single Load Connections .....	47
Ferrite Core Installation - for 1.5 kW models only .....	50
Load Cable and Safety Cover Instructions .....	51
Output Voltage Sensing .....	55
Load Considerations .....	56
Grounding the Output .....	57
<b>Multiple Unit Connections</b> .....	<b>59</b>
Parallel Connections .....	59
Series Connections .....	63
<b>External Control Signal Connections (Analog)</b> .....	<b>66</b>
Pin Assignments .....	66
<b>3 Using the Power Supply Locally</b> .....	<b>67</b>
<b>Turn-On Checkout</b> .....	<b>68</b>

Before Turn-On .....	68
Constant Voltage Check .....	69
OVP Check .....	69
UVL Check .....	70
Constant Current Check .....	70
<b>Programming the Output .....</b>	<b>71</b>
Set the Output Voltage .....	72
Set the Output Current .....	72
Set the Output Power .....	73
Enable the Output .....	73
<b>Protection Functions .....</b>	<b>74</b>
Set the Over-Voltage Protection .....	74
Set the Under-Voltage Protection .....	75
Set the Over-Current Protection .....	76
Additional Protections .....	77
Protection Clear .....	77
<b>External Control Signal Programming .....</b>	<b>78</b>
Analog Programming of Voltage and Current .....	78
Analog Monitoring of Voltage and Current .....	80
Analog Overcurrent Limit .....	81
Interlock Function .....	81
Output Enable/Disable .....	82
Monitoring Output Status .....	83
Monitoring CV/CC Status .....	84
Auxiliary Signals Prog_out_1 and Prog_out_2 .....	84
Daisy-Chained Output Shutdown .....	85
<b>Parallel System Operation .....</b>	<b>86</b>
<b>System Operations .....</b>	<b>87</b>
Instrument Triggering .....	87
Internal Resistance .....	89
Constant Power Limit .....	90
Slew-Rate Control .....	92
Instrument Identification .....	92
Instrument State Storage .....	93
Front Panel Lock-Out .....	93
<b>4 Using the Power Supply Remotely .....</b>	<b>94</b>
<b>Programming the Interfaces .....</b>	<b>95</b>
USB Configuration .....	95
GPIB Configuration .....	95
LAN Configuration .....	95
Using the Web Interface .....	98
Using Telnet .....	98
Using Sockets .....	99
<b>Programming Output Lists .....</b>	<b>100</b>
Program the List Levels .....	102
Program the List Dwell Times .....	103
Specify the List Pacing .....	103

Program the List Generated Trigger Signals .....	104
Specify the List Repeat Count .....	104
Voltage List Example .....	105
<b>Introduction to the SCPI Language .....</b>	<b>106</b>
Command Types .....	106
Keywords .....	107
Queries .....	107
Command Separators and Terminators .....	107
Syntax Conventions .....	108
Parameter Types .....	109
Device Clear .....	110
<b>5 SCPI Programming Reference .....</b>	<b>112</b>
<b>Command Quick Reference .....</b>	<b>113</b>
<b>Abort Command .....</b>	<b>117</b>
<b>Analog Commands .....</b>	<b>117</b>
<b>Common Commands (IEEE-488) .....</b>	<b>118</b>
<b>Current Commands .....</b>	<b>125</b>
<b>Digital Commands .....</b>	<b>127</b>
<b>Display Command .....</b>	<b>128</b>
<b>Initiate Commands .....</b>	<b>129</b>
<b>Instrument Commands .....</b>	<b>130</b>
<b>List Commands .....</b>	<b>131</b>
<b>LXI Commands .....</b>	<b>133</b>
<b>Measure Commands .....</b>	<b>134</b>
<b>Output Commands .....</b>	<b>135</b>
<b>Power Commands .....</b>	<b>138</b>
<b>Slew Commands .....</b>	<b>138</b>
<b>Status Commands .....</b>	<b>139</b>
<b>System Commands .....</b>	<b>146</b>
<b>Trigger Commands .....</b>	<b>153</b>
<b>Voltage Commands .....</b>	<b>154</b>
Reset State (*RST) .....	158
SCPI Error Messages .....	160
<b>6 Option DP5705A (SD Card Option) .....</b>	<b>166</b>
Option DP5705A Description .....	167
Option Installation .....	167
Basic Operation .....	167
SD Card Data Storage .....	168
SD Card Insertion and Removal .....	168
Option DP5705A Behavior When a Blank Card is First Inserted .....	169
Option DP5705A Behavior When No SD Card is Installed .....	169
Option DP5705A Behavior When SD Card is Used Incorrectly .....	169
SCPI Commands Related to Option DP5705A .....	169
<b>7 Specifications and Characteristics .....</b>	<b>170</b>
Specifications .....	171

<b>Supplemental Characteristics</b> .....	<b>176</b>
<b>Common Characteristics</b> .....	<b>181</b>
<b>Dimension Diagrams</b> .....	<b>183</b>
<b>8 Verification</b> .....	<b>186</b>
<b>Introduction</b> .....	<b>187</b>
<b>Recommended Test Equipment and Setups</b> .....	<b>189</b>
Test Equipment .....	189
Verification Setups .....	190
<b>Performance Verification</b> .....	<b>191</b>
Voltage Programming and Readback Accuracy .....	192
Constant Voltage Load Effect .....	193
Constant Voltage Source Effect .....	193
Constant Voltage Ripple and Noise .....	194
Transient Recovery Time .....	195
Current Programming and Readback Accuracy .....	195
Constant Current Load Effect .....	196
Constant Current Source Effect .....	196
<b>Test Record Forms - 1.5 kW Models</b> .....	<b>198</b>
<b>Test Record Forms - 3.4 kW Models</b> .....	<b>208</b>
<b>Test Record Forms - 5.0 kW Models</b> .....	<b>218</b>
<b>Index</b> .....	<b>232</b>

## Legal and Safety Information

### Legal Notices

### Safety and Regulatory Symbols

### Safety Notices

## Legal Notices

### Copyright Notice

© Copyright Keysight Technologies 2025, 2026

No part of this manual may be reproduced in any form or by any means (including electronic storage and retrieval or translation into a foreign language) without prior agreement and written consent from Keysight Technologies Inc. as governed by United States and international copyright laws.

### Manual Part Number

Manual part number DP5700-90901

### Edition

Edition 2 March 2026

### Published By

Keysight Technologies  
550 Clark Drive, Suite 101  
Budd Lake, New Jersey 07828  
USA

### Warranty

The material contained in this document is provided "as is," and is subject to being changed, without notice, in future editions. Further, to the maximum extent permitted by applicable law, Keysight disclaims all warranties, either express or implied, with regard to this manual and any information contained herein, including but not limited to the implied warranties of merchantability and fitness for a particular purpose. Keysight shall not be liable for errors or for incidental or consequential damages in connection with the furnishing, use, or performance of this document or of any information contained herein. Should Keysight and the user have a separate written agreement with warranty terms covering the material in this document that conflict with these terms, the warranty terms in the separate agreement shall control.

### U.S. Government Rights

The Software is "commercial computer software," as defined by Federal Acquisition Regulation ("FAR") 2.101. Pursuant to FAR 12.212 and 27.405-3 and Department of Defense FAR Supplement ("DFARS") 227.7202, the U.S. government acquires commercial computer software under the same terms by which the software is

customarily provided to the public. Accordingly, Keysight provides the Software to U.S. government customers under its standard commercial license, which is embodied in its End User License Agreement (EULA), a copy of which can be found at <http://www.keysight.com/find/sweula>. The license set forth in the EULA represents the exclusive authority by which the U.S. government may use, modify, distribute, or disclose the Software. The EULA and the license set forth therein, does not require or permit, among other things, that Keysight: (1) Furnish technical information related to commercial computer software or commercial computer software documentation that is not customarily provided to the public; or (2) Relinquish to, or otherwise provide, the government rights in excess of these rights customarily provided to the public to use, modify, reproduce, release, perform, display, or disclose commercial computer software or commercial computer software documentation. No additional government requirements beyond those set forth in the EULA shall apply, except to the extent that those terms, rights, or licenses are explicitly required from all providers of commercial computer software pursuant to the FAR and the DFARS and are set forth specifically in writing elsewhere in the EULA. Keysight shall be under no obligation to update, revise or otherwise modify the Software. With respect to any technical data as defined by FAR 2.101, pursuant to FAR 12.211 and 27.404.2 and DFARS 227.7102, the U.S. government acquires no greater than Limited Rights as defined in FAR 27.401 or DFAR 227.7103-5 (c), as applicable in any technical data

### Declaration of Conformity

Declarations of Conformity for this product and for other Keysight products may be downloaded from the Web. Go to <http://www.keysight.com/go/conformity> and click on “Declarations of Conformity.” You can then search by product number to find the IA Test Declaration of Conformity.

### Waste Electrical and Electronic Equipment (WEEE) Directive 2002/96/EC

This product complies with the WEEE Directive 2002/96/EC marketing requirement. The affixed product label (see below) indicates that you must not discard this electrical/electronic product in domestic household waste.

Product Category: With reference to the equipment types in the WEEE directive Annex 1, this product is classified as “Monitoring and Control instrumentation” product.

Do not dispose in domestic household waste.

To return unwanted products, contact our local Keysight office, or see <http://www.keysight.com/environment/product> for more information.



### Safety and Regulatory Symbols

#### WARNING

A WARNING notice denotes a hazard. It calls attention to an operating procedure, practice, or the like that, if not correctly performed or adhered to, could result in personal injury or DEATH. Do not proceed beyond a WARNING notice until the indicated conditions are fully understood and met.

---

## Legal and Safety Information

### CAUTION

A CAUTION notice denotes a hazard. It calls attention to an operating procedure, practice, or the like that, if not correctly performed or adhered to, could result in damage to the product or loss of important data. Do not proceed beyond a CAUTION notice until the indicated conditions are fully understood and met.

---



Direct current



Alternating current



Frame or chassis terminal



Standby supply. Unit is not completely disconnected from AC mains when switch is off.



Caution, risk of electric shock



Caution, refer to accompanying documents



Protective earth ground terminal



The CE mark is a registered trademark of the European Community.



The TUV mark is a registered trademark of the European community.



The C-tick mark is a registered trademark of the Spectrum Management Agency of Australia. This signifies compliance with the Australian EMC Framework regulations under the terms of the Radio Communications Act of 1992.



Contains one or more of the 6 hazardous substances above the maximum concentration value (MCV), 40 Year EPUP.

ISM1-A

This text indicates that the instrument is an Industrial Scientific and Medical Group 1 Class A product (CISPER 11, Clause 4).

ICES/NMB-001

This text indicates product compliance with the Canadian Interference- Causing Equipment Standard (ICES-001).

## Safety Notices

The following general safety precautions must be observed during all phases of operation of this instrument. Failure to comply with these precautions or with specific warnings or instructions elsewhere in this manual violates safety standards of design, manufacture, and intended use of the instrument. Keysight Technologies assumes no liability for the customer's failure to comply with the requirements.

The equipment is for industrial use. **It is not applicable for IT mains supply systems.** Equipment operators are subject to all applicable safety regulations. Along with the warning and safety notices in this manual, all relevant safety, accident prevention, and environmental regulations must also be followed. In particular, the operators of the equipment:

- Must be informed of the relevant safety requirements.
- Must have read and understood the operating manual before using the equipment.
- Must use the designated and recommended safety equipment.

**WARNING****General**

Do not use this product in any manner not specified by the manufacturer. The protective features of this product may be impaired if it is used in a manner not specified in the operating instructions. Only operate the product at the rated mains voltage and phase as stipulated on the input label.

---

**WARNING****Environmental Conditions**

Never use the instrument outside of the specified environmental conditions described under **Common Characteristics**.

---

**WARNING****Ground the Instrument**

This product is provided with protective earth terminals. To minimize shock hazard, the instrument must be connected to the AC mains through a grounded power cable, with the ground wire firmly connected to an electrical ground (safety ground) at the power outlet. Any interruption of the protective (grounding) conductor or disconnection of the protective earth terminal will cause a potential shock hazard that could result in injury or death.

---

**WARNING****Before Applying Power**

Verify that all safety precautions are taken.

All rear panel connections must be made with the unit turned off, and must be performed by qualified personnel who are aware of the hazards involved. Improper actions can cause fatal injury as well as equipment damage.

Note the instrument's external markings described under "Safety Symbols".

---

**WARNING****HAZARDOUS VOLTAGES**

Many models generate voltages above 60 VDC, with some models rated at up to 1,500 VDC! Ensure that all instrument connections, load wiring, and load connections are insulated or covered so that no accidental contact with lethal voltages can occur.

---

**WARNING**

**SHOCK HAZARD**

Turn off AC power before making rear panel connections.

Ensure that any residual voltages present at the + and – output terminals are discharged before touching the output terminals. Use an independent DVM to measure the voltage between the + and – output terminals, and also from each terminal to ground.

To fully discharge the internal capacitances from the output terminals to ground, momentarily connect a DVM between the + output terminal and ground, and repeat this procedure for the – output terminal. The input resistance of the DVM, often about 10 M $\Omega$  on higher voltage ranges, will discharge the capacitances.

Use a DVM that is rated for the voltages you are measuring or discharging. For higher voltages, especially greater than 1000 V, you may need to use a precision voltage divider between the output terminals and the DVM.

---

**WARNING**

**External Voltage Sources**

Do not connect voltage sources to the output of the power supply with voltage ratings that are greater than the nominal voltage rating of the supply. Under no circumstances can you connect an external voltage with reversed polarity to the output terminal. Equipment damage will result.

---

**WARNING**

**Do Not Operate in an Explosive Atmosphere**

Do not operate the instrument in the presence of flammable gases or fumes.

---

**WARNING**

**Do Not Remove the Instrument Cover**

Only qualified, service-trained personnel who are aware of the hazards involved should remove instrument covers. Always disconnect the power cable and any external circuits before removing the instrument cover.

---

**WARNING**

**Do Not Modify the Instrument**

Do not install substitute parts or perform any unauthorized modification to the product. Return the product to a Keysight Sales and Service Office for service and repair to ensure that safety features are maintained.

---

**WARNING**

**Fuses**

The instrument contains internal fuses, which are not customer accessible.

---

**WARNING**

**Cleaning**

To prevent electric shock, disconnect the AC mains before cleaning. Clean the outside of the instrument with a soft, lint-free, slightly damp cloth. Do not use detergent. Disassembly is not required or recommended for cleaning.

---

**WARNING**

**In Case of Damage**

Instruments that are not functioning correctly, appear damaged or defective should be made inoperative and secured against unintended operation until they can be repaired by qualified service personnel.

---

## Symboles de sécurité

Les consignes de sécurité présentées dans cette section doivent être appliquées au cours des différentes phases d'utilisation de cet appareil. Le non-respect de ces précautions ou des avertissements spécifiques mentionnés dans ce manuel constitue une violation des normes de sécurité établies lors de la conception, de la fabrication et de l'usage normal de l'instrument. Keysight Technologies ne saurait être tenu pour responsable du non-respect de ces consignes.

L'équipement est destiné à un usage industriel. Les opérateurs de l'équipement sont soumis à toutes les règles de sécurité applicables. Parallèlement aux avertissements et aux consignes de sécurité contenues dans ce manuel, toutes les réglementations pertinentes en matière de sécurité, de prévention des accidents et d'environnement doivent également être respectées. En particulier, les opérateurs de l'équipement :

- Doivent être informés des règles de sécurité pertinentes.
- Doivent avoir lu et compris le manuel d'utilisation avant d'utiliser l'équipement.
- Doivent utiliser l'équipement de sécurité désigné et recommandé.

### AVERTISSEMENT

#### Généralités

N'utilisez ce produit que de la manière préconisée par le fabricant. Les fonctions de sécurité de ce produit risquent d'être endommagées si vous ne respectez pas les instructions d'utilisation.

---

### AVERTISSEMENT

#### Conditions environnementales

N'utilisez jamais l'instrument en dehors des conditions environnementales spécifiées décrites dans les Conditions ambiantes des spécifications.

---

### AVERTISSEMENT

#### Poids élevé

Danger pour les mains et les pieds. Pour éviter les blessures et les dommages à l'instrument, utilisez toujours un chariot robuste ou tout autre dispositif approprié pour déplacer l'instrument. Ne soulevez pas l'instrument seul ; soulevez toujours les instruments avec deux personnes.

---

### AVERTISSEMENT

#### RISQUE DE CHOCS Mise à la terre de l'instrument

Ce produit comporte une borne de terre de protection. Afin de réduire les risques d'électrocution, l'instrument doit être relié à une source de courant alternatif par l'intermédiaire d'un cordon d'alimentation secteur pourvu d'un fil de terre connecté fermement à une terre électrique (terre de sécurité) au niveau de la prise de courant. Toute interruption du conducteur de protection (mise à la terre) ou toute déconnexion de la borne de terre de protection vous expose à un risque d'électrocution susceptible de provoquer des blessures ou la mort.

---

**AVERTISSEMENT****Avant la mise sous tension**

Vérifiez que vous avez bien respecté toutes les consignes de sécurité. Toutes les connexions doivent être effectuées lorsque l'appareil éteint et doivent être effectuées par du personnel qualifié qui connaît les dangers inhérents. Toute action incorrecte peut entraîner des blessures mortelles ainsi que des dommages matériels. Lisez les mentions apposées sur l'extérieur de l'instrument décrites à la section « Symboles de sécurité ».

---

**AVERTISSEMENT****RISQUE D'ÉLECTROCUTION, TENSIONS LÉTALES** Certains modèles génèrent des

tensions allant jusqu'à 160 V CC. Assurez-vous que les connexions, les fils de charge et les connexions de charge de l'appareil sont isolés ou couverts de sorte qu'aucun accident par contact ne puisse se produire.

---

**AVERTISSEMENT**

**RISQUE DE CHOCS** Ne touchez jamais les câbles ou les connexions immédiatement après avoir éteint l'appareil. En fonction du modèle, des tensions létales demeurent aux bornes de sortie pendant plusieurs secondes après la mise hors tension. Vérifiez qu'il n'y a pas de tension dangereuse sur les bornes de sortie ou de mesure avant de les toucher.

---

**AVERTISSEMENT****RISQUE DE CHOCS avec les sources d'énergie externes**

Étant donné que l'instrument peut être utilisé comme charge pour courant absorbé, des tensions dangereuses provenant d'une source d'énergie externe telles qu'une batterie peuvent être présentes sur les bornes de sortie même si l'appareil est éteint. Prévoyez de débrancher la source d'énergie externe avant de toucher les bornes de sortie ou de mesure.

---

**AVERTISSEMENT****RISQUE DE CHOCS en cas d'installation ou de retrait de modules**

Ne jamais mettre l'instrument sous tension sans que les six emplacements de modules soient occupés par des modules et/ou des panneaux de remplissage. Ne jamais tenter de retirer ou d'insérer un module ou un panneau de remplissage lorsque l'instrument est sous tension. L'interrupteur d'alimentation doit être éteint et le câble d'alimentation secteur doit être débranchée de l'instrument avant de retirer ou d'installer des modules ou des panneaux de remplissage.

---

**AVERTISSEMENT****Ne pas utiliser en atmosphère explosive**

N'utilisez pas l'instrument en présence de gaz ou de vapeurs inflammables.

---

**AVERTISSEMENT****Ne pas démonter le capot de l'instrument**

Seules des personnes qualifiées, formées à la maintenance et conscientes des risques d'électrocution encourus peuvent démonter les capots de l'instrument. Débranchez toujours le cordon d'alimentation et tous les circuits externes avant de démonter le capot de l'instrument.

---

**AVERTISSEMENT**

**Ne pas modifier l'instrument**

N'installez pas de composants de remplacement et n'apportez aucune modification non autorisée à l'appareil. Pour garantir les caractéristiques de sécurité de l'instrument, retournez-le à votre bureau de vente et d'après-vente Keysight le plus proche en vue d'une opération de maintenance et de réparation.

---

**AVERTISSEMENT**

**Lectures et Etat affiché sur la page de Contrôle Web du Navigateur**

En cas de problèmes de communication réseau, les lectures signalées et l'état de l'instrument affichés dans la page de Contrôle Web du Navigateur peuvent ne pas représenter les lectures ou l'état réel de l'instrument. Ne vous fiez pas aux lectures signalées par le Navigateur de Contrôle Web pour déterminer si un circuit pouvant contenir des tensions dangereuses est mis hors tension en toute sécurité. Ne modifiez jamais les connexions de l'instrument lorsque l'alimentation est appliquée.

---

**AVERTISSEMENT**

**Fusibles**

L'instrument contient un fusible interne non accessible à l'utilisateur.

---

**AVERTISSEMENT**

**Nettoyage**

Pour éviter toute électrocution, débranchez toujours la source de courant alternatif avant le nettoyage. Utilisez un chiffon sec ou légèrement humidifié avec de l'eau pour nettoyer les parties externes. N'utilisez pas de détergent ou de solvant. Ne tentez aucun nettoyage interne.

---

**AVERTISSEMENT**

**En cas de dommages**

Les instruments qui ne fonctionnent pas correctement, endommagés ou défectueux doivent être mis hors fonction et protégés contre toute utilisation involontaire jusqu'à ce qu'ils aient été réparés par un personnel qualifié.

---



# 1

## Quick Reference

### Models and Options

### Introduction to the Instrument

### Front Panel Menu

This chapter concisely describes the Keysight Technologies DP5700 Series System DC Power Supplies.

This chapter is not meant to describe every operating feature in detail. It is simply a quick reference guide to quickly become familiar with the essential components of the power supply. It can also be used as a memory jogger for experienced users to quickly find a front/rear panel function.

A quick reference programming command chart is included at the end of this chapter.

If you find a Keysight product or solution is impacted by a cybersecurity issue, please report it using this link: [Report a Product Cybersecurity Issue | Keysight](#)

## Models and Options

### Model Ratings

1.5 kW Models (half-rack)	Voltage	Current	Power
DP5721A	10 V	150 A	1500 W
DP5722A	20 V	75 A	1500 W
DP5723A	30 V	50 A	1500 W
DP5724A	40 V	38 A	1520 W
DP5726A	60 V	25 A	1500 W
DP5728A	80 V	19 A	1500 W
DP5730A	100 V	15 A	1520 W
DP5731A	150 V	10 A	1500 W
DP5733A	300 V	5 A	1500 W
DP5736A	600 V	2.6 A	1560 W

#### 1.5 kW Models Power Nominal AC Input Range

DP57xxA: 1 phase, 100 - 240 Vac nominal

3.4 kW Models	Voltage	Current	Power
DP5741AS, DP5741AL, DP5741AH	10 V	340 A	3400 W
DP5742AS, DP5742AL, DP5742AH	20 V	170 A	3400 W
DP5743AS, DP5743AL, DP5743AH	30 V	112 A	3360 W
DP5744AS, DP5744AL, DP5744AH	40 V	85 A	3400 W
DP5746AS, DP5746AL, DP5746AH	60 V	56 A	3360 W
DP5748AS, DP5748AL, DP5748AH	80 V	42 A	3360 W
DP5750AS, DP5750AL, DP5750AH	100 V	34 A	3400 W
DP5751AS, DP5751AL, DP5751AH	150 V	22.5 A	3375 W
DP5753AS, DP5753AL, DP5753AH	300 V	11.5 A	3450 W
DP5756AS, DP5756AL, DP5756AH	600 V	5.6 A	3360 W

#### 3.4 kW Models Power Nominal AC Input Range

DP57xxAS: 1 phase, 200 - 240 Vac nominal

DP57xxAL: 3 phase, 200 - 240 Vac nominal line-to-line

DP57xxAH: 3 phase, 380 - 480 Vac nominal line-to-line

5 kW Models	Voltage	Current	Power
DP5761AL, DP5761AH	10 V	500 A	5000 W
DP5762AL, DP5762AH	20 V	250 A	5000 W
DP5763AL, DP5763AH	30 V	170 A	5100 W
DP5764AL, DP5764AH	40 V	125 A	5000 W
DP5765AL, DP5765AH	50 V	100 A	5000 W
DP5766AL, DP5766AH	60 V	85 A	5100 W
DP5768AL, DP5768AH	80 V	65 A	5200 W
DP5770AL, DP5770AH	100 V	50 A	5000 W
DP5771AL, DP5771AH	150 V	34 A	5100 W
DP5772AL, DP5772AH	200 V	25 A	5000 W
DP5773AL, DP5773AH	300 V	17 A	5100 W
DP5774AL, DP5774AH	400 V	13 A	5200 W
DP5775AL, DP5775AH	500 V	10 A	5000 W
DP5776AL, DP5776AH	600 V	8.5 A	5100 W

#### 5 kW Models Power Nominal AC Input Range

DP57xxAL: 3 phase, 200 - 240 Vac nominal line-to-line  
 DP57xxAH: 3 phase, 380 - 480 Vac nominal line-to-line

## Accessories/Options

Accessory/Option Number	Description
DP5701A	Half Rack Mount Kit for 1.5 kW models
N5740A	Full Rack Mount Kit for 3.4 kW, 5 kW models
DP5705A	Removeable SD Memory option
DP5706A*	Auto Parallel Cable

\*This cable is intended to be used only for DP5700 series products.  
 Auto-paralleling via DP5706A is supported only for models with output ratings of 3.4 kW, 5.0 kW.

## Introduction to the Instrument

### Front Panel at a Glance

### Front Panel Display at a Glance

### Rear Panel at a Glance

The Keysight Technologies DP5700 Series System DC Power Supplies are general-purpose, 1U (rack unit) high, switching power supplies that are available with a wide variety of output voltage and current ratings. Refer to the **Models and Options** section for a description of the output ratings of the various models.

Output voltage and current are continuously displayed and the display can also show the operating status of the power supply.

The front panel controls allow the user to set the output parameters, over-voltage, under-voltage, and over-current protection levels, and preview the settings. An extensive front panel menu provides additional power supply functions including communication, protection, external control and triggering

The rear panel includes the necessary connectors to control and monitor the power supply operation by analog signals or by the built-in remote communication interfaces.

### Output features

- Constant voltage/constant current with automatic crossover
- High-resolution voltage and current front panel controls
- Accurate voltage and current readback
- Remote sensing to compensate for voltage drop in load leads
- Output voltage and current list capability
- Analog output programming and monitoring
- Paralleling capability for increased output power
- Independent level-triggered external enable/disable
- Protection capability includes over-voltage, over-current, over-temperature, and other protections

### System features

- GPIB (IEEE-488), LAN, and USB remote programming interfaces
- A built-in Web server that lets you control the instrument directly from an internet browser
- Front panel menu setup for LAN and GPIB

- Save and recall up to 10 instrument states in non-volatile memory
- SCPI (Standard Commands for Programmable Instruments) compatibility

## Programmable functions

- Voltage, current, and power settings
- Voltage, current, and power measurements
- Output list trigger control
- Output voltage and current protections
- Status register control and query

## Front Panel at a Glance

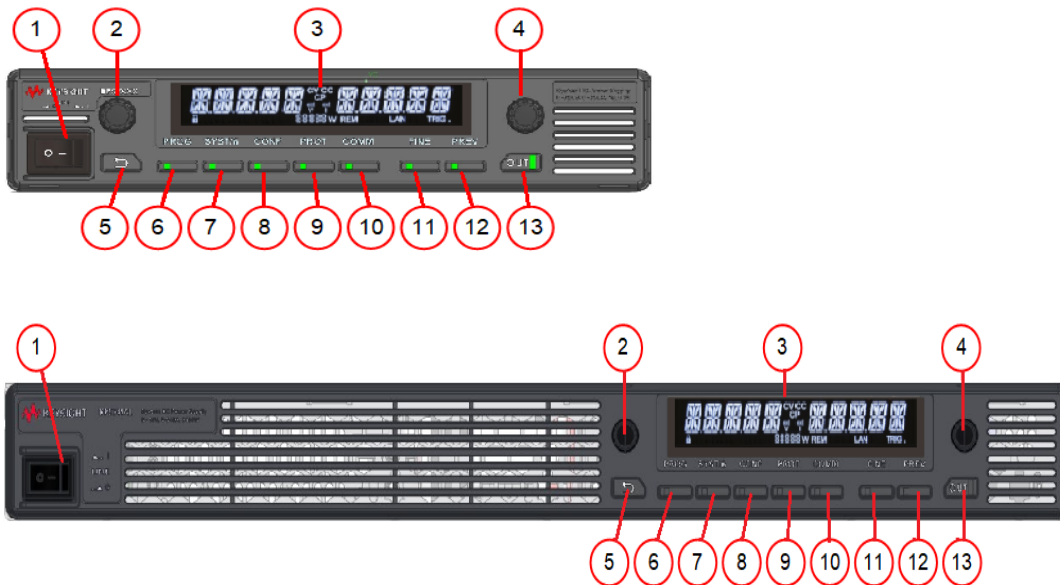

<b>1 - Power switch</b>	Turns the power supply on or off.
<b>2 - Voltage knob</b>	<u>When rotated:</u> Adjusts the output voltage and navigates the menu. <u>When pushed:</u> Accepts the voltage setting in Preview mode.
<b>3 - Display</b>	LED display. Refer to following section for a detailed description.
<b>4 - Current knob</b>	<u>When rotated:</u> Adjusts the output current and navigates the menu. <u>When pushed:</u> Accepts the current setting in Preview mode, selects a menu item, and sets a parameter value.
<b>5 - BACK key</b>	Backs up one level in the front panel menu.
<b>6 - PROG key</b>	Activates the Program menu. The LED lights when the menu is active. The Program menu configures the trigger functions. Press the PROG key again to exit the menu.

---

<b>7 - SYST key</b>	Activates the System menu. The LED lights when the menu is active. System functions include: Local Remote sense selection, Interlock control, Output enable control, SAVE/RECALL state configuration, Programmable Signal control, Preload state control, Display brightness control, and Reset settings. Press the PROG key again to exit the menu.
<b>8 - CONF key</b>	Activates the Configuration menu. The LED lights when the menu is active. Configuration functions include: Power on control, Voltage & Current source control, Analog Programming/Monitoring range selection, Internal Resistance control, Constant power limit control, and Slew-rate control. Press the CONF button again to exit the system menu.
<b>9 - PROT key</b>	Activates the Protection menu. The LED lights when the menu is active. Protection functions include: OVP control, OCP control, UVP control, OCL control, ON/OFF control, and Protection clear. Press the PROT key again to exit the menu.
<b>10 - COMM key</b>	Activates the Communication menu. The LED lights when the menu is active. Communication functions include: LAN settings control, viewing GPIB address, and viewing software revision. Press the COMM key again to exit the menu.
<b>11 - FINE key</b>	Selects fine or course knob control. The LED lights when the Fine control is active. In Fine mode, Voltage and Current knobs operate in high-resolution mode. In Coarse mode, Voltage and Current knobs operate in standard resolution (about three turns for zero to full scale). Press the FINE key to toggle between fine or coarse.
<b>12 - PREV key</b>	Display the output voltage and current Limit settings. The LED lights when Preview mode is active. The display shows the preview settings for 5 seconds and then returns to show the actual output voltage and current. You can change the preview settings while the Preview mode is active. Then, after 15 seconds, the display returns to show actual output voltage and current. Press the PREV key again to exit Preview mode.
<b>13 - OUT key</b>	Turns the power supply output on or off. The green LED lights when the output is ON. Press the OUT button again to turn the output off. If the LED blinks RED, an alarm or protection event has occurred. and the output is turned off. Refer to <b>Enable Output</b> for additional information.

---

## Front Panel Display at a Glance

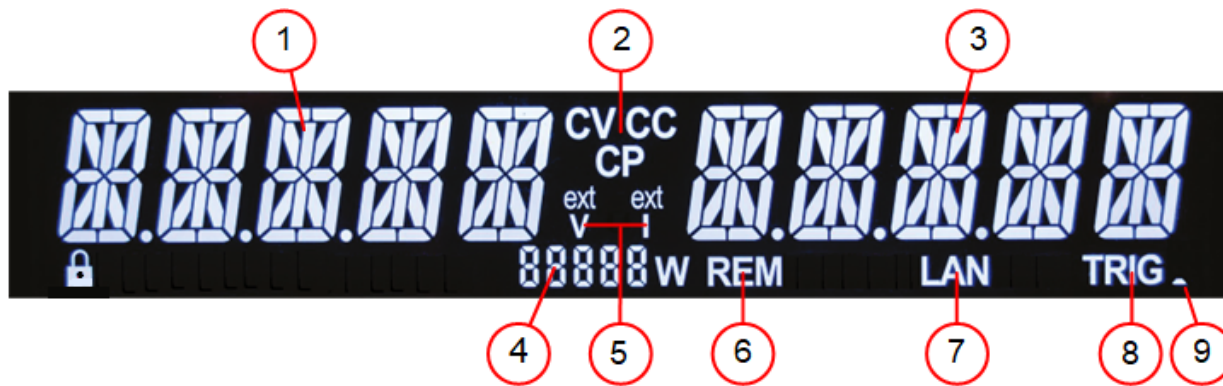

1 - Displays the output voltage and the voltage setting in Preview mode. Also indicates the selected function in navigation mode.

2 - Indicates constant voltage, constant current, or constant power operation.

3 - Displays the output current and the current setting in Preview mode. Also indicates the selected parameter in navigation mode.

4 - Indicates output power in watts.

5 - Indicates either external V or external I input is active.

6 - Indicates remote voltage sensing is in use.

7 - Indicates LAN is connected and has acquired an IP address.

8 - Indicates that the power supply is ready to receive a trigger signal.

9 - Indicates IO activity when blinking.

## Rear Panel at a Glance

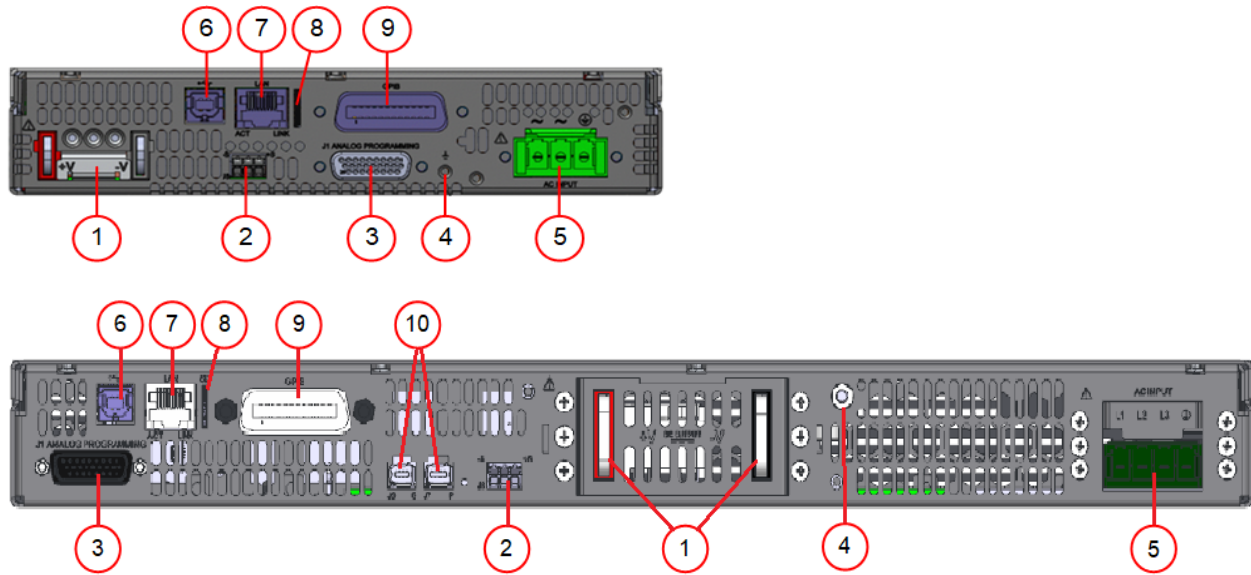

<b>1 - DC Output</b>	Connector type for 1.5 kW, 3.4 kW, 5 kW: For 10 V to 100 V models: bus bars For 150 V to 600 V models: GIC 2.5/ 4-G-7,62 PHOENIX CONTACT (half rack) IPC 5/ 4-GF-7,62 PHOENIX CONTACT (full rack)
<b>2 - Remote Sense</b>	Remote sense connector type: For 1.5 kW, 3.4 kW, 5 kW: SPT-THR 1, 5/ 3-H-3, 5 P26 PHOENIX CONTACT
<b>3 - J1 Analog Programming</b>	Connector for isolated analog control and monitoring signals DB26HD type female, isolated from the output potential
<b>4 - Ground</b>	Earth ground terminal: M3x8 Sems screw (Half-Rack); 10-32x8 Stud (Full-Rack)
<b>5 - AC Input</b>	Connector type: 1.5 kW and 3.4 kW 1-Phase: PC 5/ 3-G-7,62 PHOENIX CONTACT 3.4 kW and 5 kW 3-Phase: PC 5/ 4-G-7,62 PHOENIX CONTACT
<b>6 - USB</b>	USB interface connector, type B
<b>7 - LAN</b>	LAN interface connector, with indicators ACT (green) indicates activity when on LINK (amber) indicates 100 Mbps speed when on; 10 Mbps speed when off
<b>8 - SD Slot</b>	SD card slot (for option DP5705A)
<b>9 - GPIB</b>	External control signal connector
<b>10 - Paralleling</b>	Parallel connectors for Primary/Secondary operation, mini I/O type

## J1 Connector Pin Functions

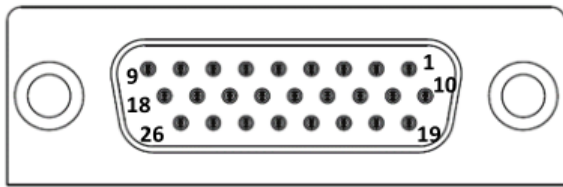

**CAUTION Equipment Damage** The common (COM) pins are internally connected to the USB and GPIB grounds. Only connect these pins to external circuitry that is either at earth ground potential or, to avoid ground loops, float the connections.

Pin Number and Name	Signal Description
1 - Shut Off	Edge-triggered input for shut off.
2 - PS_OK #2	Output #2 for indication of power supply status. Normally high, goes low for fault.
3 - PS_OK #1	Output #1 status. Open-collector type, high for fault or output off.
4 - CV/CC	Output for Constant-Voltage/Constant-Current indication.
5 - Analog Indicator	Output indicates voltage and/or current are analog programmed.
6 - Analog select	Input for selecting analog programming of voltage and/or current.
7 - IPGM	Input for analog voltage/resistance programming of output current.
8 - VPGM	Input for analog voltage/resistance programming of output voltage.
9 - not used	
10 - ENA_IN	Enables/disables the output by dry-contact (short/open) or voltage source. Selectable signal polarity.
11 to 14 - COM	Common return for all signals. Connected to USB and GPIB grounds.
15 to 16 - not used	
17 to 18 - COM	Common return for all signals. Connected to USB and GPIB grounds.
19 - ILC	Interlock enables/disables the output by dry-contact interlock signal or voltage source.
20 - Prog_out_2	General purpose programming port 2 (open drain).
21 - Prog_out_1	General purpose programming port 1 (open drain).
22 - Trigger In	Trigger input for list sequencer. Positive edge triggered, pulse width: 10 $\mu$ s min.
23 - Trigger Out	Trigger output, positive edge, pulse width: 100 $\mu$ s min.
24 - not used	
25 - I_MON	Output for monitoring the output current.
26 - V_MON	Output for monitoring the output voltage.

Refer to for [External Control Signal Programming](#) for details.

## Front Panel Menu

This is an overview of the front-panel menus. For a brief tutorial, refer to [Turn-On Checkout](#).

Press a front panel key to access the corresponding menu. The green LED lights when the menu is active. Press the front panel key again to exit the menu.

Use the Voltage knob on the left side to navigate the vertical menu selections.

Use the Current knob on the to navigate the horizontal menu selections.

**NOTE**

When a menu is activated with no additional key pressed within 15 seconds, the power supply returns to displaying the actual output voltage and current.

1st Level	2nd Level	3rd & 4th Levels	Description
<b>PROG</b> key	TRG.OU	OFF   FSTR   TRG	Selects the operating mode of the trigger out signal: OFF turns the trigger signal off TRIG generates a trigger signal if the output state changes FSTR generates a signal when the output state, voltage, or current changes
<b>SYST</b> key	SENSE	LOCAL   REM	Selects local or remote voltage sensing
	ILC	OFF   ON	Turns the Interlock function on or off
	ENA	OFF   ON	Turns the power supply output Enable on or off
	ENA.PL	REV.   NORM	Selects the polarity of the output Enable signal. (normal or reversed)
	SAVE	<state>	Saves the present output state to a location numbered 0 through 9
	RECAL	<state>	Recalls a saved output state from a location numbered 0 through 9
	PIN 1	OFF   ON	Turns the auxiliary programming signal on pin 1 on or off
	PIN 2	OFF   ON	Turns the auxiliary programming signal on pin 2 on or off
	PREL	OFF   ON	Turns the preload state on or off
	DISP	BRT   DM.BRT   DM.DL	Configures the front panel brightness
		BRT	Selects a brightness value from 1 to 4
		DM.BRT	Selects a dimming value from 0 to 3, or turns dimming off
		DM.DL	Selects a dimming delay, either 15, 30, or 60 seconds <b>NOTE:</b> This selection only appears when dimming is on
<b>CONF</b> key	V.SRC	PANEL   E.VOL   E.RES	Selects the output voltage source control: PANEL programs the voltage from the front panel E.VOL programs the voltage using an external voltage source E.RES programs the voltage using an external resistance
	C.SRC	PANEL   E.VOL   E.RES	Selects the output current source control: PANEL programs the current from the front panel E.VOL programs the current using an external voltage source E.RES programs the current using an external resistance
	RANGE	5   10	Selects the analog monitoring and programming range (5 V or 10 V)

1st Level	2nd Level	3rd & 4th Levels	Description
	PWR.ON	*RST   RCL 0	Selects the power-on state, either the Reset or Recall 0 state
	R.INT	OFF   ON	Turns the internal resistance function on or off
	RES	<value>	Enters a resistance value from 0.001 to 1.000 ohms <b>NOTE:</b> This selection only appears when R.INT is on
	C.PWR	OFF   ON	Turns the constant power function on or off
	POWER	<value>	Enters a constant power value from Min to Max (model dependent) <b>NOTE:</b> This selection only appears when R.INT is on
	SLEW	OFF   CURR   VOLT	Selects the current or voltage slew rate: OFF turns the slew function off CURR selects the current slew control VOLT selects the voltage slew control
	CSL.UP	<value>	Enters an up-programming current slew from 0.0001 to 999.99 A/ms <b>NOTE:</b> This selection only appears when CURR slew is on
	CSL.DN	<value>	Enters a down-programming current slew from 0.0001 to 999.99 A/ms <b>NOTE:</b> This selection only appears when CURR slew is on
	VSL.UP	<value>	Enters an up-programming voltage slew from 0.0001 to 999.99 V/ms <b>NOTE:</b> This selection only appears when VOLT slew is on
	VSL.DN	<value>	Enters a down-programming voltage slew from 0.0001 to 999.99 V/ms <b>NOTE:</b> This selection only appears when VOLT slew is on
<b>PROT</b> key	OVP	<value>	Enters an overvoltage protection value from Min to Max (model dependent)
	UVP.LV	<value>	Enters an under-voltage protection level from 0 to Max (model dependent)
	UVP.EN	OFF   ON	Turns the UVP function on or off
	UVP.DL	<value>	Enters a UVP delay value from 0.1 to 25.5 seconds <b>NOTE:</b> This selection only appears when UVP is on
	OCP	OFF   ON	Turns the over-current protection function on or off
	OCP.DL	<value>	Enters an OCP delay value from 0.1 to 25.5 seconds <b>NOTE:</b> This selection only appears when OCP is on
	OCL	OFF   ON	Turns the analog programming over-current protection function on or off
	PROT	CLEAR	Clears all protection functions
		SURE	Confirms the protection clear NO   YES
<b>COMM</b> key			Configures the LAN and GPIB <b>NOTE:</b> The IP4, IP6.LL, IP6.GL, MAC, and LAN RESET selections only appear when the LAN interface is active
	IP4	<address>	Configures the IP4 address from 1 to 4
		IP4.1	Enter a value from 0 to 255
			; scroll down
		IP4.4	Enter a value from 0 to 255
	IP6.LL	<address>	Configures the IP6.LL address from 1 to 6
		IP6.1	Enter a value from 0000 to FFFF

## 1 Quick Reference

1st Level	2nd Level	3rd & 4th Levels	Description
			; scroll down
		IP6.6	Enter a value from 0000 to FFFF
	IP6.GL	<address>	Configures the IP6.GL address from 1 to 8
		IP6.1	Enter a value from 0000 to FFFF
			; scroll down
		IP6.8	Enter a value from 0000 to FFFF
	MAC	<address>	Displays the MAC address from 1 to 6
		MAC1	Displays a value from 00 to FF
			; scroll down
		MAC6	Displays a value from 00 to FF
	LAN	RESET	Resets the LAN
		SURE	Confirms the LAN reset NO   YES
	GPIB	<address>	Configures the GPIB address from 0 to 30
	REV.	<revision>	Displays the power supply's firmware revision

# 2

## Installing the Instrument

### **Before Installation or Use**

#### **Rack Mounting**

#### **AC Mains Connections**

#### **Single Unit Connections**

#### **Multiple Unit Connections**

#### **External Control Signal Connections (Analog)**

This chapter describes how to install your power supply. It discusses installation, rack mounting, and line cord connections.

This chapter also discusses how to connect your load to the output terminals. It discusses what you need to know about wire sizes and how to compensate for voltage drops in the load leads. It also discusses various loads configurations and how to connect units in series and parallel.

Before getting started, check the list under “Items Supplied” and verify that you have received these items with your instrument.

### Before Installation or Use

#### **Inspect the Unit**

When you receive your power supply, inspect it for any obvious damage that may have occurred during shipment. If there is damage, notify the shipping carrier and nearest Keysight Sales and Support Office immediately. Refer to [www.keysight.com/find/assist](http://www.keysight.com/find/assist).

Until you have checked out the power supply, save the shipping carton and packing materials in case the unit has to be returned. Check the list below and verify that you have received these items with your unit. If anything is missing, please contact your nearest Keysight Sales and Support Office. Use [www.keysight.com/find/assist](http://www.keysight.com/find/assist) for information on contacting Keysight worldwide.

## Check for Items Supplied

Before getting started, check the following list and verify that you have received these items with your unit. If anything is missing, please contact your nearest Keysight Sales and Support Office.

### Items Supplied for 1.5 kW Units

Item	Description
Documents	Manual, Cal Certificate, Packing List
Feet	For Desk Top Use
Push Rivets	For the Feet Attachment
SEMS Screw M3X8	For AC Input Cover Mounting
AC Input Plug	Phoenix Contact p/n PC5/ 3-STCL1-7, 62
Strain Relief Bracket Assy	Sheet Metal Cover/Bracket for AC -Input
Strain Relief	LAPP Group p/n 5301 5420
Lock Nut	Agro p/n 8211
DB-26 Connector	FCI p/n 1009070769-P264ALF
DB-15 Blackshell	FCI p/n 86303638BLF
Output Cover <sup>1</sup>	Plastic Cover
SEMS Screw M3X40 <sup>1</sup>	Used for Mounting Output Cover
Flat Washer M3 <sup>1</sup>	Used for Mounting Output Cover
Hex Screw M6X16 <sup>1</sup>	For Output Connection
Hex Nut M6 <sup>1</sup>	For Output Connection
Flat Washer <sup>1</sup>	For Output Connection
Spring Washer <sup>1</sup>	For Output Connection
Output Connector <sup>2</sup>	Phoenix Contact p/n PC5/ 4-STF-7, 62
Output Terminal Clips <sup>2</sup>	(See <a href="#">Single Load Connections</a> )
Ferrite Core	(See <a href="#">Ferrite Core Installation</a> )

1 Only used in 10 V to 100 V Models DP5721A, DP5722A, DP5723A, DP5724A, DP5726A, DP5728A, & DP5730A

2 Only used in 150 V to 600 V Models DP5731A, DP5733A, & DP5736A

## 2 Installing the Instrument

### Items Supplied for 3.4 kW and 5 kW Units

Item	Description
Right Handle Bracket	L shaped Bracket for rack mounting Right Side
Left Handle Bracket	L shaped Bracket for rack mounting Left Side
Handles	1U Handles that mount to Bracket
Flat Head M3X8 screws	Mounting Bracket to chassis
Flat Head 10-32 x 3/8 screws	Mounting Handles to Bracket
Strain Relief Bracket Assy	Sheet Metal Cover/Bracket for AC - Input
SEMS screw M3X8	For AC In Cover Mounting
AC Input Plug	Phoenix Contact p/n PC 5/ 3-STCL1-7,62
Strain Relief	LAPP Group p/n 5301 5440
Lock Nut	Agro p/n 8216
DB - 26 Connector	FCI p/n 1009070769-P264ALF
DB - 15 Backshell	FCI p/n 86303638BLF
Output Cover Assy	Sheet Metal Cover Assembly for the Output
SEMS Screw M3X6	For Mounting the Output Cover to Chassis
Hardware <sup>1</sup>	Nuts, Bolts, and Washers for Mounting Output Cables to Bus Bars
Certificate of Calibration	Calibration certificate referenced to serial number
Terminal Plugs <sup>2</sup>	Output Terminal Plugs

1 Only used in DP5741AS - DP5750AS, DP5741AL - DP5750AL, DP5741AH - DP5750AH, DP5761AL - DP5770AL, DP5761AH - DP5770AH

2 Only used in DP5751AS - DP5756AS, DP5751AH - DP5756AH, DP5751AL - DP5756AL, DP5771AH - DP576AH, DP5771AL - DP5776AL

## Review Safety Information

This power supply is a Safety Class 1 instrument, which means it has a protective earth terminal. That terminal must be connected to earth ground through a power source equipped with an earth ground. Refer to the **Safety Notices** section at the beginning of this guide for general safety information. Before installation or operation, check the power supply and review this guide for safety warnings and instructions. Safety warnings for specific procedures are located at appropriate places throughout this guide.

## Observe Environmental Conditions

**WARNING** Do not operate the instrument in the presence of flammable gases or fumes.

---

The environmental conditions of the power supply are documented under **Specifications**. Basically, the unit should only be operated indoors in a controlled environment. Do not operate the unit in areas where the ambient temperature exceeds +45 degrees Celsius. This applies for rack-mounting as well as for bench use.

## Provide Adequate Air Flow

**CAUTION** Do not block the air intake at the front, or the exhaust at the rear of the unit.

---

The dimensions of your power supply along with an outline diagram are given under **Dimension Diagrams**. Fans cool the power supply by drawing air through the front grill and exhausting it out the back. Allows at least 8 inches (20 cm) of space at the front and back of the unit for adequate air circulation.

## Desk Top Use

To prevent slipping when using on a desk top surface, install feet onto bottom side of the unit. Use the Plastic Rivets to hold the rubber feet in place on the bottom surface by inserting them into the four equally spaced holes. If the unit's use is switched to Rack Mounting, the feet must be removed for proper Rack Mounting.

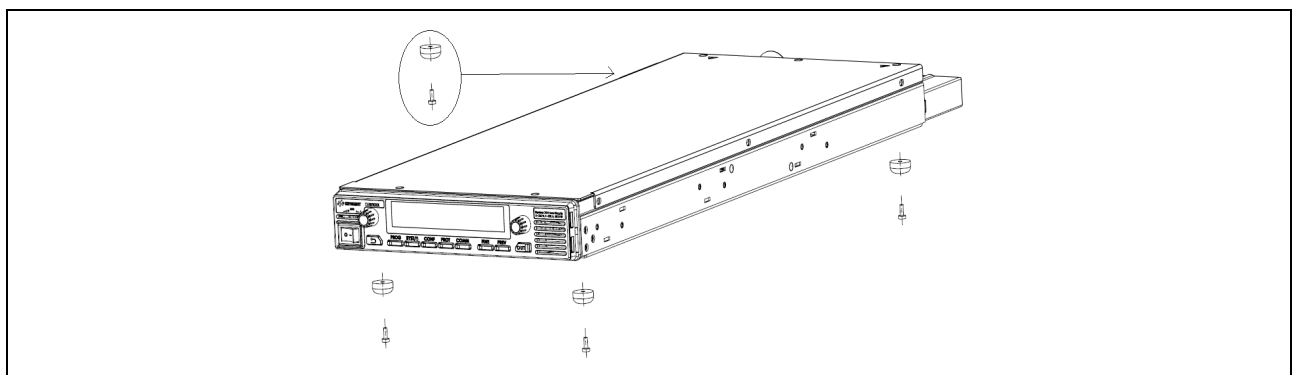

## Rack Mounting

### Rack Mounting a Single 1.5 kW Unit

### Rack Mounting Dual 1.5 kW Units

### Rack Mounting 3.4 kW and 5 kW Units

This section contains information for installing a DP5701A Rack Mount Kit. This rack mount kit allows the units to be mounted in a 19-inch EIA rack cabinet.

Item	Items Supplied	Quantity
1	Right and left front corners	2
2	Blank panel for single-unit installation	1
3	Connection bracket for dual-unit installation	1
4	Right and left rear movable brackets	2
5	Handles	2
6	Flat head screw M3X6	6
7	Flat head screw M3X8, for right corner bracket on single units, and both corner brackets on dual units	6
8	Flat head screw M3X10, for left corner bracket on single unit	3
9	Flat head screw 10-32 x 3/8, for both handles	4
10	SEMS screw M3X8, for two movable brackets and ground screw on dual units	5
11	HEX. Nut M3. for left corner bracket	3
12	Flat washer M3. for left corner bracket	3
13	Spring washer M3. for left corner bracket	3

**NOTE** If previously installed remove feet from the unit(s)

---

**NOTE** This Rack Kit has been designed for use with Keysight 19 Inch Racks. It may also work with similar designed 19 Inch racks.

---

**Tools Needed** Phillips P1 and P2 drivers, 5.5 nut driver.

---

**NOTE** Prior to installing the rack mount kit, you will need to:

---

1. Install up to eight clip-nuts on the rack frame where your instrument will be located. Install two on each front corner; and two on each rear corner (if both rear corners are used).
2. Assemble the rack mount kit as described in the following sections.
3. When complete, slide the rack mount assembly into the cabinet and fasten the front and rear corners with the front dress screws and rear rack screws provided with your cabinet.

**NOTE** All M3 screws tightening torque is 4.7–5.7 lb-in (0.53–0.64 Nm). P1 driver.  
All 10-32 screws (for handles) tightening torque is 12.5–13.5 lb-in (1.41–1.52 Nm). P2 driver.

---

## Rack Mounting a Single 1.5 kW Unit

**NOTE** Remove feet if installed prior to rack mounting.

---

The following figure shows the location of the four feet that must be removed before rack mounting.

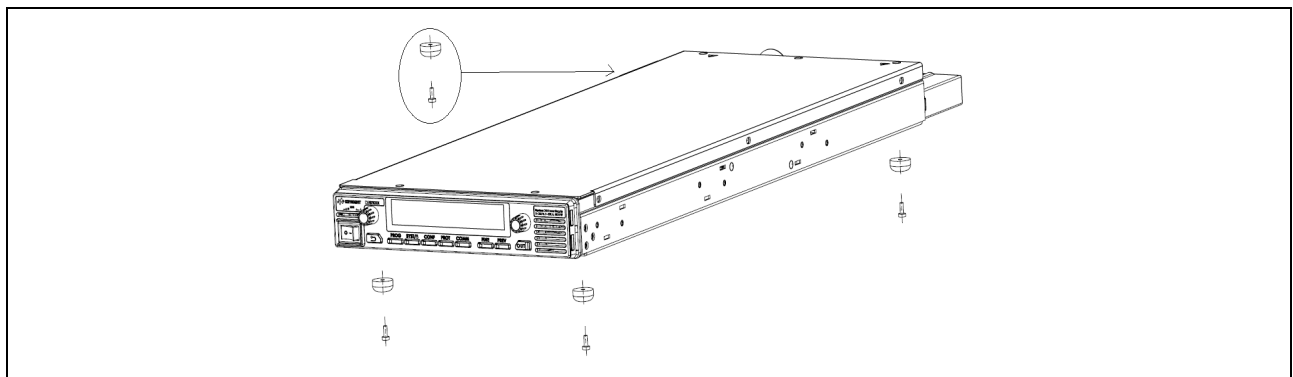

## 2 Installing the Instrument

The following figure shows the assembled rack mount components for single units. The unit can be mounted either on the left or the right side of the cabinet. The following procedure installs the unit on the right side.

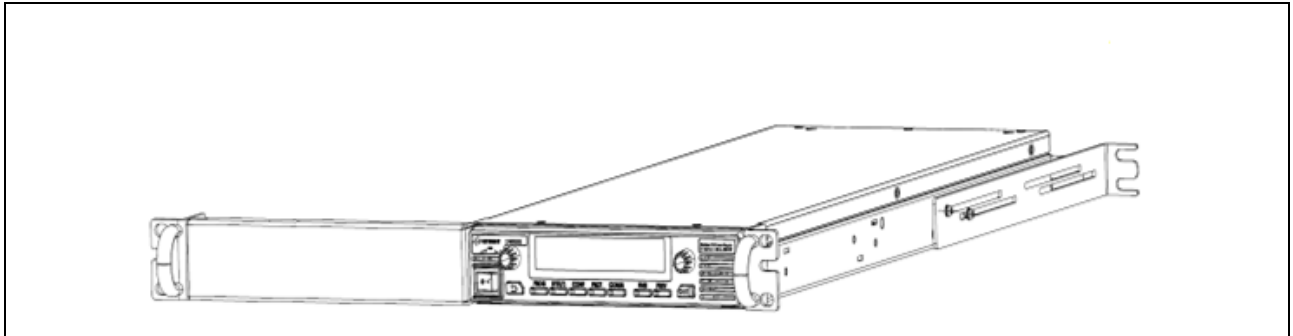

Assemble the stationary part of the rack mount kit (left side).

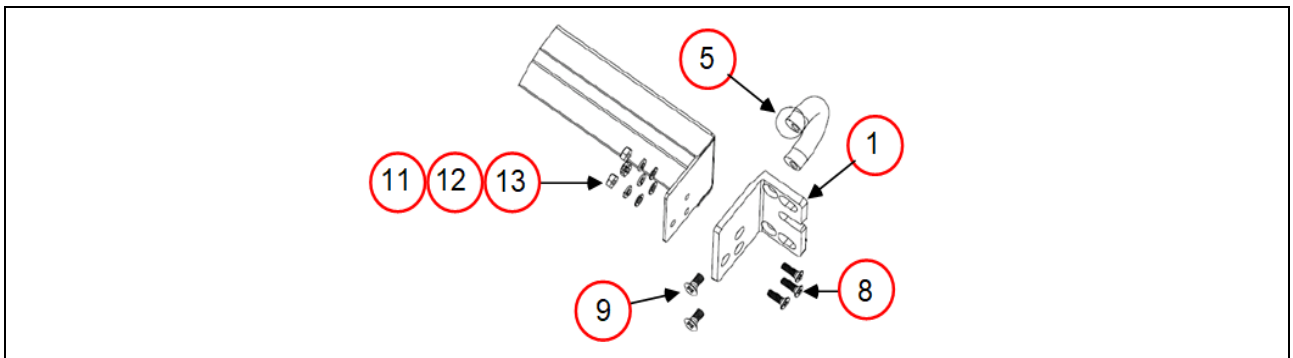

1. Attach the left front corner (1) to the blank panel using the three screws (8) and hardware (11, 12, 13) in the following order: Flat head screw M3X10, Flat washer M3X10, Spring washer M3X10, and Nut M3
2. Attach the handle (5) to the corner bracket using two supplied screws (9): Flat head screw 10-32 x 3/8. The threaded hole in the handle should be oriented toward the outside of the rack assembly to allow enough room for the front panel dress screws.

Attach the blank panel of the rack mount kit to the left side of the unit.

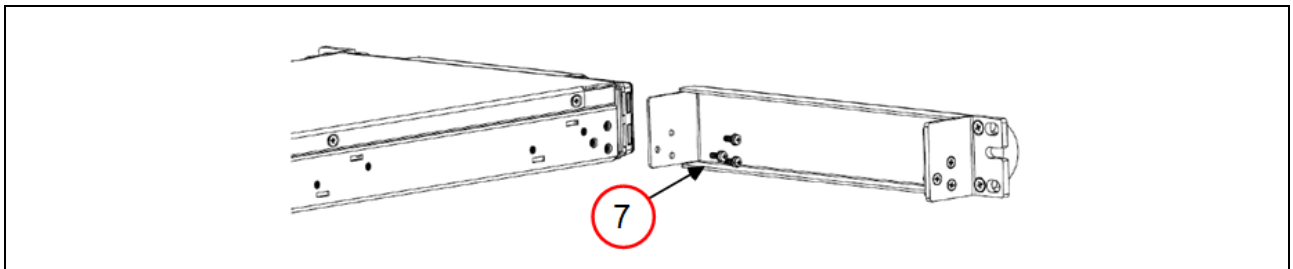

1. Attach the blank panel using the three screws (7): SMS screw M3X8

Attach the movable part of the rack mount kit to the right side of the unit.

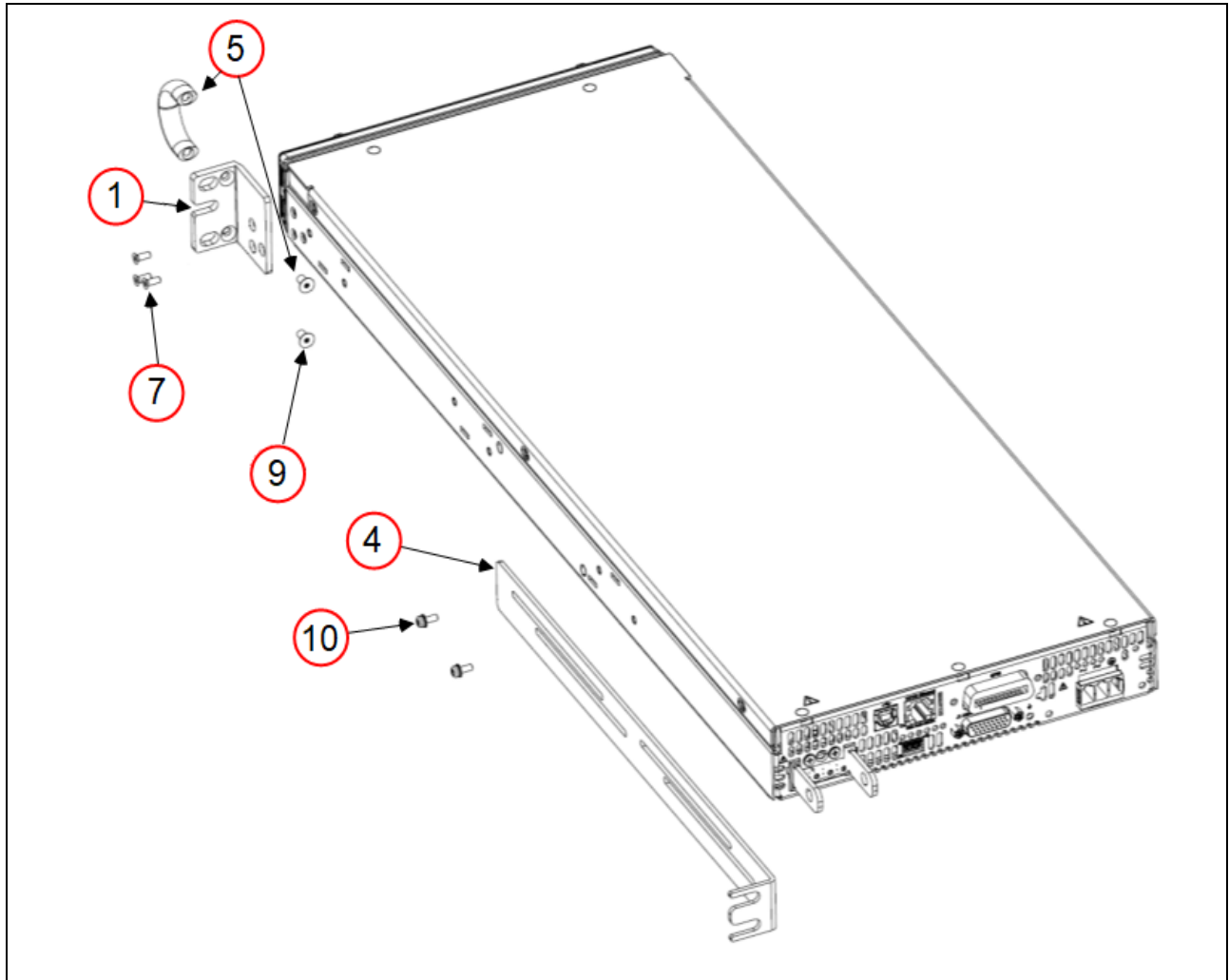

1. Attach the right corner(1) to the right side using three screws (7): Flat head screw M3X8.
2. Attach the handle (5) to the right corner bracket using two screws (9): Flat head screw 10-32 x 3/8. The threaded hole in the handle should be oriented toward the outside of the rack assembly to allow enough room for the front panel dress screws.
3. Attach the movable bracket (4) to the right side using the two screws (10): Flat head screw M3X8. Adjust the movable bracket to fit the depth of the cabinet.

### Rack Mounting Dual 1.5 kW Units

The following figure shows the assembled rack mount components for dual units. Before you begin, place the two units side-by-side on a flat surface.

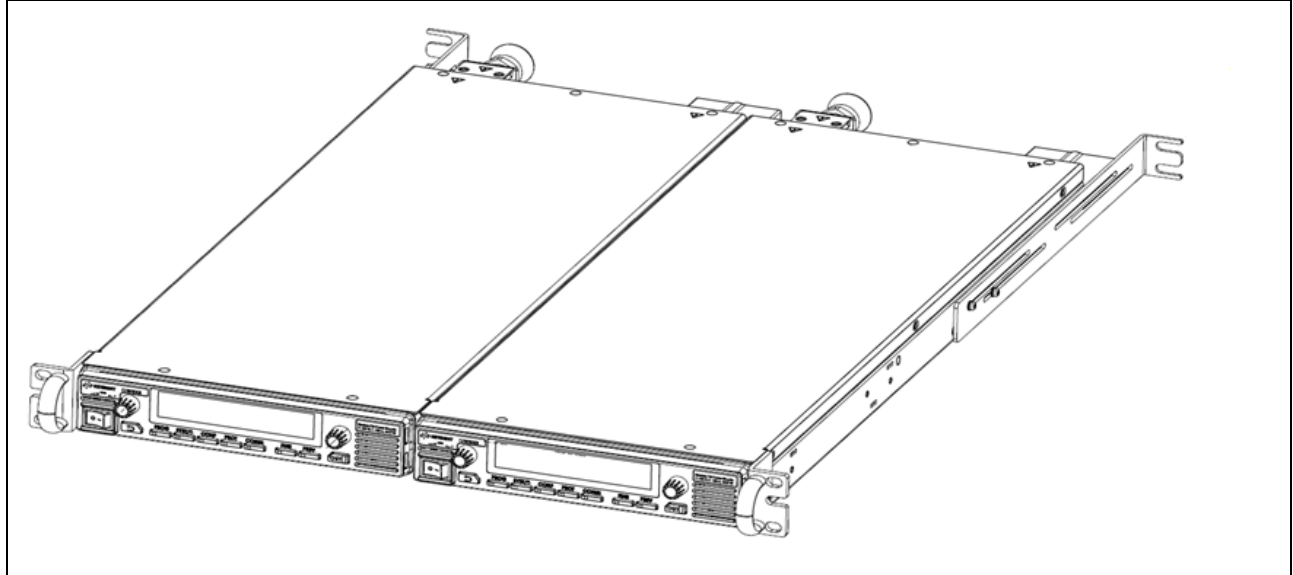

Attach the connection bracket to the rectangular holes on the right side of the first dual unit. This unit will be located to the left side of the dual assembly when viewed from the front.

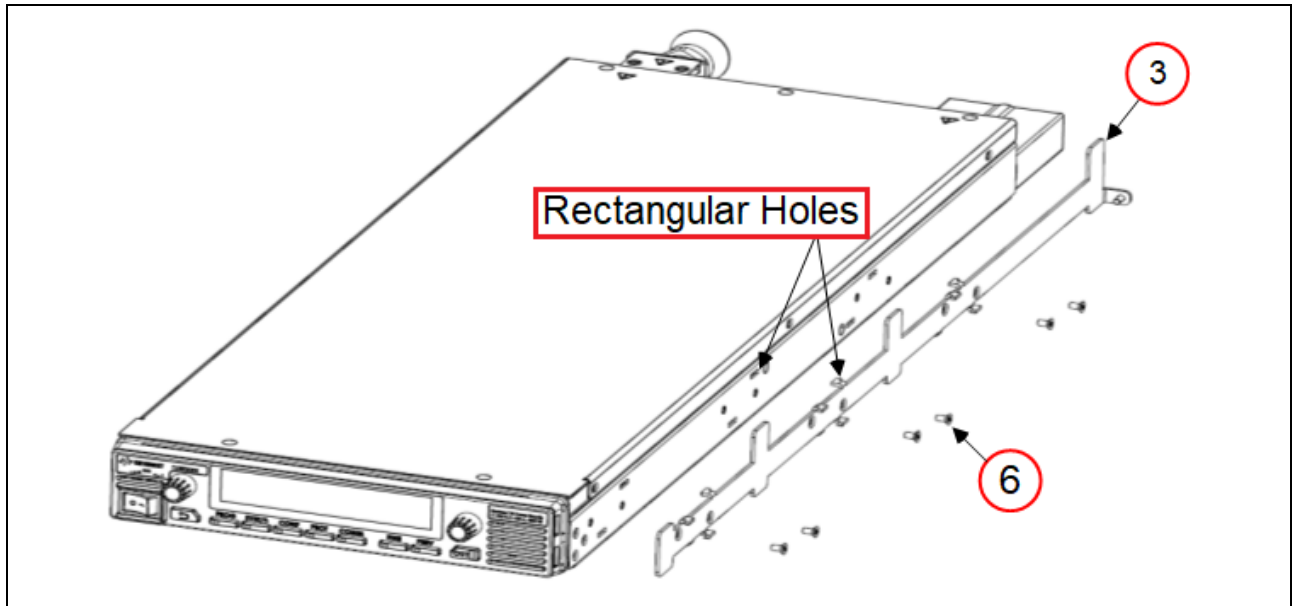

1. Insert the connection bracket (3) in the six rectangular holes on the right side of the first dual unit. Slide the connection bracket forward.
2. Attach the six screws (6) to the connection bracket: Flat head screw M3X6

Attach the connection bracket to the rectangular holes on the left side of the second dual unit.

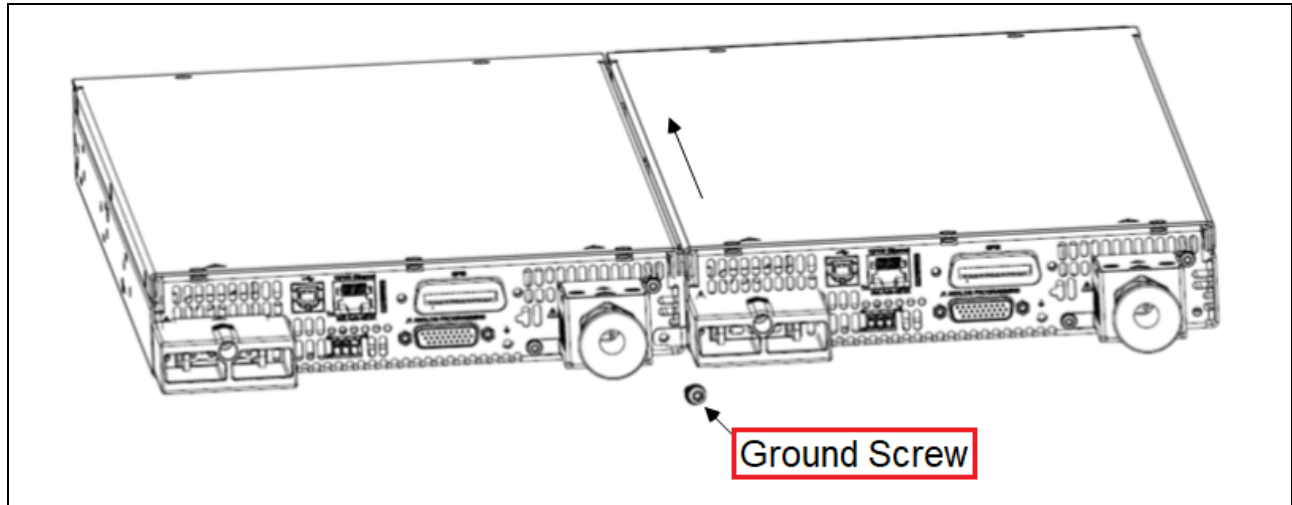

1. First remove the ground screw from the back of the second dual unit.
2. Attach the connection bracket to the rectangular holes on the left side of the second dual unit. Then slide the first dual unit forward.
3. Reinstall the ground screw on the back of the second dual unit to lock the connection bracket in place.

Attach the movable part of the rack mount kit to the right side of the unit.

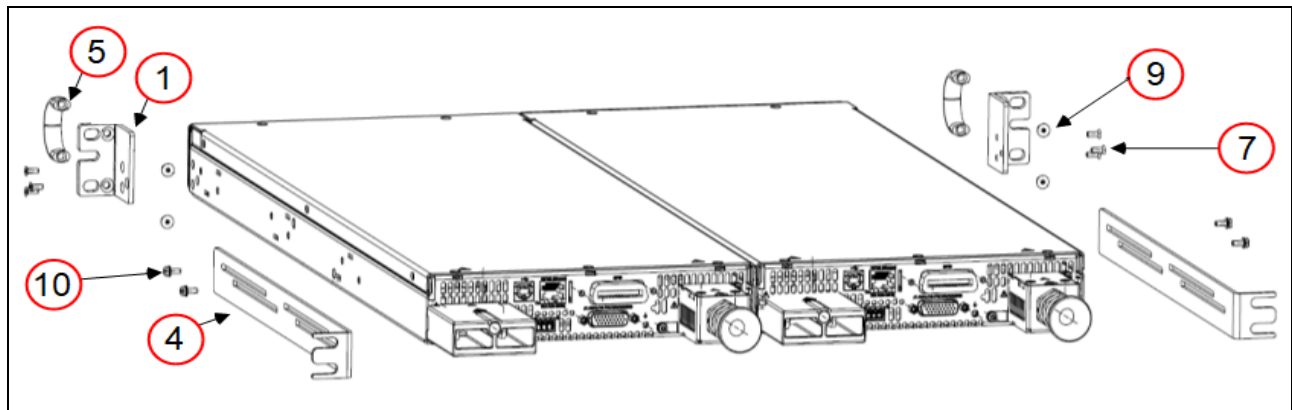

1. Attach the front corner (1) to the right and left sides of the assembly using six screws (7): Flat head screw M3X8.
2. Attach the handles (5) to both corner brackets using four screws (9): Flat head screw 10-32 x 3/8. The threaded holes in the handle should be oriented toward the outside of the rack assembly to allow enough room for the front panel dress screws.
3. Attach the movable brackets (4) to the sides of the assembly using the four screws (10): Flat head screw M3X8. Adjust the movable brackets to fit the depth of the cabinet.

## Rack Mounting 3.4 kW, 5 kW Units

### Standard Installation

1. Use the front panel rack-mount brackets to install the power supply in the rack.

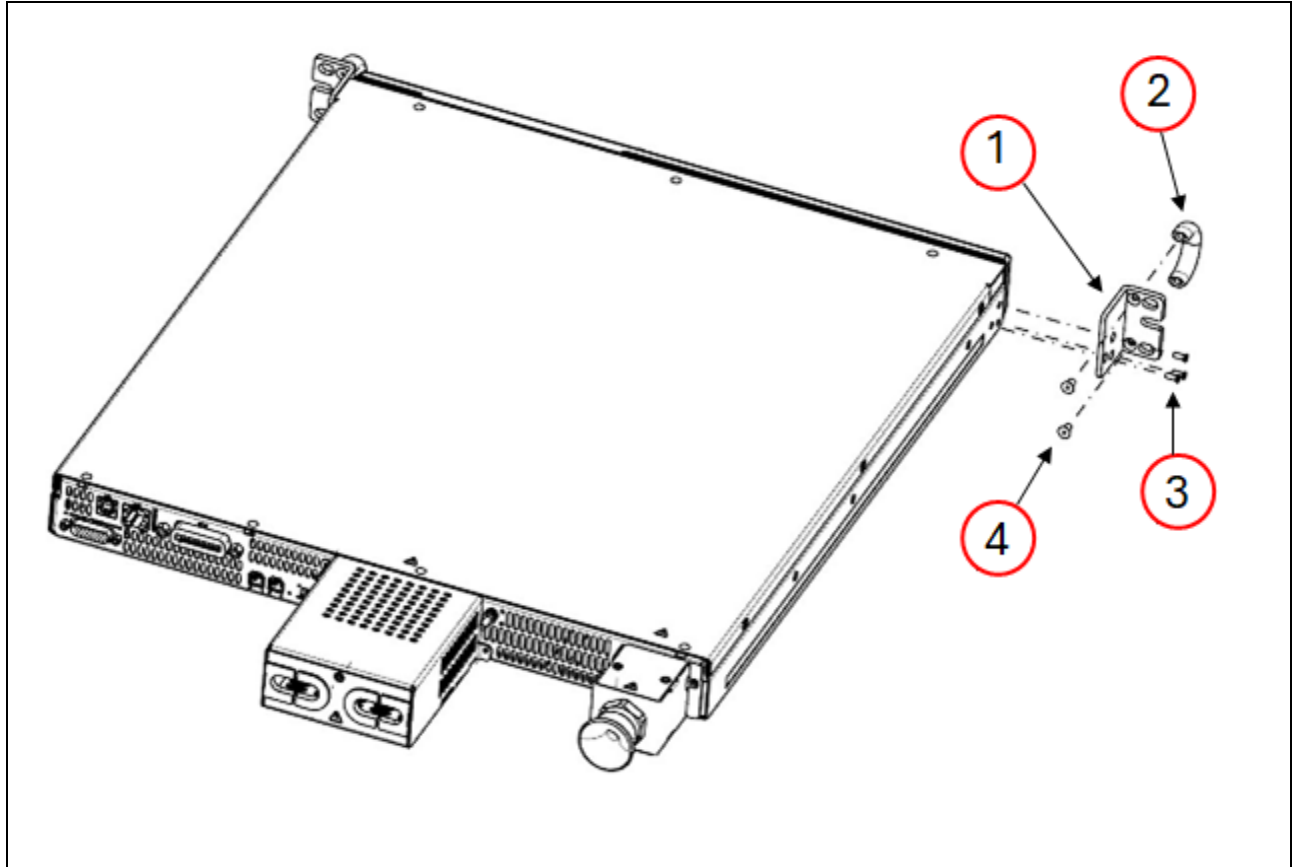

1. Attach the two Front Corners (1) to the right and left sides of the assembly using six Flat Head Screws M3X8 (3). Attach the two Handles (2) to the right and left sides of the assembly using two Flat Head Screws 10-32 x 3/8 (4).

To prevent internal damage, use the specified screw length only

2. Use a support bar to provide adequate support for the rear of the power supply. Do not obstruct the air exhaust at the rear panel of the Unit.

### Optional Rack Slides

Use rack mount slide kit N5740A. Refer to the installation instructions provided with the slide kit for details.

The following figure shows the rack mount components for the 3.4 kW, 5 kW units.

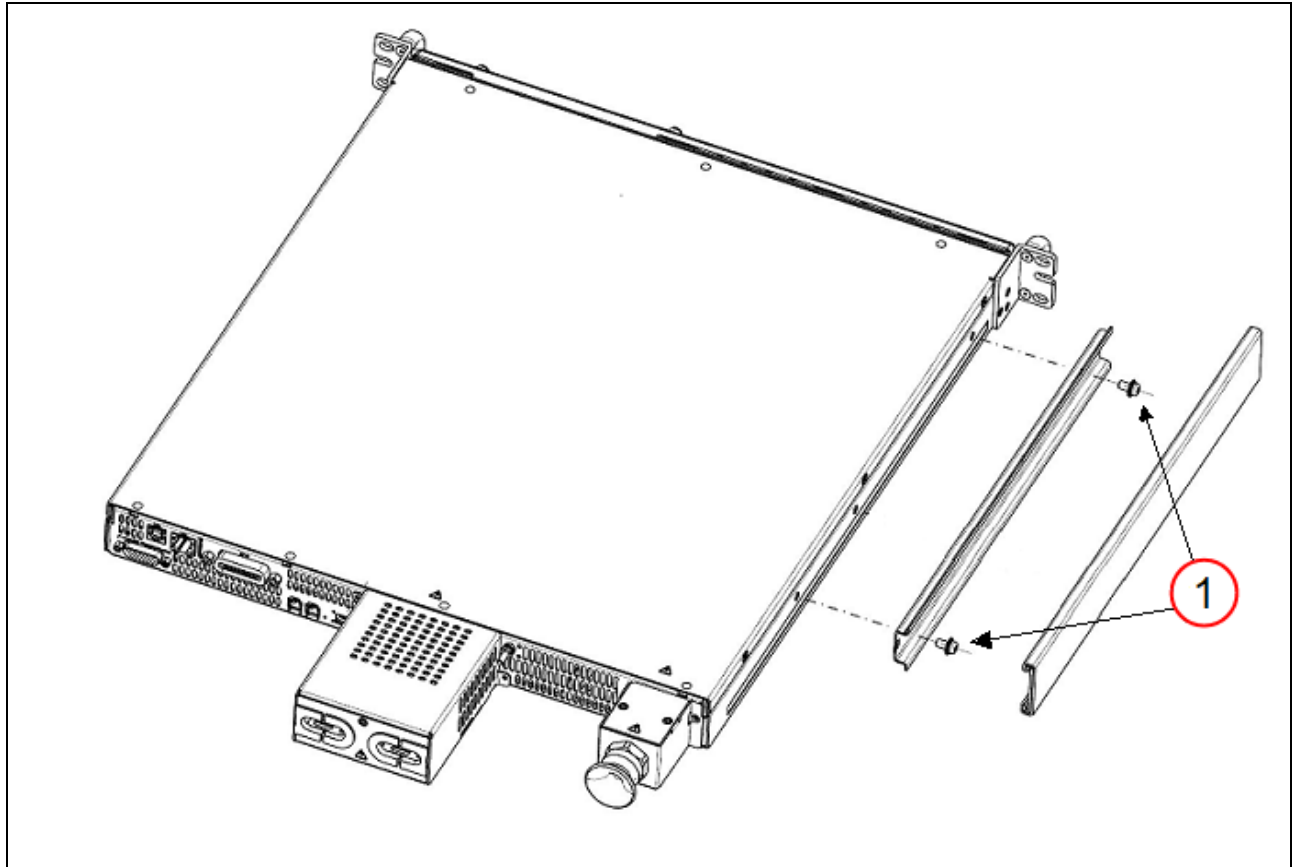

1. Attach the rack slides to the right and left sides of the assembly using four screws (1): Use four #10-32x0.38"(max.) screws at each side. Tightening torque: 25.4~31.7 lbf-inch

To prevent internal damage, use the specified screw length only

## AC Mains Connections

### Power Cables

### Power Connections

#### Power Cables

**NOTE**

Safety agency requirements dictate that there must be a way to physically disconnect the AC mains cable from the unit. A disconnect device, either a switch or circuit breaker must be provided in the final installation. The disconnect device must be close to the equipment, must be easily accessible, and must be marked as the disconnect device for this equipment. It must meet the input ratings requirements listed in the following table.

An AC mains power cable is not provided with the unit. Keep the AC mains cables as short as possible. The longer the cable, the greater the voltage loss due to cable resistance. If required by local electrical codes, install a fuse or circuit breaker between the AC mains and the unit.

Refer to the following table for the maximum current capacity requirements for each cable conductor. When selecting a cable, ensure that all local regulations and requirements are followed.

Product Power Rating	AC Input Range	Maximum Phase Current (A RMS)	Line Cord Outer Diameter Range (mm)
1.5 kW	100 VAC, 1-phase	19.7 A	4-10 mm
1.5 kW	110-130 VAC, 1-phase	17.9 A	4-10 mm
1.5 kW	190-240 VAC, 1-phase	10.4 A	4-10 mm
3.4 kW	190-240 VAC, 1-phase	22.6 A	9-14 mm
3.4 kW	190-240 VAC, 3-phase	13.1 A	9-14 mm
3.4 kW	380-480 VAC, 3-phase	6.5 A	9-14 mm
5.0 kW	190-240 VAC, 3-phase	19.3 A	9-14 mm
5.0 kW	380-480 VAC, 3-phase	9.7 A	9-14 mm

#### Power Connections

**WARNING**

**SHOCK HAZARD** The AC mains must include an earth ground connection. AC mains connections must be made by a qualified electrician who knows about 3-phase mains circuits and all applicable safety standards and requirements.

#### Prepare the AC cable

Strip the outside insulation (1) of the AC cable approx. 3 cm (1) for single phase inputs. Trim the wires so that the ground wire is 10 mm longer than the other wires.

Strip 10 mm at the end of each of the wires (2).

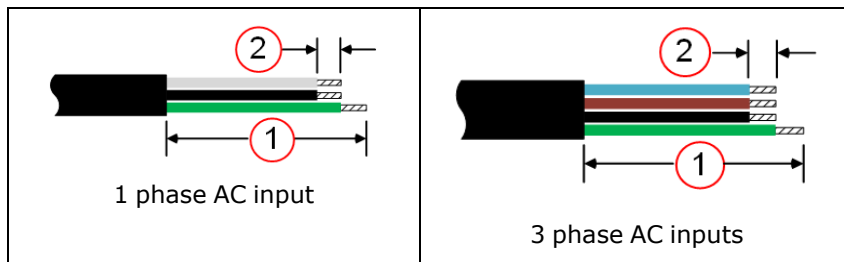

### Prepare the strain relief assembly

Insert the Cable gland (1) into the Strain relief bracket assembly (2).

Hand-tighten the plastic nut (3) from the inside part of the bracket. Do not apply excessive force.

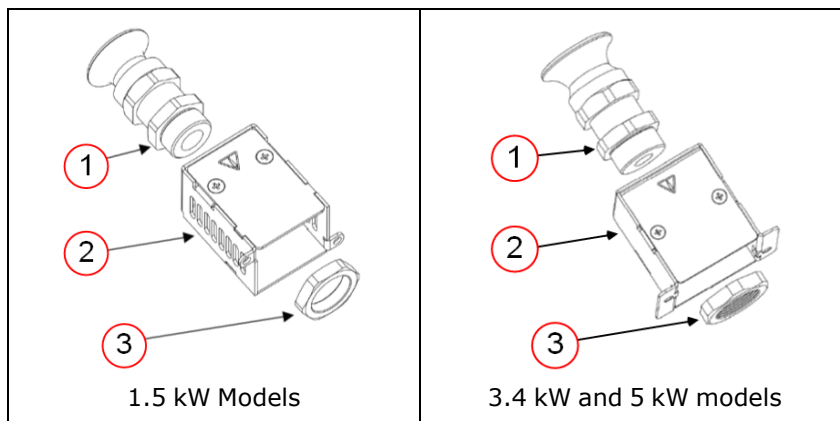

### Insert the AC cable

Unscrew the conical cable gland (1) until it is possible to insert the AC cable.

Insert the AC cable through the conic cable gland (2) and the strain relief bracket assembly.

Extend the stripped AC wires (3) far enough so that you can install the AC input connector (3).

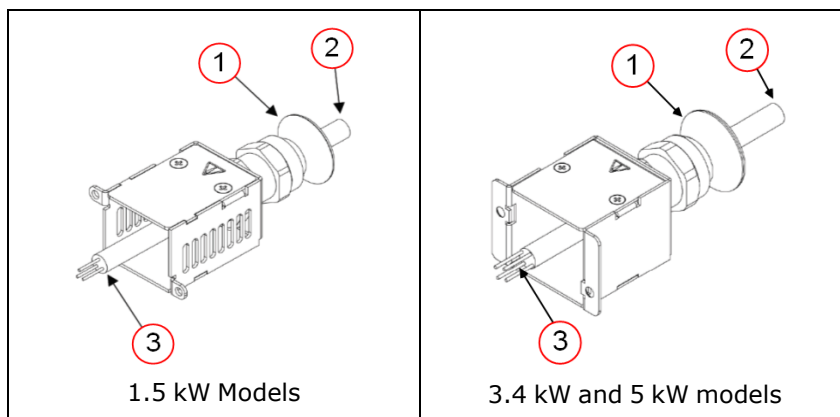

### Insert the wires into the AC plug

## 2 Installing the Instrument

Insert the AC wires (1) into the AC connector plug (2).

For proper wiring configuration, install the AC wires in the order shown in the following table based on the type of input (order assumes the user is looking at the rear of the unit). These configurations are also provided via labels on the provided AC connector plug, and the rear panel of the unit.

For 3-Phase Models – DP57XXAL & DP57XXAH				For 1-Phase Models – DP57XXA & DP57XXAS			
L1	L2	L3	⊕	~	~	⊕	

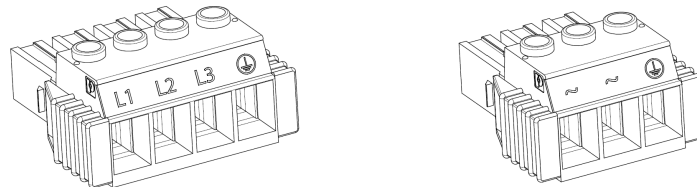

Tighten the AC connector screws, tightening torque: 4.5–5.3 lbf-inch. (0.5–0.6 Nm).

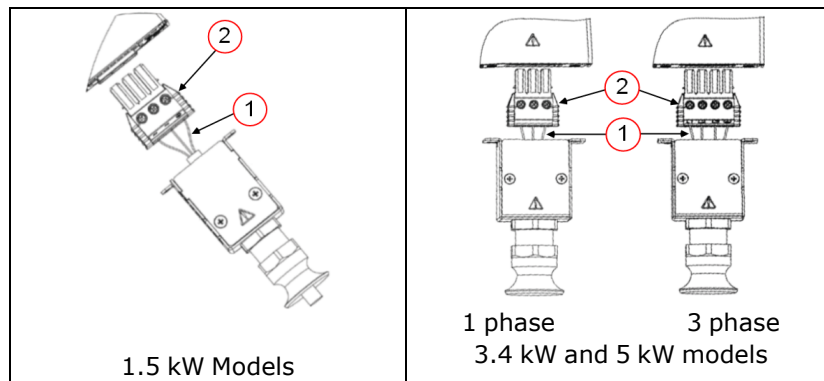

### Install the AC plug and strain relief assembly

Insert the AC connector plug into the AC input of the power supply. To remove the connector plug, push on the two yellow release tabs located on each side of the plug.

Fix the strain relief release assembly (1) to the rear panel with two M3x8 SEMS or flat-head screws (2). Tightening torque: 4.7–5.7 lbf-inch (0.53–0.64 Nm).

Hand-tighten the conic cable gland onto the AC cable (3). Do not apply excessive force.

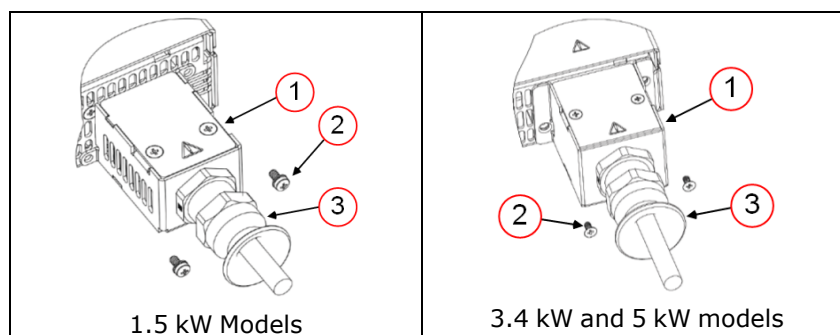

## Single Unit Connections

### Output Connections

### Single Load Connections

### Load Cable and Safety Cover Instructions

### Load Considerations

### Ferrite Core Installation - for 1.5 kW models only

### Grounding the Output

## Output Connections

**WARNING**

SHOCK HAZARD Turn off AC power before making rear panel connections.

Many models generate voltages above 60 VDC, with some models rated at up to 1,500 VDC! Ensure that all instrument connections, load wiring, and load connections are insulated or covered so that no accidental contact with lethal voltages can occur.

All rear panel connections must be made with the unit turned off, and must be performed by qualified personnel who are aware of the hazards involved. Improper actions can cause fatal injury as well as equipment damage.

Never touch cables or connections immediately after turning off the unit. Lethal voltages can remain between the output terminals for 10 seconds or longer after turn-off.

Ensure that any residual voltages present at the + and – output terminals are discharged before touching the output terminals. Use an independent DVM to measure the voltage between the + and – output terminals, and also from each terminal to ground.

To fully discharge the internal capacitances from the output terminals to ground, momentarily connect a DVM between the + output terminal and ground, and repeat this procedure for the – output terminal. The input resistance of the DVM, often about 10 M $\Omega$  on higher voltage ranges, will discharge the capacitances.

Use a DVM that is rated for the voltages you are measuring or discharging. For higher voltages, especially greater than 1000 V, you may need to use a precision voltage divider between the output terminals and the DVM.

Depending on the model, output terminals may be up to 1500 VDC from ground.

**Output Terminal Isolation** ratings must not be exceeded.

---

The following factors should be considered when wiring the load to the power supply:

## 2 Installing the Instrument

- Load wire current carrying capacity
- Load wire insulation rating (must be equivalent to the maximum output voltage)
- Load wire voltage drop
- Load wire noise and impedance effect

### Wire Sizes

**WARNING**

**FIRE HAZARD** To satisfy safety requirements, load wires must be large enough not to overheat when carrying the maximum short circuit current of the power supply. With more than one load, any pair of load wires must be capable of safely carrying the full-rated current of the supply.

---

The following table lists the characteristics of AWG (American Wire Gauge) copper wire. Paralleled wires may be substituted for single wires. For example, two AWG 3/0 (95 mm<sup>2</sup>) cables may be paralleled for units rated at 510 A. Paralleled load wires may be required for larger-ampacity power supplies.

AWG	Nearest Metric size	Ampacity (Note1)	Resistance (Note2)
18	1.0 mm <sup>2</sup>	up to 14 A	6.385 Ω
16	1.5 mm <sup>2</sup>	up to 18 A	4.016 Ω
14	2.5 mm <sup>2</sup>	up to 25 A	2.525 Ω
12	4 mm <sup>2</sup>	up to 30 A	1.59 Ω
10	6 mm <sup>2</sup>	up to 40 A	1.0 Ω
8	10 mm <sup>2</sup>	up to 60 A	0.63 Ω
6	16 mm <sup>2</sup>	up to 80 A	0.395 Ω
2	35 mm <sup>2</sup>	up to 140 A	0.156 Ω
1/0	50 mm <sup>2</sup>	up to 195 A	0.098 Ω
2/0	70 mm <sup>2</sup>	up to 225 A	0.078 Ω
3/0	95 mm <sup>2</sup>	up to 260 A	0.062 Ω
2 x3/0	2x95 mm <sup>2</sup>	up to 500 A	0.031 Ω

Note 1. Ampacity is based on a single conductor **in free air**, 26–30° C ambient temperature, with the conductor rated at 60° C. Ampacity ratings decrease when wires are bundled and at higher ambient temperatures.

Note 2. Resistance is in ohms/1000 feet, at 20° C wire temperature.

Along with conductor temperature, you must also consider voltage drop when selecting wire sizes. Although the power supply will compensate for the voltage in the load wires, it is recommended to minimize the voltage drop as much as possible to prevent excessive output power consumption from the power supply and poor dynamic response to load changes. Larger diameter wire sizes will help

minimize load-wire voltage drops. Twisting or bundling load wires will help reduce transient voltage drops.

## Single Load Connections

### WARNING

Ensure that the insulation rating of the load cables is greater than the voltage rating of the unit, which on some models is rated at up to 1500 Vdc.

A hardware kit is shipped with your unit. You must provide the cables and terminations. Ensure that the cable-mounting hardware does not short the output terminals.

The following figures illustrate the dimensions of the output bus bars of the various power supply models for installation purposes.

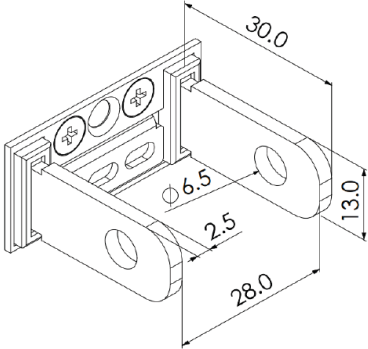
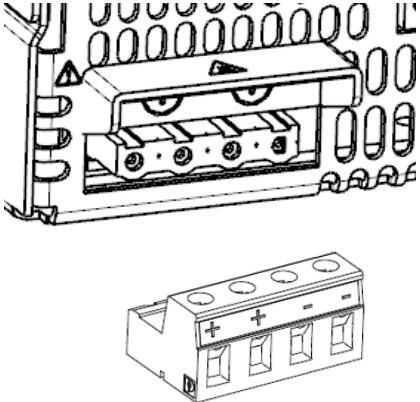
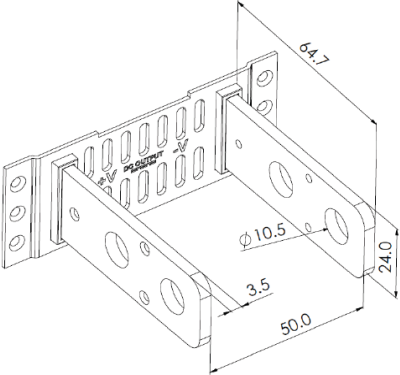
	
<p>10 - 100 V 1.5 kW models use bus bars</p>	<p>150 - 600 V 1.5 kW models use a plug-in connector</p>
	
<p>10 - 40 V 3.4 kW and 5 kW models</p>	

## 2 Installing the Instrument

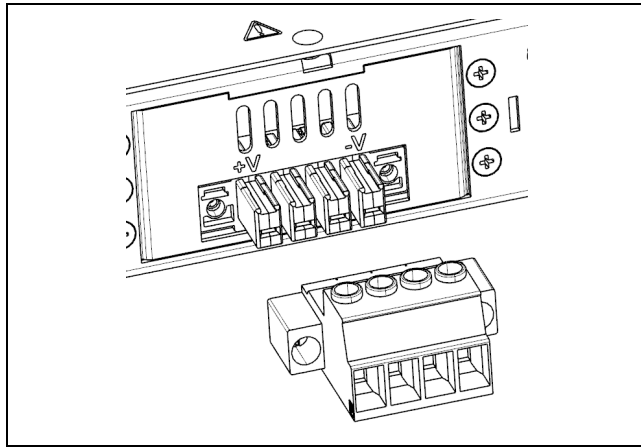

150 - 600 V 3.4 kW and 5 kW models use a plug-in connector

### Load Connections for 1.5 kW power supplies

As shown in the following figures, terminate all load wires with the proper wire terminal lugs securely attached. **DO NOT** use unterminated wires when making output connections at the power supply.

Route the load leads through the safety cover before attaching the safety cover to the rear panel.

#### NOTE

There is a maximum wire diameter limitation of 11 mm on the safety cover. If your load wires exceed this limitation, you must parallel two wires for each on each output terminal as shown in the figure on the right.

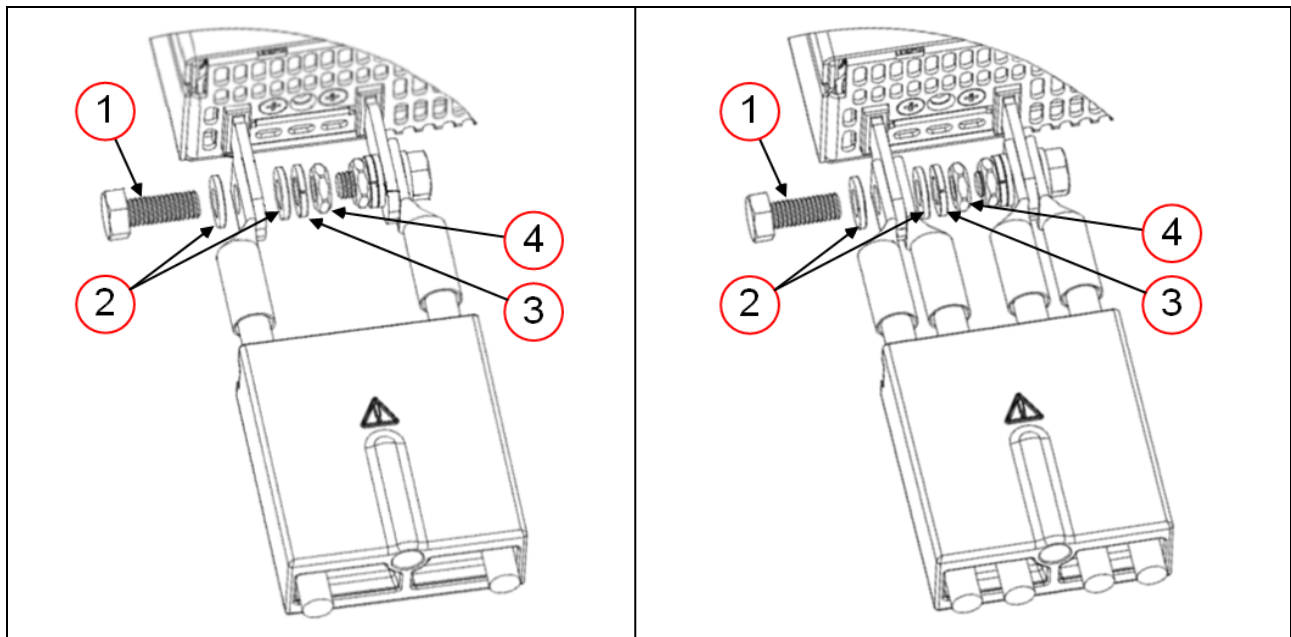

Attach the cable to the bus bar using the M6 screw (1), flat washers (2), spring washer (3), and M6 nut (4) as shown. Bolt tightening torque: 36.3-48.7 lb-in or 4.1-5.5 Nm

The 150 V to 600 V models have four terminal wire clamp output connector. The two left terminals are positive outputs and the two right terminals are the negative outputs. In case only two wires are connected to the load, insert the terminal plugs provided with the connector into the vacant terminals as shown in the figure on the right.

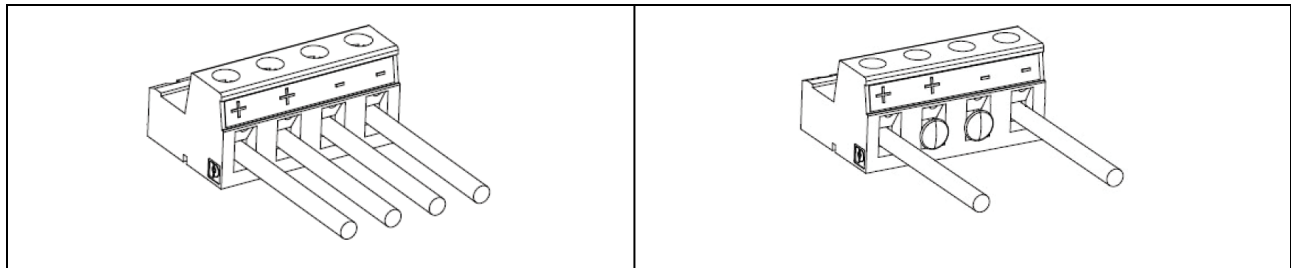

Strip the end of each wire approximately 10 mm. Insert the stripped wires into the terminals and tighten the terminal screws securely. Screw tightening torque: 4.4-5.5 lb-in or 0.5-0.6 Nm

Attach the safety cover to the unit to complete the installation.

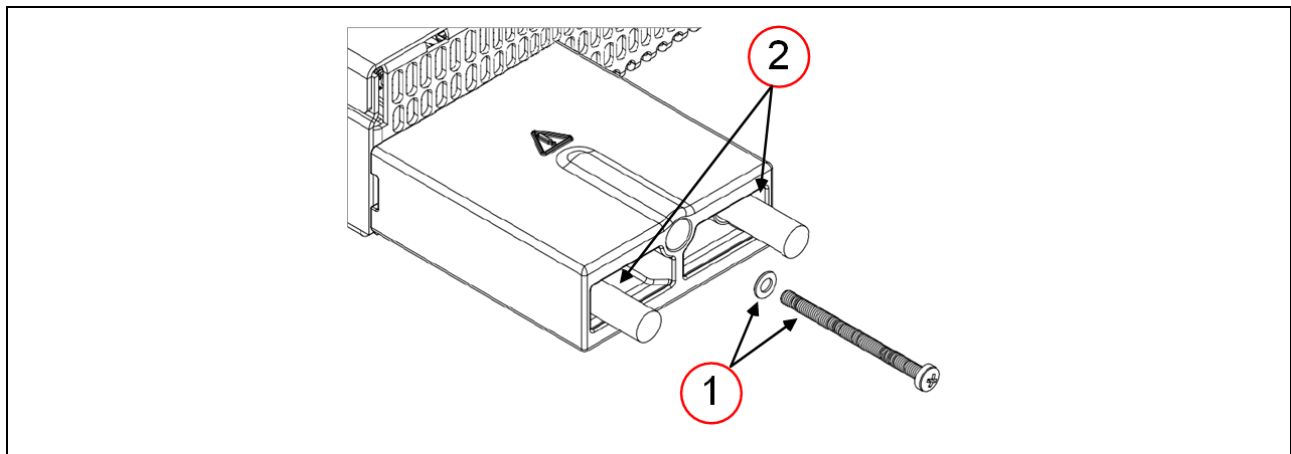

Attach the safety cover using the supplied washer and M30x40 screw (1).  
Screw tightening torque: 4.7 - 5.8 lb-in or 0.53-0.65 Nm  
The maximum wire size diameter for the safety cover is 11 mm (2).

**WARNING**

Remote sense wires are routes through the output cover for all 1000 V to 1500 V rated models.

Ensure that the insulation rating of the sense wires is greater than the voltage rating of the unit, which may be rated at up to 1500 VDC.

---

### Ferrite Core Installation - for 1.5 kW models only

For the applicable units, install the supplied ferrite core to reduce EMI (electromagnetic interference).

Run each output lead through the core 2 or 4 times as required for your model number according to the table below:

Model Numbers	Ferrite Core Provided	Required Number of Turns
DP5721A, DP5722A, DP5723A, DP5724A, DP5726A, DP5728A, DP5730A	Fair-Rite 2646803802	2
DP5731A, DP5733A	Fair-Rite 2646626402	2
DP5736A	Fair-Rite 2646804502	4

Place the core as close as possible to the output cover of the unit.

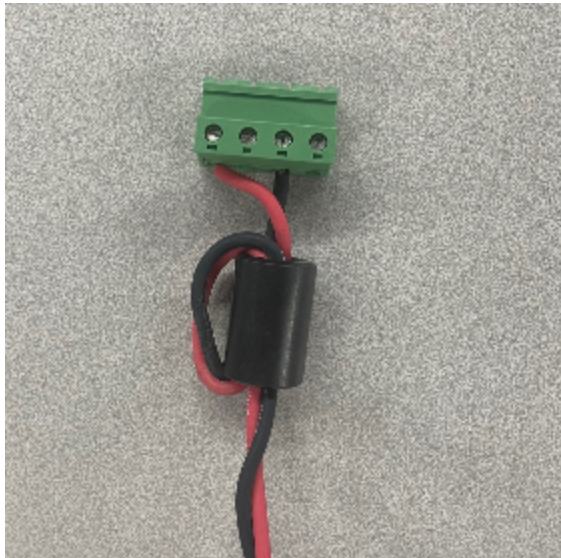

Sample setup for DP5733A model.  
Provided core and number of turns will vary based on Model Number.

## Load Cable and Safety Cover Instructions

### Use of the Safety Cover for the 3.4 kW and 5 kW units

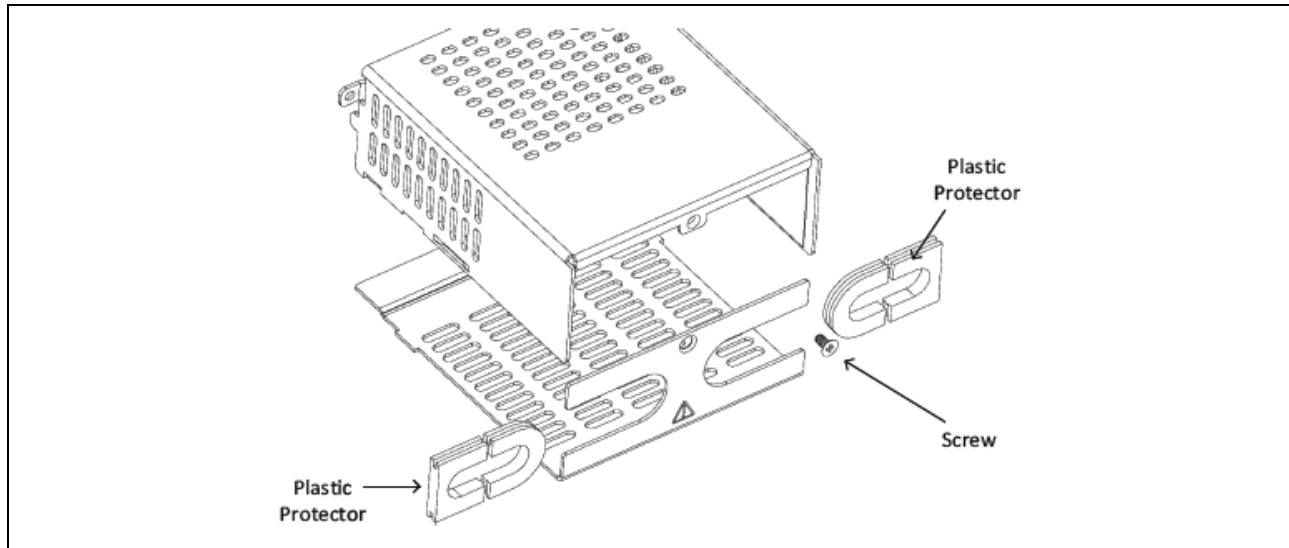

Open the output safety cover assembly (supplied in the accessory kit) by removing the screw on the rear side of the assembly as shown above.

Remove the Plastic Protectors and modify per the loading for each model case below.

### For the 3.4 kW and 5 kW: 10 V models:

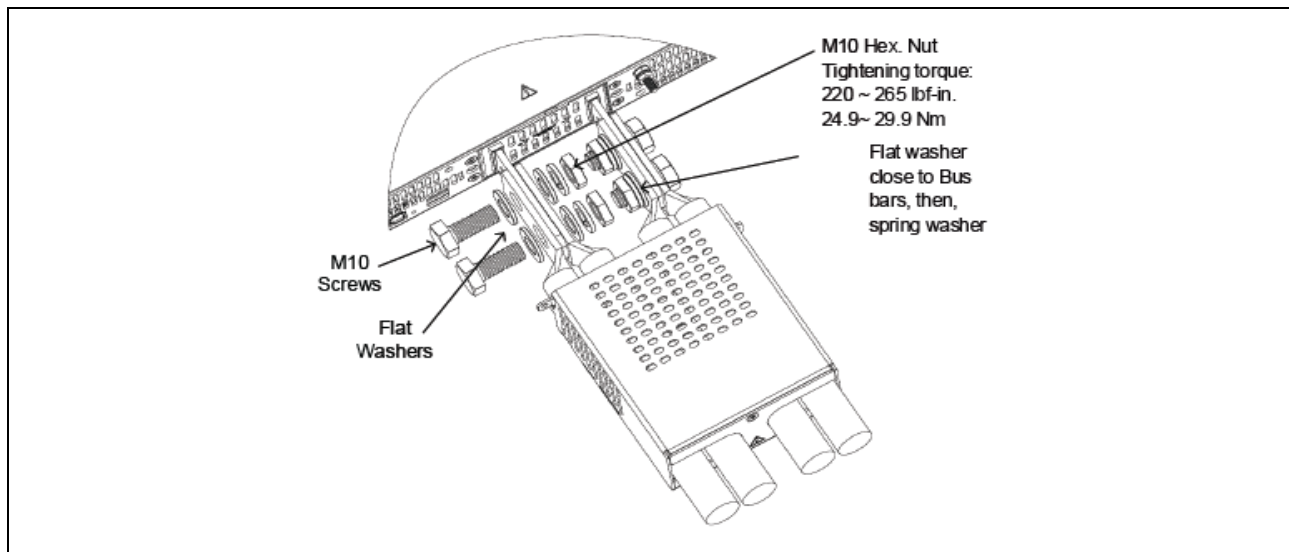

Fix the wires to the busbars as shown above. With these models the plastic protectors will not be required. Reattach the cover screw in the rear.

**For the 3.4 kW and 5 kW: 20-40 V models:**

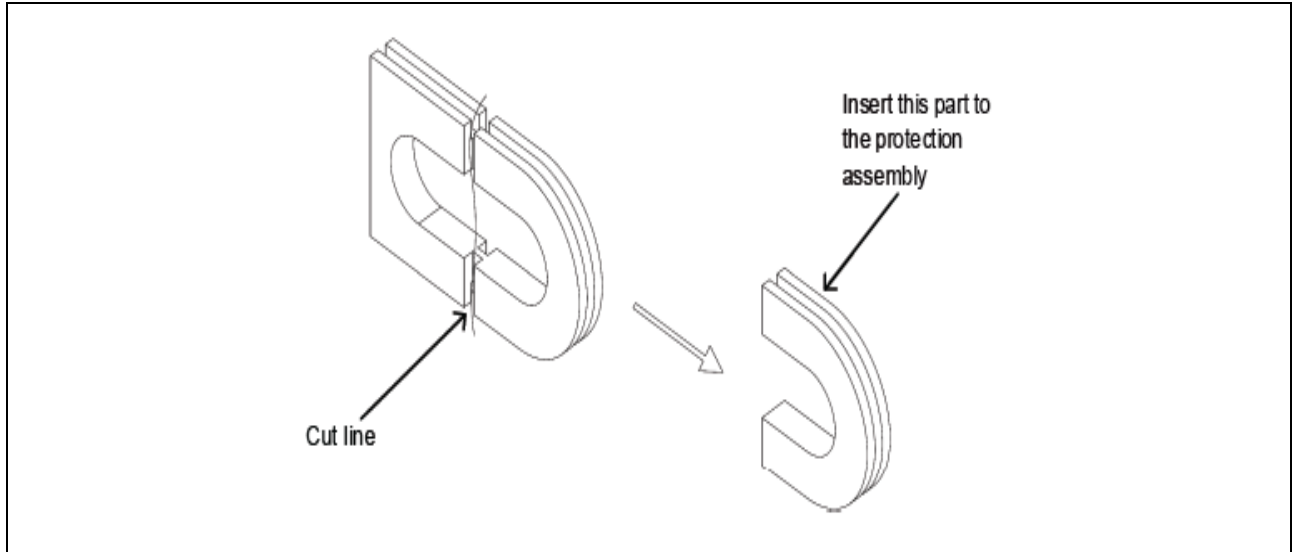

First, the plastic protectors need to be modified as follows: Remove and separate each plastic protector into two pieces by cutting the plastic bridge between the halves as shown above.

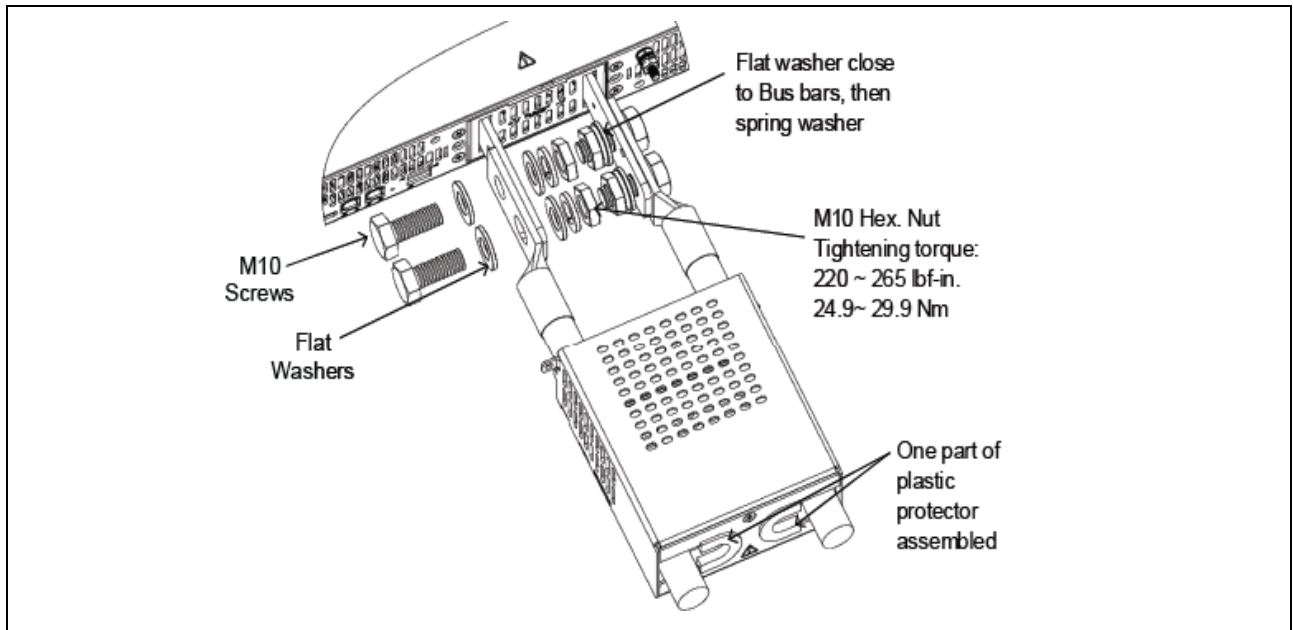

Fix the wires to the busbars as shown above. Close the cover assembly with one part of the plastic protector on each side. Reattach the cover screw in the rear.

**For the 3.4 kW: 60-100 V and 5 kW: 50-100 V models:**

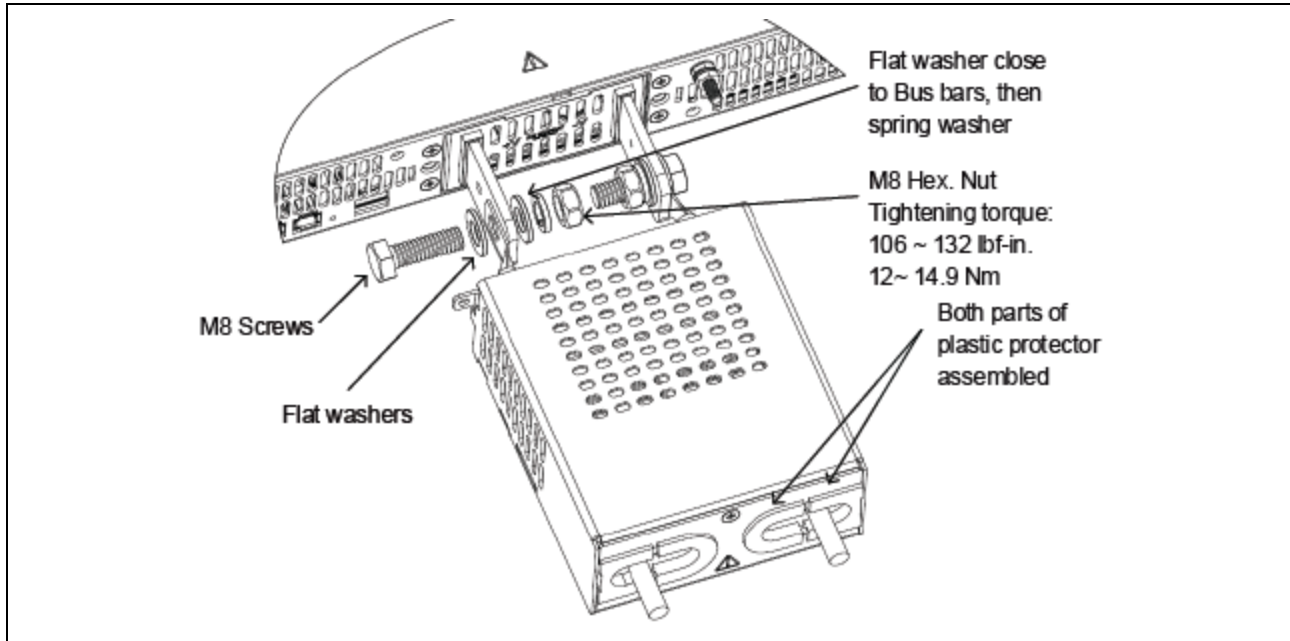

For these models there will be no need to disassemble the cover assembly nor modify the plastic protectors. Simply dress the wires through the rear and fix the wires to the busbars as shown above.

**For the 3.4 kW and 5 kW: 150-600 V models:**

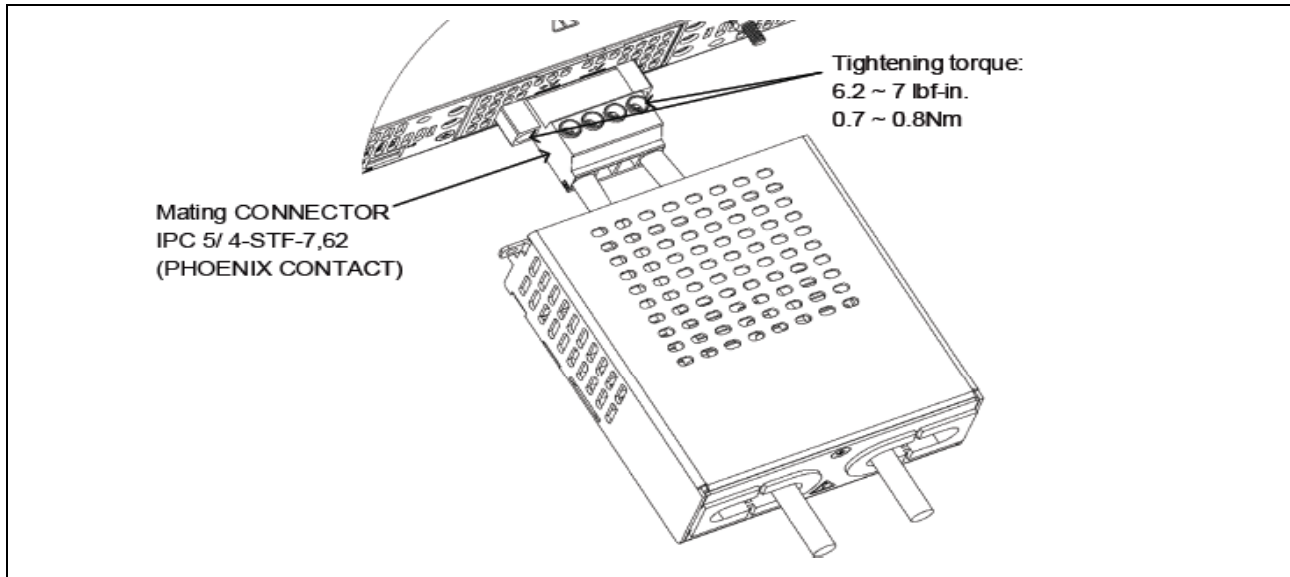

## 2 Installing the Instrument

A four terminal wire clamp connector Phoenix Contact p/n IPC 5/ 4-STF-7,62 has been provided. Connect the load wires as follows:

1. Refer to the **recommended load wire chart** for the correct gauge wire.  
Strip approx. 10 mm at the end of each wire.
2. Loosen the mating connector terminal screws.
3. Insert the wire through the output safety cover assembly.
4. Insert the stripped wires into the terminals and tighten the terminal screws  
Tightening torque: 6.2–7 Lbf-inch. (0.7–0.8 Nm).
5. Tighten the mating connector to the power supply rear panel as shown above.  
Tightening torque: 6.2–7 Lbf-inch. (0.7–0.8 Nm)

### For all 3.4 kW and 5 kW models:

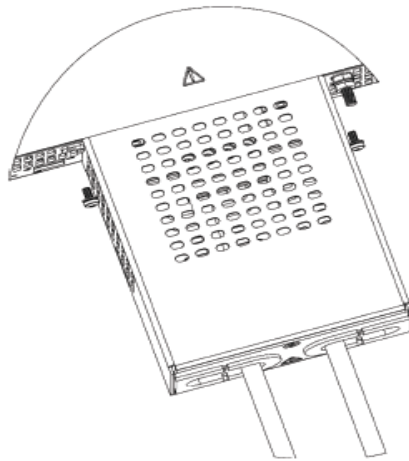

Attach the safety cover assembly to the rear of the power supply by using 2 M3X8 SEMS screws from the accessory kit. Tightening torque: 4.7–5.7 Lb.-inch (0.53–0.64 Nm).

The following applies for all models:

## Output Voltage Sensing

Local or Remote voltage sensing can be selected either from the front panel or via a SCPI command. From the front panel, press the SYST key, and then navigate to the SENSE menu item.

From SCPI, use the command `VOLTage:SENSe <LOCal | REMote>`.

When remote sensing is in use, the REM indicator on the front panel is illuminated.

## Local Sensing

In local sensing mode, the power supply regulates the output voltage at the output terminals. As this method does not compensate for voltage drop on the load wires, therefore it is recommended only for low load current applications or where the load regulation is less critical. The following figure illustrates local sensing at the output terminals.

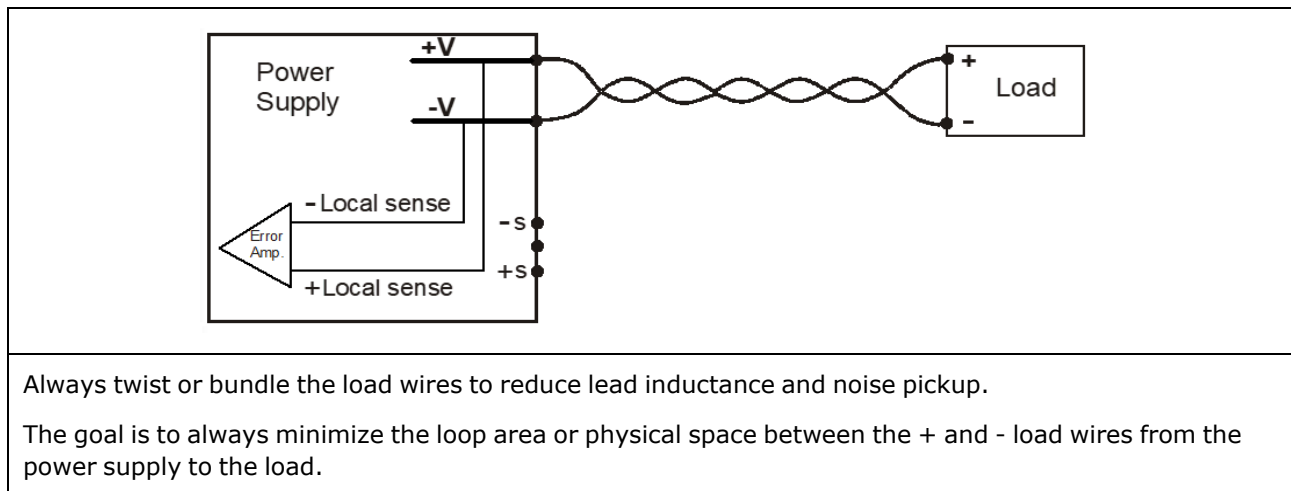

## Remote Sensing

### WARNING

**WARNING SHOCK HAZARD** There is a potential shock hazard at the sense connector when using a power supply with a rated output greater than 60 V. Ensure that the local sense and remote sense wiring insulation rating is greater than or equal to the maximum output voltage of the power supply. Ensure that the connections at the load end are shielded to prevent accidental contact with hazardous voltages.

### CAUTION

**Equipment Damage** Always connect the + sense lead to the + terminal of the load and the - sense lead to the - terminal of the load. If a sense lead opens during operation the output may momentarily overshoot. The two center sense terminals are not used.

Remote sensing improves the voltage regulation at the load by monitoring the voltage at the load rather than at the output terminals. This lets the power supply compensate for the voltage drop in the load leads. Remote sensing is useful for CV operation with load impedances that vary or have

## 2 Installing the Instrument

significant lead resistance. It has no effect during CC operation. Because sensing is independent of other power supply functions, remote sensing can be used regardless of how the power supply is programmed.

Note that the sense leads carry only a few milliamperes of current and can be a much lighter gauge than the load cables. However, note that any voltage drop in the sense leads can degrade the output voltage regulation. Try to keep the sense lead resistance less than about  $0.5\ \Omega$  per lead (this requires 20 AWG/1.0 mm<sup>2</sup> or heavier for a 50 foot length).

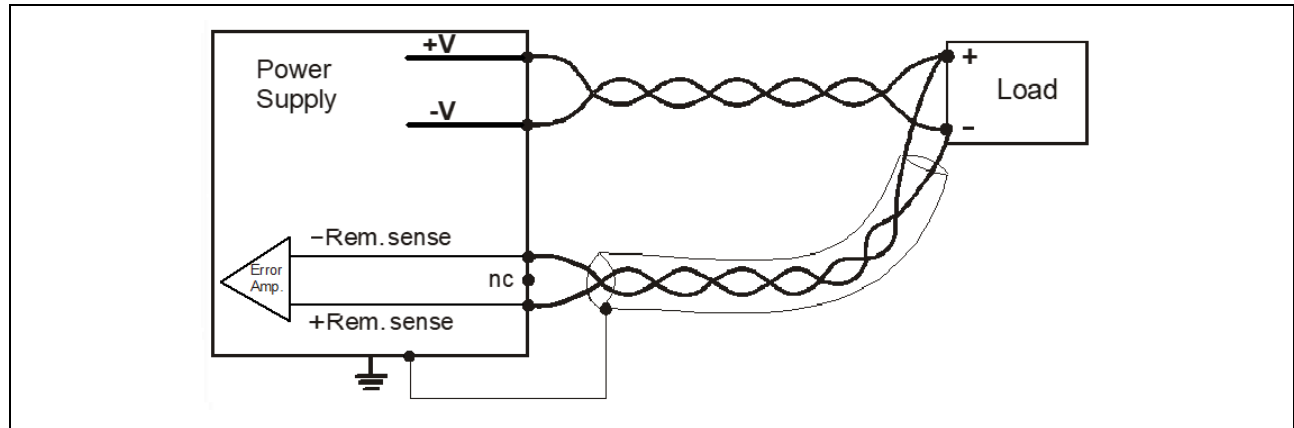

Connect the sense leads as close as possible to the load.

Do NOT bundle the sense wire-pair together with the load wires.

Keep the load wires and sense wires separate.

Keep the sense wire-pair as short as possible and twist or shield it to reduce lead inductance and noise pickup.

## Load Considerations

### Multiple Load Connections

If you are using local sensing and are connecting multiple loads to one output, connect each load to the output terminals using separate load wires as shown in the following figure. This minimizes mutual coupling effects and takes full advantage of the power supply's low output impedance.

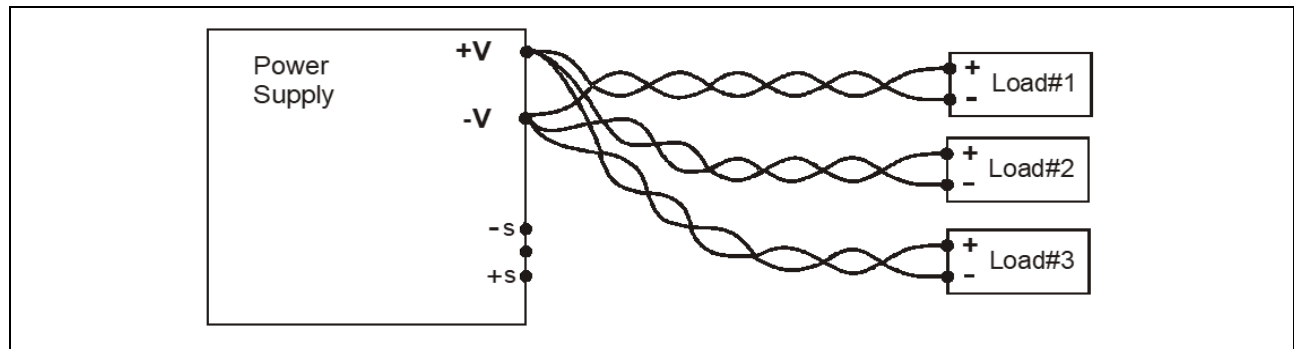

Keep each wire-pair as short as possible and twist or bundle the wires to reduce lead inductance and noise pickup.

The goal is to always minimize the loop area or physical space between the + and - load wires from the power supply to the load.

If load considerations require the use of distribution terminals that are located away from the power supply, twist or bundle all wire pairs from the output terminals to the remote distribution terminals as well as from the distribution terminals to the loads.

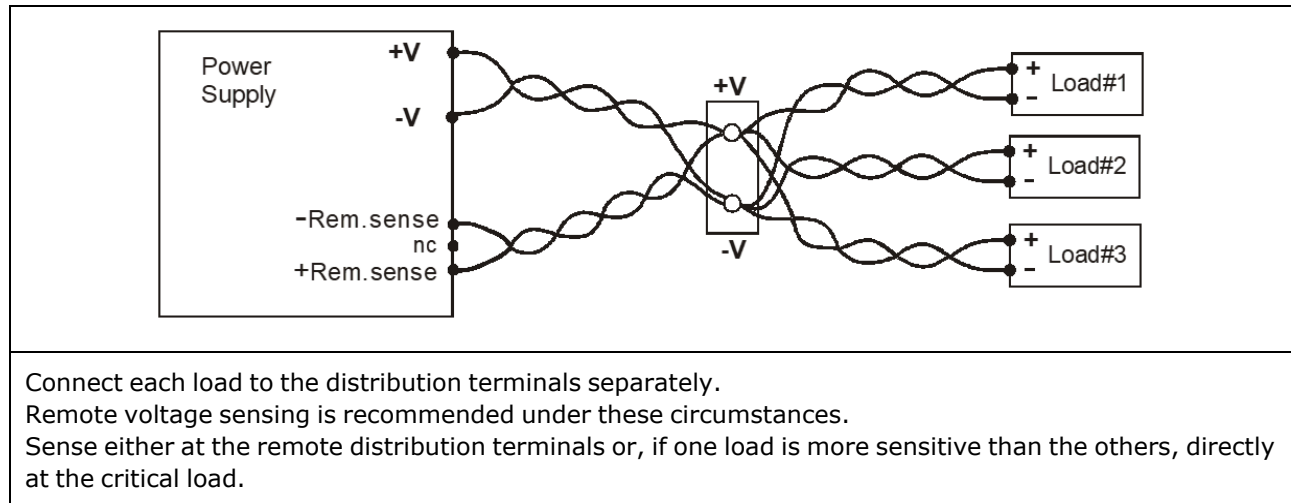

## Over-voltage Protection

Remote over-voltage protection (OVP) provides a customer-configurable over-voltage protection. When combined with remote voltage sensing, this allows for more precise voltage protection directly at the load. The OVP circuit monitors the voltage at the + and - sense terminals if remote sensing is selected, or at the output terminals if local sensing is selected. Refer to **Programming Output Protection** for further information.

## Output Noise

Any noise picked up on the sense leads will appear at the output terminals and may adversely affect CV load regulation. Twist the sense leads or use a ribbon cable to minimize the pickup of external noise. In extremely noisy environments it may be necessary to shield the sense leads. Ground the shield at the power supply end only; do not use the shield as one of the sensing conductors.

## Grounding the Output

Either positive or negative voltages with respect to ground can be obtained from the output by grounding (or "commoning") one of the output terminals. Always use two wires to connect the load to the output regardless of where or how the system is grounded.

### **WARNING**

Depending on the model, output terminals may be up to 1500 VDC from ground. **Output Terminal Isolation** ratings must not be exceeded.

## 2 Installing the Instrument

### CAUTION

**Equipment Damage** Before grounding any output terminal, check to see if the load is already grounded. Incorrect grounding could result in a short circuit.

---

## Multiple Unit Connections

### Parallel Connections

### Series Connections

#### WARNING

**SHOCK HAZARD** Turn off AC power before making rear panel connections.

Many models generate voltages above 60 VDC, with some models rated at up to 1,500 VDC! Ensure that all instrument connections, load wiring, and load connections are insulated or covered so that no accidental contact with lethal voltages can occur.

All rear panel connections must be made with the unit turned off, and must be performed by qualified personnel who are aware of the hazards involved. Improper actions can cause fatal injury as well as equipment damage.

Never touch cables or connections immediately after turning off the unit. Lethal voltages can remain between the output terminals for 10 seconds or longer after turn-off.

Ensure that any residual voltages present at the + and – output terminals are discharged before touching the output terminals. Use an independent DVM to measure the voltage between the + and – output terminals, and also from each terminal to ground. To fully discharge the internal capacitances from the output terminals to ground, momentarily connect a DVM between the + output terminal and ground, and repeat this procedure for the – output terminal. The input resistance of the DVM, often about 10 M $\Omega$  on higher voltage ranges, will discharge the capacitances.

Use a DVM that is rated for the voltages you are measuring or discharging. For higher voltages, especially greater than 1000 V, you may need to use a precision voltage divider between the output terminals and the DVM.

## Parallel Connections

See below for detailed instructions on installing the Auto Parallel Cables.

#### CAUTION

**Equipment Damage** Only connect power supplies that have identical voltage and current ratings in parallel.

Ensure that the connections between –V terminals are secure to prevent disconnection during operation. Disconnection may cause damage to the power supply.

## 2 Installing the Instrument

Multiple units of the same voltage and current ratings can be connected in parallel to provide increased output current capability. One of the units operates as the primary while the remaining units operate as secondaries. The configuration of the system (Primary/Secondary) is automatic. Each unit configures itself according to the auto parallel cable connections.

For the number of paralleled units supported, see the Supplemental Characteristics for each power level. See also [Parallel System Operations](#).

Parallel connections are established by connecting the primary unit to the secondary units using the auto parallel cable. Refer to the following figures, which illustrate how to connect three units in parallel.

### Local sensing

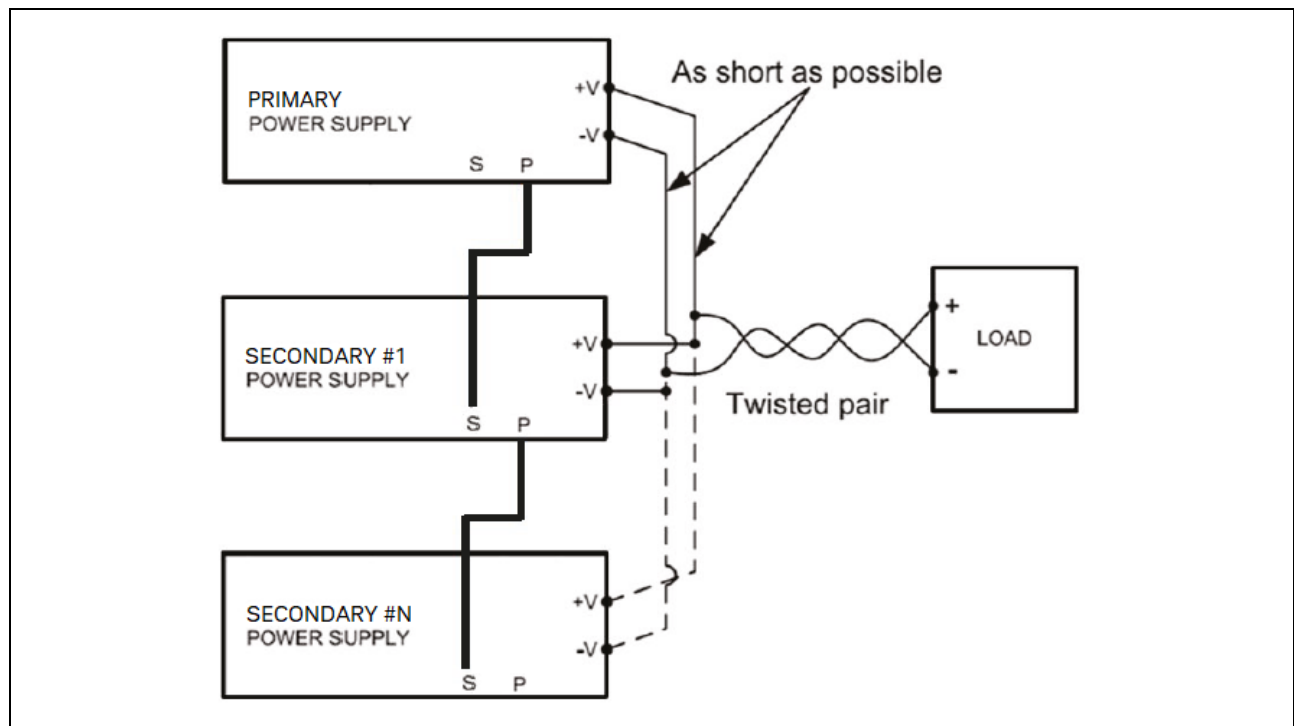

Connect the J7 (P) output connector from the primary unit to the J6 (S) input connector of the secondary unit. To connect additional units, connect J7 (P) connector to the next unit J6 (S) connector. Repeat the procedure until all the units are connected.

#### NOTE

To ensure correct initialization of the parallel system, the power supplies should be disconnected from the AC mains while connecting or disconnecting auto parallel cables to connectors J6 and J7.

Always twist or bundle the load wires to reduce lead inductance and noise pickup.

The load wire lengths to each power supply should be as close as possible to each other to achieve better current balance between power supplies.

### Remote Sensing

If remote sensing is desired to compensate for the lead drops, connect the remote sense leads of the Primary unit directly to the load. Remote sensing is recommended, but not required (see **Output Voltage Sensing**).

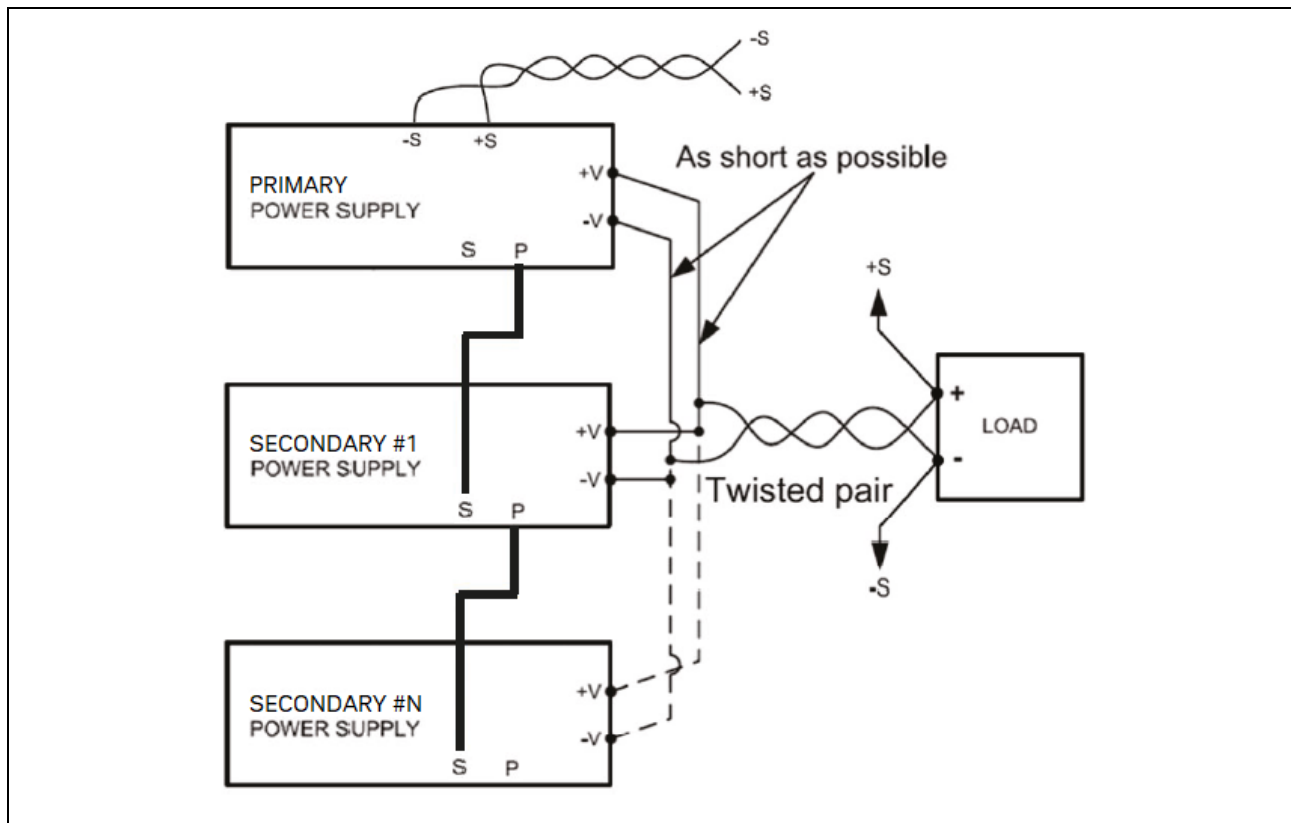

### Parallel System Acknowledge

Following initial system assembly, the new paralleled system has to be acknowledged. Any further change in the system configuration also has to be acknowledged. A change in the system can involve removing secondary units, adding additional secondary units, or changing the role of a unit from secondary to primary.

The acknowledge process is performed on the primary unit.

Front Panel Menu	SCPI Command
Turn on the primary unit and wait 5 seconds. The following message will appear on the front panel display: WAIT ACK.	To acknowledge the configuration: <b>INSTrument:GROup:ACKnowledge</b>
Press the Current knob to acknowledge the configuration.	
The display blinks, indicating that the parallel configuration is accepted	

## 2 Installing the Instrument

### Auto Parallel Cable DP5706A Installation

Primary Secondary Cable, Short (DP5741AS-80002)

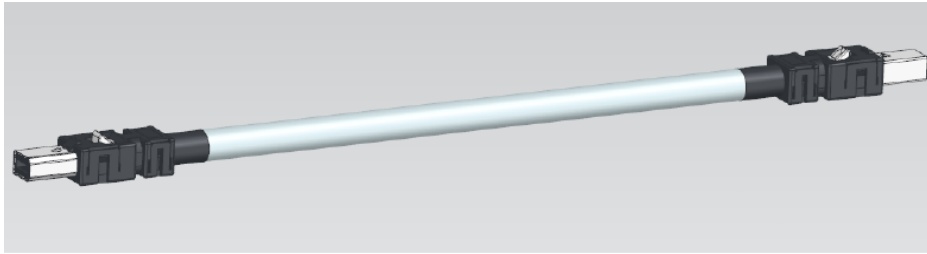

**NOTE**

Turn unit off and disconnect from AC Mains during installation.  
See the **Warning above**.

---

1. Note the Keying and Connector Release on the Connector Housing:

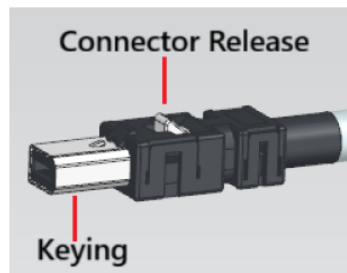

2. Connecting to the Units:

On the rear of the units, the Primary Connection is on the right and the Secondary on the left. Connect one end of the auto parallel cable to the Primary and the other end to the Secondary. Note the shape and keying of the connectors and ensure that the connector release is up when making the connection.

3. When paralleling more than 2 units, repeat this process, Primary to Secondary, for each successive unit.

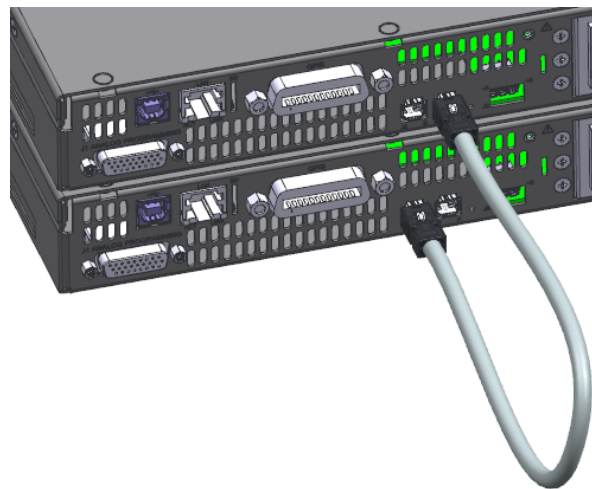

## Series Connections

**WARNING** Series operation is not supported for units with voltage ratings of 600 VDC or above.

When power supplies are connected in series, the **Output Terminal Isolation** ratings must not be exceeded.

**CAUTION** **Equipment Damage** Only connect power supplies that have identical voltage and current ratings in series.

Two units can be connected so that their outputs are summed.

Refer to the following figures for series operation with local and remote sensing (see **Output Voltage Sensing**).

### Local sensing

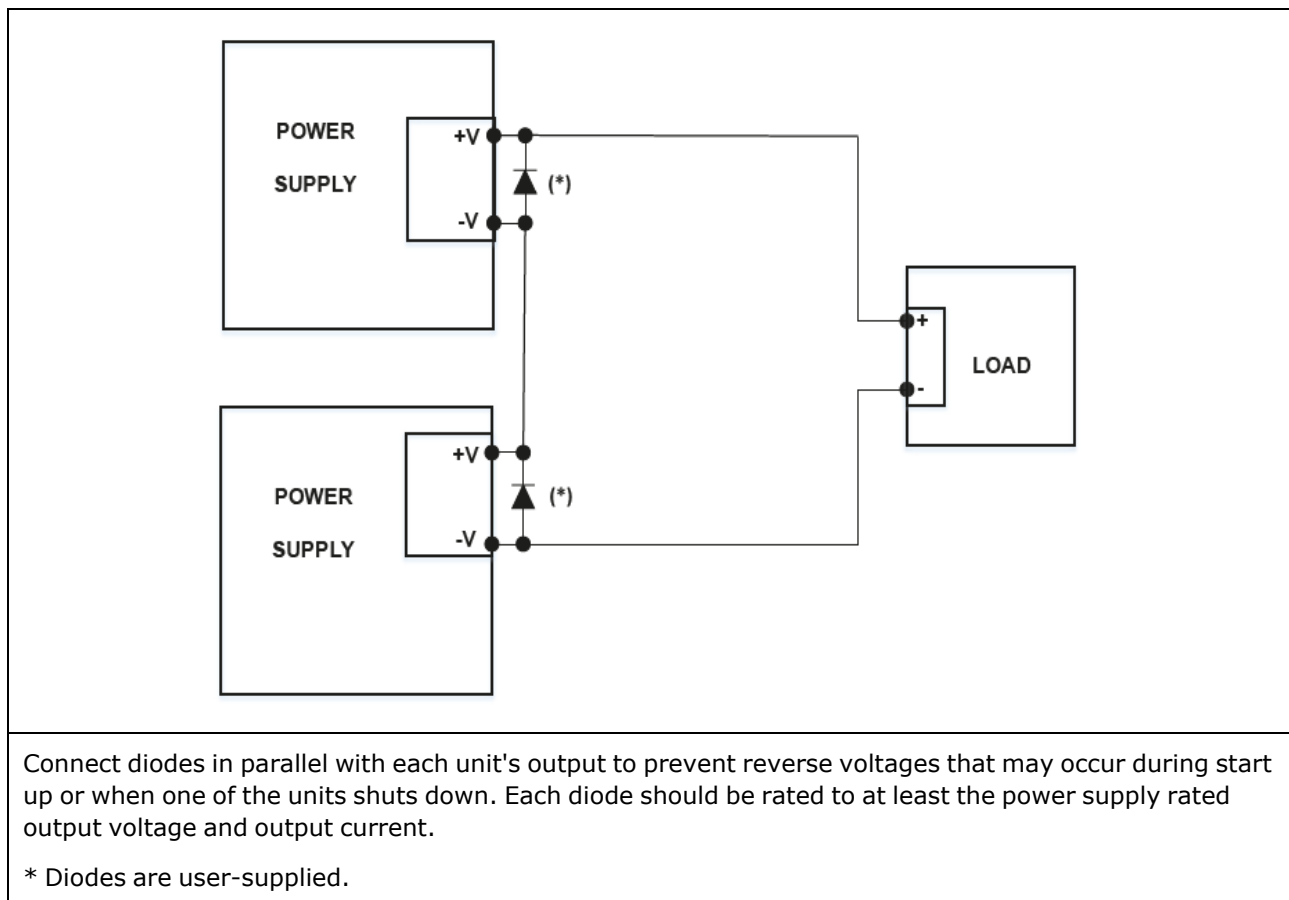

## 2 Installing the Instrument

### Remote Sensing

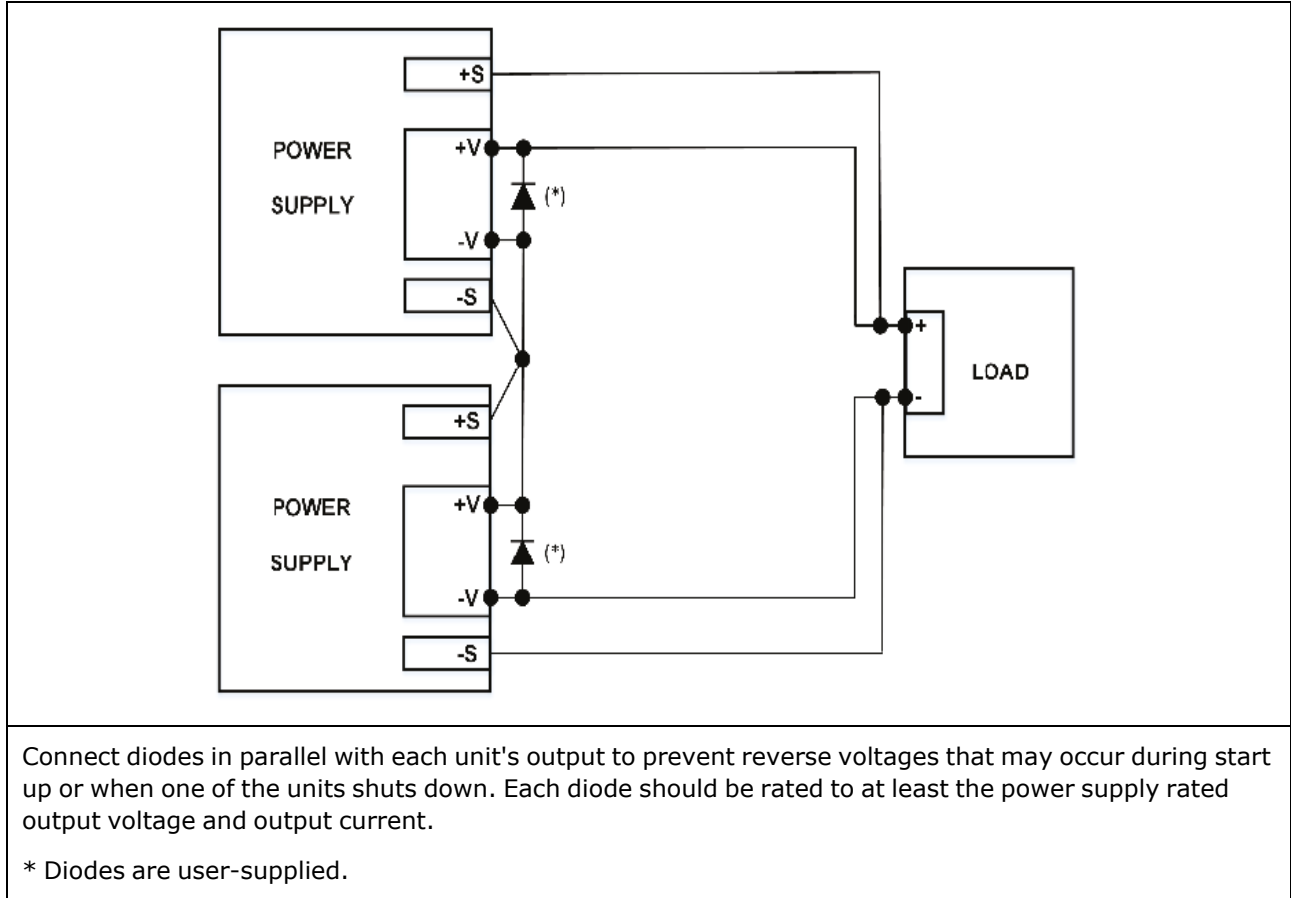

### Positive and Negative Output Voltages

In this mode, two units are configured as positive and negative output.

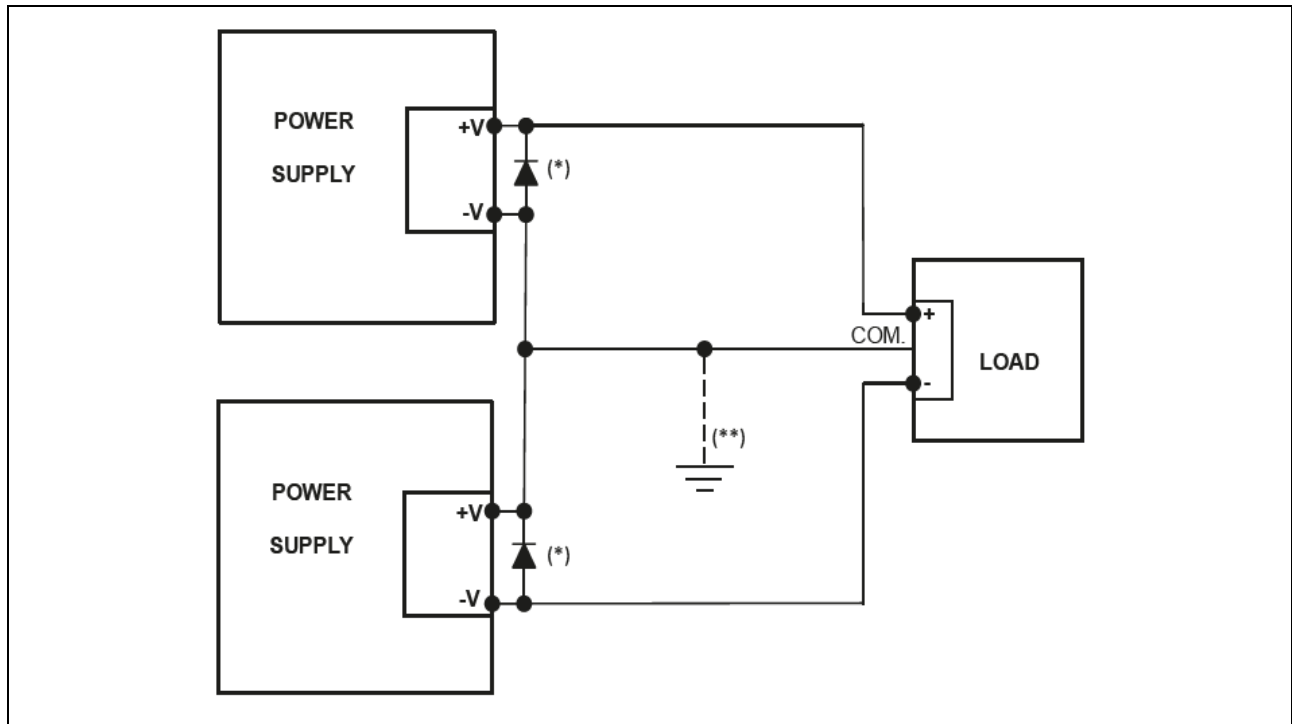

Connect diodes in parallel with each unit's output to prevent reverse voltages that may occur during start up or when one of the units shuts down. Each diode should be rated to at least the power supply rated output voltage and output current.

\* Diodes are user-supplied.

\*\* Optional ground connection.

## External Control Signal Connections (Analog)

External control signal connections are made through the 26 pin "Analog" connector (Type: Sub-D, D-Sub) on the rear of the unit. Use a standard connector plug (customer-supplied) to make all connections. Remember to turn **off** the unit before making any rear panel connections.

**CAUTION**

**Equipment Damage** The external control interface is galvanically separated from DC output and referenced to earth ground. Therefore, never connect a ground from the external control interface to the +DC or -DC outputs. Use an isolated, ungrounded, programming source to prevent ground loops when using the external control interface.

---

### Pin Assignments

The following figure identifies the pins on the external control signal connector (labeled "Analog" on the rear panel).

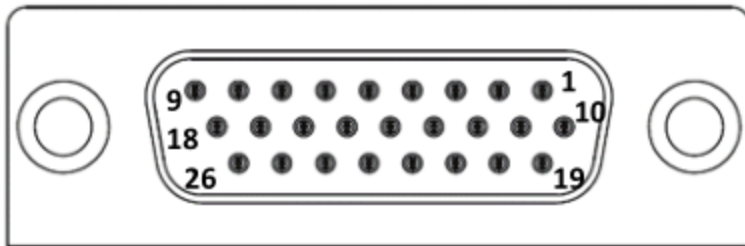

You must provide the mating plug for the external control signal connector. Use a 26-pin D-subminiature connector.

For information on using the external control functions refer to [J1 Connector Pin Functions](#) and [External Control Signal Programming](#).

# 3

## Using the Power Supply Locally

**Turn-On Checkout**

**Programming the Output**

**Programming Output Protection**

**Programming Output Lists**

**External Control Signal Programming**

**System-Related Operations**

You may want to read [Front-Panel Menu Reference](#) first. See [SCPI Programming Reference](#) for details on the SCPI commands to program the instrument.

## Turn-On Checkout

### Before Turn-On

#### Constant Voltage Check

#### OVP Check

#### UVL Check

#### Constant Current Check

### Before Turn-On

Ensure that the power supply is configured as follows:

- The unit is connected to the proper AC mains (see chapter 2).
- The POWER switch is in the off position.

**WARNING**

**SHOCK HAZARD** Be aware that hazardous voltages can be present on the output terminals. Do not set the output voltage above 60 VDC during the turn-on checkout procedure.

---

The following figure shows the output controls used during the turn-on checkout.

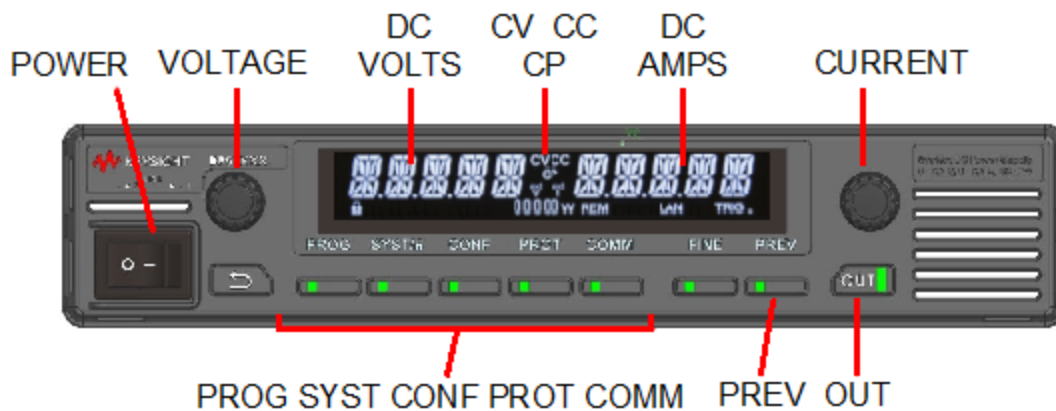

For a map of the front panel menu commands, refer to [Front Panel Menu Reference](#).

For a description of the status indicators, refer to [Front Panel Display at a Glance](#).

### Constant Voltage Check

1. Turn the POWER switch on.
2. If the REM indicator is illuminated -- Press the SYST key and rotate the current knob on the right until the display shows SENS LOCAL, then press the current knob to accept the setting.
3. Turn the output on by pressing the OUT key. The green OUT indicator should be illuminated.
4. The CV indicator should also be illuminated. If the CC indicator is illuminated, rotate the current knob on the right until the CV indicator becomes illuminated.
5. Rotate the voltage knob on the left while observing the DC VOLTS display. The output voltage should vary while the knob is turned. The voltage range is from zero to the maximum rated output for the power supply model.

### OVP Check

1. Rotate the voltage knob and set the output voltage of the unit to 50% of its full-scale rating or 30 volts, whichever is lower.
2. Press the PROT key once so that the DC VOLTS display indicates OVP. The DC AMPS display shows the OVP level.
3. Use the current knob and set the OVP level of the unit to 75% of its full-scale voltage rating or 40 volts, whichever is lower. Press the current knob to accept the setting.
4. Wait a few seconds until the DC VOLTS display returns to show the output voltage.
5. Use the voltage knob and raise the output voltage of the unit until it approaches the OVP setting. Check to make sure that the output voltage cannot be set higher than the OVP setting.
6. Press the PROT key again. Rotate the current knob and reset the OVP level of the unit to its maximum setting. Press the current knob to accept the setting.

### UVL Check

1. Press the PROT key once. Rotate the voltage knob until the DC VOLTS display indicates UVP.LV. The DC AMPS display shows the UVP level.
2. Use the current knob and set the UVL level of the unit to 50% of its full-scale voltage rating or 30 volts, whichever is lower. Press the current knob to accept the setting.
3. Wait a few seconds until the DC VOLTS display returns to show the output voltage.
4. Use the voltage knob and lower the output voltage of the unit until it approaches the UVL setting. Check to make sure that the output voltage cannot be set lower than the UVL setting.
5. Press the PROT key once. Rotate the voltage knob until the DC VOLTS display indicates UVP.LV. Rotate the current knob and reset the UVL level of the unit to its minimum setting. Press the current knob to accept the setting.

### Constant Current Check

1. Turn the POWER switch off. Wait a few seconds until the AC indicator on the front panel goes out.
2. Before handling the output terminals, measure the output voltage with an independent voltmeter to ensure that no dangerous voltage is present. **See additional connection warnings.**
3. Use a heavy wire and short the +V and -V output terminals together.
4. Turn the POWER switch on.
5. Turn the output on by pressing the OUT ON key. The green OUT indicator should be illuminated. The CC indicator should also be illuminated. If the CV indicator is illuminated, rotate the voltage knob on the left until the CC indicator becomes illuminated.
6. Rotate the current knob on the right while observing the DC AMPS display. The output current should vary while the knob is turned. The current range is from zero to the maximum rated output for the power supply model.

## Programming the Output

### Set the Output Voltage

### Set the Output Current

### Set the Output Power

### Enable the Output

The DP5700 series power supplies have three basic operating modes: constant voltage, constant current, and constant power mode. The mode in which the power supply operates at any given time depends on the voltage setting, current limit setting, the constant power setting, and the load resistance.

**In constant voltage mode**, the CV status indicator is on. The output voltage of the power supply is being regulated, or held constant at its voltage setting while the load current varies as required by the load. When the output current or output power reaches the current or power limit setting, the power supply will automatically switch (or cross over) to constant current (CC) or constant power (CP) mode. The output voltage is no longer held constant, and will sink to a value according to Ohm's law.

**In constant current mode**, the CV status indicator is on. The output current is being regulated, or held constant at its setting while the load voltage varies as required by the load. When the output voltage reaches the voltage limit setting, the power supply will automatically switch (or cross over) to CV mode. If, however, the power consumption reaches the power limit setting, the power supply will switch to power limit (CP) mode, where  $V_{out} \times I_{out} = P_{limit}$ .

**In constant power mode**, the CP status indicator is on. The output power is limited at either the power supply's maximum rated power, or the specified power limit setting. The power limit function restricts either the output voltage or output current to maintain the power limit at its designated setting.

## Set the Output Voltage

You can set the output voltage when the output is either disabled (OFF) or enabled (ON). When enabled, the output voltage will rise to the programmed setting. This assumes that a minimum output current has been programmed, that the output has not reached its current limit, or its power limit boundary.

**NOTE**

If you cannot adjust the voltage to the value that you desire, the power supply may be operating at its current limit. The maximum and minimum setting values of the output voltage are also limited by the over-voltage protection and under-voltage limit settings.

Front Panel Menu	SCPI Command
<p>With the output enabled, simply turn the Voltage knob to set the output voltage.</p> <p>Alternatively, if you do not want the voltage to change immediately, press the <b>PREV</b> key and turn the Voltage knob to the desired value. Press the Voltage knob to select the value. Press <b>PREV</b> again to exit the preview menu.</p> <p>With the output disabled, press the <b>PREV</b> key and turn the Voltage knob to the desired value. Press the Voltage knob to select the value. Press <b>PREV</b> again to exit the preview menu.</p>	<p>To set the output voltage to 100 volts: <b>VOLT 100</b></p>

The voltage knob can be set to coarse or fine resolution. Press the FINE button to select finer resolution. The FINE indicator turns on.

## Set the Output Current

You can set the output current when the output is either disabled (OFF) or enabled (ON). When enabled, the output current will be limited at its programmed setting.

Front Panel Menu	SCPI Command
<p>With the output enabled, simply turn the Current knob to set the output current.</p> <p>Alternatively, if you do not want the current to change immediately, press the <b>PREV</b> key and turn the Current knob to the desired value. Press the Current knob to select the value. Press <b>PREV</b> again to exit the preview menu.</p> <p>With the output disabled, press the <b>PREV</b> key and turn the Current knob to the desired value. Press the Current knob to select the value. Press <b>PREV</b> again to exit the preview menu.</p>	<p>To set the output current to 10 amps: <b>CURR 10</b></p>

The current knob can be set to coarse or fine resolution. Press the FINE button to select finer resolution. The FINE indicator turns on.

## Set the Output Power

A constant power limit is user settable, and the constant power limit will be maintained as long as the output voltage and current remain within their programmed limits.

You can set the output power limit when the output is either disabled (OFF) or enabled (ON). When enabled, the output power will be limited at its programmed setting. The power rating of the instrument is always enforced as the maximum power limit. While the power limit is engaged the front panel CP annunciator will be displayed. Additional information about the constant power limit function can be found under **Constant Power Limit** later in this chapter.

Front Panel Menu	SCPI Command
Press the <b>CONF</b> key and turn the Voltage knob to scroll to the C.PWR menu. Then select ON.	To turn the programmed power limit setting on or off: <b>POW:STAT ON OFF</b>
Scroll to the POWER menu and turn the Current knob to select a power limit value. Press the Current knob to enter the value. Press <b>CONF</b> again to exit the configuration menu.	To set the Power limit to 1 kW: <b>POW 1000</b>

## Enable the Output

### WARNING

Many models generate voltages above 60 VDC, with some models rated at up to 1,500 VDC! Ensure that all instrument connections, load wiring, and load connections are insulated or covered so that no accidental contact with lethal voltages can occur.

The OUT button can be pressed at any time (except in the Front Panel Lock mode, LLO mode, or when a Fault condition exists).

Front Panel Menu	SCPI Command
Press the <b>OUT</b> key. to enable the output.  The OUT status indicator illuminates when the output is on. If it blinks red, an alarm has occurred	To turn the output on or off: <b>OUTP ON OFF</b>

When the output is disabled, the output voltage and current fall to zero, the display shows OUT OFF. Press the OUT key to recover from faults such as: OVP, UVP, and FOLD faults after the fault conditions have been removed.

## Protection Functions

### Set the Over-Voltage Protection

### Set the Under-Voltage Protection

### Set the Over-Current Protection

### Additional Protections

### Protection Clear

The Keysight DP5700 series power supplies have many protection functions. A front panel status indicator will turn on when a protection function has been set. Most protection functions are latching, which means that they must be cleared once they have been set. Of the following protection functions, only the OV and OC are user-programmable.

<b>OVP</b>	Over-voltage protection is a hardware OVP whose trip level is a user-programmable value. The OVP is always enabled.
<b>UVP</b>	Under-voltage protection prevents adjustment of the output voltage below a specified under-voltage limit.
<b>OCP</b>	Over-current protection is a user-programmable function that can be enabled or disabled. When enabled, the output will be disabled when the output current reaches the current limit setting.
<b>OCL</b>	Over-current limit lets you limit the analog programming of a maximum current value.
<b>OTP</b>	Over-temperature protection monitors the internal temperature of the power supply and disables the output if the temperature exceeds the factory-defined limit. The OT protection is always enabled.
<b>AC FAIL</b>	AC fail indicates that a low voltage condition on the AC mains, or a power failure has occurred and has disabled the output. The AC fail protection is always enabled.

### Set the Over-Voltage Protection

Over-voltage protection protects against overvoltage conditions on the output. If the output voltage attempts to exceed the programmed limit in response to an analog programming signal or in the event of a power supply failure, the overvoltage protection circuit will protect the load by disabling the output. The OVP circuit monitors the voltage at the + and – sense terminals if remote sensing is selected, or at the output terminals if local sensing is selected.(see **Output Voltage Sensing**).

The OVP settings are limited at the minimum level to approximately 5% above the output voltage setting. Attempting to adjust the OVP below this limit will result in no response to the adjustment attempt. Refer to the **Supplemental Characteristics** for the maximum OVP settings.

Front Panel Menu	SCPI Command
Press the <b>PROT</b> key. With the output enabled or disabled, simply turn the Current knob to set the over-voltage protection.	To set the OVP level to 55 volts: <b>VOLT:PROT 55</b>
Press the Current knob to enter the value. Press <b>PROT</b> again to exit the protection menu.	

Upon detection of an over-voltage condition, the output is disabled, the display shows OVP FAULT, the red alarm indicator on the OUT key blinks, and OVP is set in the Questionable Condition status register.

Use one of the following methods to reset the OVP circuit after it activates. If the condition that caused the over-voltage shutdown is still present, the OVP circuit will turn the output off again.

1. Press the OUT key to turn the output on.
2. Turn the AC power off, wait a few seconds, and turn it on.
3. Turn the output off, then on again using the analog control (Interlock/Enable).
4. If the OVP continues to trip, try lowering the output voltage below the OVP setting, or raising the OVP setting.
5. Ensure that the load and the sense wiring is connected properly.

## Set the Under-Voltage Protection

The under-voltage protection prevents adjustment of the output voltage *below* a specified under-voltage limit, either from the front panel or remote interface. The combination of UVP and OVP lets you create a protection window for sensitive load circuitry.

The UVP settings are limited at the maximum level to approximately 5% below the output voltage setting. Attempting to adjust the UVP above this limit will result in no response to the adjustment attempt. The minimum UVP setting is zero. Refer to the [Supplemental Characteristics](#) for the maximum UVP settings.

Front Panel Menu	SCPI Command
Press the <b>PROT</b> key. With the output enabled or disabled, turn the Voltage knob and scroll to the UVP.LV menu. Turn the Current knob to select an under-voltage level. Press the Current knob to enter the value.	To set the UVP level to 5 volts: <b>VOLT:PROT:LOW 5</b>
Turn the Voltage knob and scroll to the UVP.EN menu. Turn the Current knob to select ON. Press the Current knob to enter the selection.	To enable the UVP protection: <b>VOLT:PROT:LOW:STAT ON</b>
Turn the Voltage knob and scroll to the UVP.DL menu. Turn the Current knob to select a UVP delay time. Press the Current knob to enter the value. Press <b>PROT</b> again to exit the protection menu.	To set the UVP delay to 0.1 second : <b>VOLT:PROT:LOW:DEL 0.1</b>

When the UVP is activated, the output is disabled. The display shows UVP FAULT, the red alarm indicator on the OUT key blinks, and UVP is set in the Questionable Condition status register.

Use one of the following methods to reset the UVP circuit after it activates. If the condition that caused the over-voltage shutdown is still present, the OVP circuit will turn the output off again.

1. Press the OUT key to turn the output on.
2. Turn the AC power off, wait a few seconds, and turn it on.

### 3 Using the Power Supply Locally

3. Turn the output off, then on again using the analog control (Interlock/Enable).
4. If the UVP continues to trip, try reducing the load, which may have caused the power supply to enter CC mode causing the voltage to drop.
5. Try increasing the current limit setting, which may have caused the power supply to enter CC mode causing the voltage to drop.

### Set the Over-Current Protection

When over-current protection is enabled, the power supply turns off the output if the output current reaches the current limit setting and transitions from CV to CC mode. This protection is useful when the load is sensitive to an over-current condition.

You can also specify an OCP delay to prevent momentary output settings, load, and status changes from tripping the over-current protection. In most cases these momentary conditions would not be considered an over-current protection fault, and having an OCP condition disable the output when they occur would be a nuisance. Specifying an OCP delay lets the OCP circuit ignore these momentary changes during the specified delay period. Once the OCP delay time has expired and the over-current condition persists, the output will shut down.

Front Panel Menu	SCPI Command
Press the <b>PROT</b> key Turn the Voltage knob and scroll to the OCP menu Turn the Current knob to select ON Press the Current knob to enter the selection.	To enable OCP: <b>CURR:PROT:STAT ON</b>
Turn the Voltage knob and scroll to the OCP.DL menu. Turn the Current knob to select a OCP delay time. Press the Current knob to enter the value. Press <b>PROT</b> again to exit the protection menu.	To specify a 10 millisecond delay: <b>CURR:PROT:DEL 0.01</b>

When the OCP is activated, the output is disabled. The display shows OCP FAULT, the red alarm indicator on the OUT key blinks, and OCP is set in the Questionable Condition status register.

Some factors that influence the time it takes the output to go into CC mode include:

- The difference in magnitude of the over-current condition compared to the current limit setting.
- If the over-current is only slightly greater than the current limit setting, it may take several tens of milliseconds for the output to transition to CC status.

## Additional Protections

### OCL - Analog over-current protection

The Over-Current Limit (OCL) protection lets you limit the maximum allowable current that can be programmed by the external analog input. Setting the OCL protection to ON (located in the PROT menu) clamps the maximum current programming value to the current setting that has previously been programmed from either the front panel or the corresponding SCPI command. This prevents the output from generating excessive currents when using the external analog programming port.

Front Panel Menu	SCPI Command
Press the <b>PROT</b> key Turn the Voltage knob and scroll to the OCL menu Turn the Current knob to select ON Press the Current knob to enter the selection.	To enable OCL: <b>CURR:ANALOG:LIM:STAT ON</b>

### OTP - Over-temperature protection

The OTP circuit shuts down the power supply before the internal components can exceed their safe internal operating temperature. When an OTP shutdown occurs, the display shows OTP FAULT, the red alarm indicator on the OUT key blinks, and OTP is set in the Questionable Condition status register.

### AC FAIL - AC power failure

The AC Fail alarm indicates whether the AC input has been shut down or AC input is incorrect. When any of these faults occur, the display shows AC FAULT, Output power is disabled, the red alarm indicator on the OUT key blinks, and AC is set in the Questionable Condition status register.

### Protection Clear

If an over-voltage, over-current, over-temperature, power-fail condition, or primary/secondary protection occurs, the output is disabled. The appropriate operating status indicator on the front panel will be on. To clear the protection function and restore normal operation, first remove that condition that caused the protection fault. Then, clear the protection function as follows:

Front Panel Menu	SCPI Command
Press the <b>PROT</b> key. Turn the Voltage knob and scroll to the PROT menu. Press the Current knob to clear the protection.	To clear a protection fault: <b>OUTP:PROT:CLE</b>

## External Control Signal Programming

### Analog Programming of Voltage and Current

### Analog Monitoring of Voltage and Current

### Analog Overcurrent Limit

### Interlock Function

### Output Enable/Disable

### Monitoring Output Status

### Monitoring CV/CC Status

### Auxiliary Signals Prog\_out\_1 and Prog\_out\_2

### Daisy Chained Output Shutdown

The rear panel **J1 connector** lets you program the power supply output voltage and current with an analog device. J1 also provides monitoring signals for output voltage and output current. The programming range and monitoring signals range can be selected between 0-5 V or 0-10 V using the Front Panel menu or SCPI command.

## Analog Programming of Voltage and Current

Analog Select (pin J1-6) accepts a voltage or dry contact input (referenced to J1-11) to enable analog programming of output voltage and current.

J1-6	Control of output current and voltage
2 – 30 V or Open	Digital (SCPI or front panel)
0 – 0.6 V or Short	Selected by CURR:ANALOG:SOURCE and VOLT:ANALOG:SOURCE

In Digital mode, the output voltage and current can be programmed via the front panel Voltage and Current knobs or via the SCPI commands. In Analog mode, the output voltage and current can be programmed by analog voltages or external resistors connected to the J1 contact pins. Refer to the following Analog Programming Connections figures for details.

## Analog Indicator

Signal Analog Indicator (pin J1-5) is an open collector output that indicates if the power supply is in Local programming mode or in Analog programming mode. To use this output, connect a pull-up resistor to a voltage source of 30 Vdc maximum. Choose the pull-up resistor so that the sink current is less than 10mA when the output is in low state. The J1-5 signal is low if the J1-6 input is low and at least one of the Analog control modes is selected.

## Analog Programming Connections

The following figures describe the rear panel connections for both voltage programming and resistance programming. In these figures, both voltage and current are programmed using the analog controls. However, you can choose to program only one parameter using Analog control, and the other parameter using Local control.

When voltage programming from J1, use a programming source with floated outputs to maintain the isolation of the power supply. To limit the maximum remote (analog) programming value of the current programming channel, refer to **OCL – Analog Programming Over-Current Limit**.

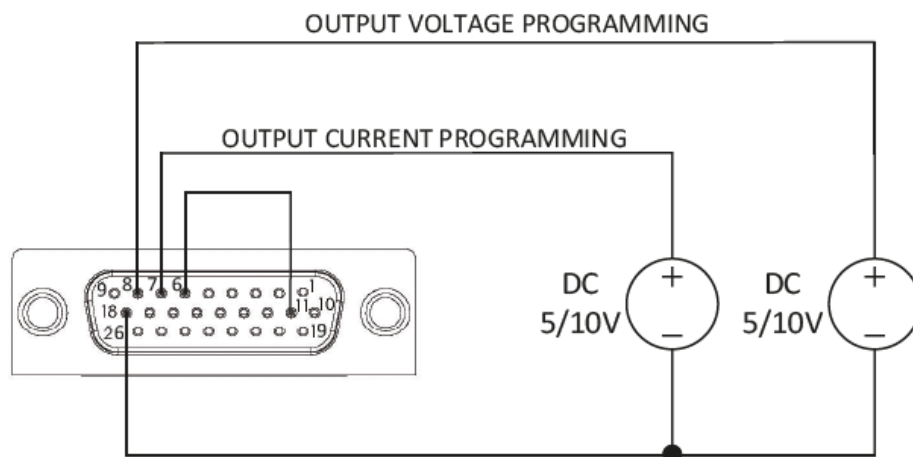

For resistive programming, the internal current sources for output voltage/current control supply 1mA of current through external programming resistors connected between J1-8 and J1-18, and between J1-7 and J1-18. The resulting voltage across the programming resistors is used as the programming voltage for the power supply. Resistances of 0~5 k $\Omega$  or 0~10 k $\Omega$  can be selected to program the output voltage and current from zero to full scale. Using variable resistors can control the output over the entire range. A combination of variable resistors and series/parallel resistors can control the output over a restricted portion of the range.

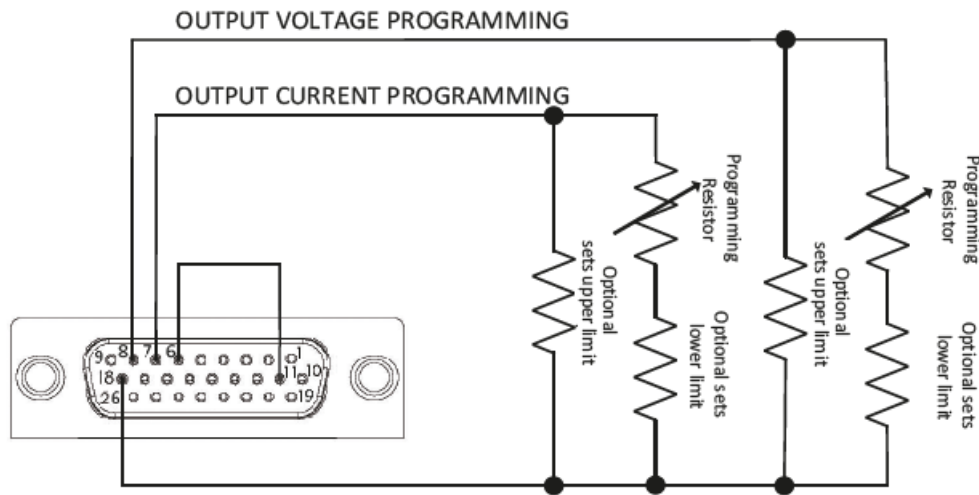

### Analog Programming Setup

After completing the Analog programming connections, configure the Analog programming pins using the front panel as follows:

Front Panel Menu	SCPI Command
<p>Press the <b>CONF</b> key. Turn the Voltage knob until either V.SRC or C.SRC appears on the display.</p> <p>Turn the Current knob to select either E.VOL or E.RES. Press the Current knob to make the selection.</p> <p>Turn the Voltage knob until RANGE appears.</p> <p>Turn the Current knob to select either 5 or 10. (5 V or 10 V for voltage programming; 5 kΩ or 10 kΩ for resistance programming.) Press the Current knob to make the selection.</p> <p>Press <b>CONF</b> again to exit the configuration menu.</p>	<p>CURR:ANALOG:SOURCE  VOLT:ANALOG:SOURCE  ANALOG:RANGE</p>

### Analog Monitoring of Voltage and Current

The J1 connector, located on the rear panel, provides analog signals for monitoring the output voltage and output current. Connections are made on pins .... **add pins** .... Selection of the voltage range between 0-5 V or between 0-10 V is made via the Front Panel or communication. The monitoring signals represent 0 to 100% of the power supply output voltage and output current. The monitor outputs have 500Ω series output resistance.

**NOTE** Ensure that the sensing circuit has an input resistance of greater than 500 kΩ or accuracy will be reduced.

The signal range (5 V or 10 V) of the analog monitoring pins is controlled by the same setting used for the analog programming pins above.

## Analog Overcurrent Limit

Analog Programming Over-Current Limit (OCL) function provides the ability to limit analog programming of maximum current programming value. Setting OCL to ON state clamps maximum current programming value to digital programming value (set by Front Panel or communication).

Setting OCL to OFF state (default configuration) provides the ability to program current setting according to power supply rated current value (up to about 108% of rated current).

Press the PROT key and scroll to OCL in the front panel menus, or use SCPI to enable/disable OCL via CURR:ANALOG:LIM:STATE OFF|ON.

## Interlock Function

You can use this function to enable or disable the output using an emergency shutoff or door-open switch.

### CAUTION

**Equipment Damage** To prevent possible damage to the unit, do not connect any of the Enable/Disable inputs to the positive or negative output terminals.

Signal ILC (pin J1-19) serves as power supply output enable control using a switch or relay. It is an isolated signal from the power supply output. You can use this function to enable or disable the output as emergency shutoff or door open switch. Connections to the signal are made on pin J1-19 (ILC) and on pin J1-11 (COM).

The ILC function can be enabled or disabled using the Front panel or SCPI command as follows

Front Panel Menu	SCPI Command
Press the <b>SYST</b> key. Turn the Voltage knob until ILC OFF appears. Turn the Current knob to select either ILC OFF or ILC ON. Press the Current knob to make the selection. Press <b>SYST</b> again to exit the configuration menu.	To enable or disable the interlock (ILC) function: <b>OUTP:INT ON OFF</b>

The signal definitions are as follows:

ILC Setting	ILC Input	Output	Display	Alarm LED
OFF (default)	Open or Short	On	Voltage/Current	Off
ON	Open or 2 V to 30 V	Off	ILC FAULT	red LED Blinking
	Short or 0 V to 0.0.6 V	On	Voltage/Current	Off

After the ILC condition has been removed, the output remains off until it is turned on via SCPI or the front panel

## Output Enable/Disable

**CAUTION**

**Equipment Damage** To prevent possible damage to the unit, do not connect any of the Enable/Disable inputs to the positive or negative output terminals.

The Enable (ENA\_IN) signal serves as power supply output enable control. Connection to the signal is made via pin J1-10 (ENA\_IN) and pin J1-11 (COM), which are isolated from the power supply output.

The ENA function can be enabled or disabled using the Front panel or SCPI command. Additionally, you can also select the ENA\_IN signal polarity as follows:

Front Panel Menu	SCPI Command
Press the <b>SYST</b> key. Turn the Voltage knob until ENA appears.	To enable the output enable signal: <b>OUTPut:INHIBit:MODE LATCHing OFF</b>
Turn the Current knob to select either ENA OFF or ENA ON. Press the Current knob to make the selection.	To specify polarity for the output enable signal: <b>DIGital:PIN10:POLarity POSitive NEGative</b>
Turn the Voltage knob and scroll to the ENA.PL menu. Turn the Current knob to select either REVERSE or NORMAl polarity. Press the Current knob to enter the selection.	
Press <b>SYST</b> again to exit the system menu.	

The signal definitions are as follows:

ENA Setting	ENA Input	ENA Polarity	Output	Display	Alarm LED
OFF (default)	Open or Short	N/A	On	Voltage/Current	Off
ON	Open or 2 V to 30 V	Normal	Off	ENA FAULT	red LED Blinking
	Short or 0 V to 0.0.6 V	Normal	On	Voltage/Current	Off
	Open or 2 V to 30 V	Reverse	On	Voltage/Current	Off
	Short or 0 V to 0.0.6 V	Reverse	Off	ENA FAULT	red LED Blinking

After the ENA condition has been removed, the output remains off until it is turned on via SCPI or the front panel.

## Monitoring Output Status

The PS\_OK #1 (J1 pin 3) and PS\_OK #2 (J1 pin 2) signals indicate the power supply output state. These signals are referenced to COM (J1 pin 11).

These two signals differ in the following ways:

- They are opposite polarity.
- One is open collector.
- One indicates only fault conditions. The other also indicates output off.

PS_OK #1 (J1 pin 3)	
Condition	Signal Level
Output off (via SCPI or front panel), or fault condition: over-voltage under-voltage over-current over-temperature interlock or enable signal AC line failure	Open collector high, max voltage of 30 V.
No fault condition, output on	Low, maximum sink current of 10 mA.

PS_OK #2 (J1 pin 2)	
Condition	Signal Level
Fault condition: over-voltage under-voltage over-current over-temperature interlock or enable signal AC line failure	Low
No fault condition, output on or off	High (approx. 5 V)

## Monitoring CV/CC Status

Signal CV/CC (pin J1-4) indicates the power supply operation mode, either constant voltage, constant current, or constant power.

**CAUTION**

**Equipment Damage** Do not connect CV/CC signal to a voltage source higher than 30 VDC. Always connect CV/CC signal to the voltage source with a series resistor to limit the sink current to less than 10mA.

---

The CV/CC\_MON signal is an open collector output with a maximum voltage of 30 V at J1-4, referenced to COM at J1-11. When the power supply operates in constant voltage mode, constant power mode, or when the output is off, the CV/CC signal output is high. When the power supply operates in constant current mode, the CV/CC signal output is low (0-0.6 V), with a maximum 10mA sink current.

## Auxiliary Signals Prog\_out\_1 and Prog\_out\_2

The programmed signal Prog\_out\_1 (J1-21) and Prog\_out\_2 (J1-20) are open drain, with a maximum input voltage of 25 V, and a maximum sink current of 100 mA. Programmed signals can be controlled from the front panel. Selecting OFF will program a low output signal level (the internal FET conducts). Selecting ON will program a high output signal level (the internal FET does not conduct).

**CAUTION**

**Equipment Damage** Do not connect Prog\_out\_1 and Prog\_out\_2 to a voltage source higher than 25 V. Always connect Prog\_out\_1 and Prog\_out\_2 to the voltage source with a series resistor to limit the sink current to less than 100 mA.

---

Front Panel Menu	SCPI Command
Press the <b>SYST</b> key.	[SOURce:]DIGital:OUTPut:DATA
Turn the Voltage knob until PIN 1 OFF or PIN 2 OFF appears.	
Press the Current knob to select PIN 1 ON or PIN 1 OFF, PIN 2 ON or PIN 2 OFF. Press Current knob to accept.	
Press <b>SYST</b> again to exit the configuration menu.	

---

## Daisy-Chained Output Shutdown

It is possible to configure a multiple power supply system to shut down all the units when a fault condition occurs in one of the units.

If a fault occurs in one unit, its PS\_OK #2 signal is set low and its display will indicate the fault. The other units shut off with their displays indicating SO FAULT (shut-off fault). When the fault condition is cleared, all units will recover according to their Safe-Start or Auto-Restart settings.

The following figure shows three daisy-chained units; the same connection method can be used with additional units.

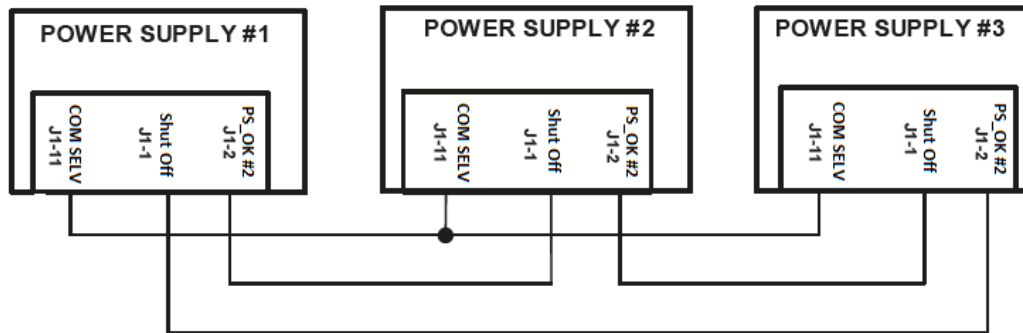

The Shut Off pin (J1-1) is edge-triggered and accepts 2 V to 25 V as the high level signal, 0 V to 0.6 V as the low level signal, or an open-short contact to enable or disable the power supply output.

After high to low transition is detected, the Shut Off input will disable the power supply output and the power supply will display SO FAULT (shut-off fault) on the voltage display.

The signal definitions are as follows:

Shut-Off signal level (J1-1 – J1-11)	Power supply output	PS_OK #2 (J1-2 – J1-11)	PS_OK #1 (J1-3 – J1-11)
2-30 V or Open	On	High	Low
0-0.6 V or Short	Off (SO.FAULT)	Low	High (open-collector)

## Parallel System Operation

Power supplies may be connected in parallel to form a primary/secondary system. See **Multiple Unit Connections**. The system is controlled and monitored via the primary unit. This includes programming and measurement of voltage, current, and power.

The current programmed and measured via the primary unit represents the total current of the paralleled system, and the same is true for power. Status readback from the primary unit represents the status of the entire system.

Secondary units will not accept the command form of most SCPI commands. For example, attempting to program voltage or current of a secondary unit will result in an error. Some SCPI queries are accepted by secondary units. For example, the individual output currents of the secondary units may be determined via measurement queries.

Front panel controls are disabled in secondary units.

SCPI commands associated with primary/secondary operation include:

**INSTRument:GROup:ACKnowledge**

**INSTRument:GROup:COUNT?**

**INSTRument:GROup:FUNCTION?**

Also note the PA and WSEC bits in the **Questionable status registers**.

## System Operations

### Instrument Triggering

### Internal Resistance

### Constant Power Limit

### Slew Rate Control

### Instrument Identification

### Instrument State Storage

### Front Panel Lockout

## Instrument Triggering

There are two types of output transients: List mode and Step mode. For details of their operation, see:

- Commands **VOLTage:MODE** and **CURRent:MODE**
- **Programming Output Lists**
- Commands **VOLTage:TRIGgered** and **CURRent:TRIGgered**

Both List and Step transients are triggered actions. To start a transient, it must first be initiated, and then triggered. To see how this process operates in List mode, see the flow chart under **Programming Output Lists**. For Step mode, the process is similar.

## Initiate

Commands that control initiation are:

- **INITiate[:TRANsient]**
- **INITiate:CONTinuous[:TRANsient]**
- **ABORt[:TRANsient]**

Note that the DP5700 series power supplies do not provide triggered measurements, and therefore **INITiate:ACQuire** and related commands are not supported.

### Trigger

There are three methods of triggering, selected by the **TRIGger[:TRANsient]:SOURce** command:

- BUS selects triggering via the programming interfaces (LAN, USB, or GPIB). The commands that can generate a trigger are:
  - **TRIGger[:TRANsient][:IMMediate]**
  - **\*TRG**
  - Group Execute Trigger (GET) (GPIB only).
- EXT selects triggering via the rear panel Trigger In signal (**J1 pin 22**). Note that because of internal design considerations, EXT triggering is available only for List mode, not for Step mode.
- IMM selects immediate triggering. This means that a trigger occurs as soon as the transient is initiated.

The behavior of the rear panel Trigger Out signal (**J1 pin 23**) is controlled by the **DIGital:PTRG:FUNction** command.

### Status Bits

Two bits in the **Operation Status register** are used to indicate the triggering status:

- When a transient (list or step) has been initiated, but not yet triggered, the *WTG-tran* bit (bit position 4) is set to 1. After a trigger, the bit returns to a value of 0.
- When a list has been triggered, the *tran active* bit (bit position 6) is set to 1 for the duration of the list. After the list has completed, the bit returns to a value of 0.

The front panel TRAN annunciator illuminates while the *WTG-tran* bit is set to 1, but only in List mode. Because of internal design considerations, the TRAN annunciator does not illuminate in Step mode.

## Internal Resistance

Internal resistance function is primarily used to simulate battery voltage drop, as a response to load current. In addition, it can be used in cases of voltage drop over long load wires.

Power supply output voltage  $V_{OUT}$  is set according to voltage setting minus actual load current multiplied by internal resistance value setting ( $V_{OUT}=V-I \times R_S$ ).

Internal resistance function is enabled via the **Front Panel Menu** or the communication command `VOLTage:RESistance:STATe <Bool>`.

Internal resistance setting range is from 0.001 to 1 ohm, in steps of 0.001 ohms. Internal resistance setting is available via the **Front Panel Menu** or the communication command `VOLTage:RESistance[:LEVel] <NRf+>`.

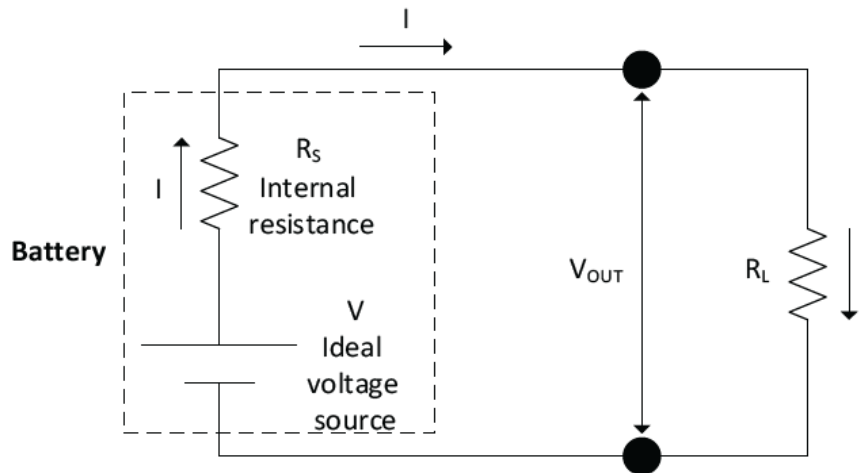

**Figure 5–7: Internal Resistance Circuit**

**NOTE**

If the Internal Resistance function is enabled, the List, Constant Power Limit, Slew-Rate, and Analog Programming functions are disabled.

**NOTE**

If the List, Constant Power Limit, Slew-Rate, or Analog Programming functions are enabled, the Internal Resistance function is disabled.

### Constant Power Limit

The Constant Power Limit function limits the output power provided by the power supply.

The Constant Power Limit function is enabled via the **Front Panel Menu** or the communication command [SOURce]:POWer:STATe <Bool>.

Constant power setting range is limited by multiplication of rated voltage by rated current, in steps of 1 watt. Constant power limit setting is available via the **Front Panel Menu** or the communication command [SOURce]:POWer[:LEVel] <NRf+>.

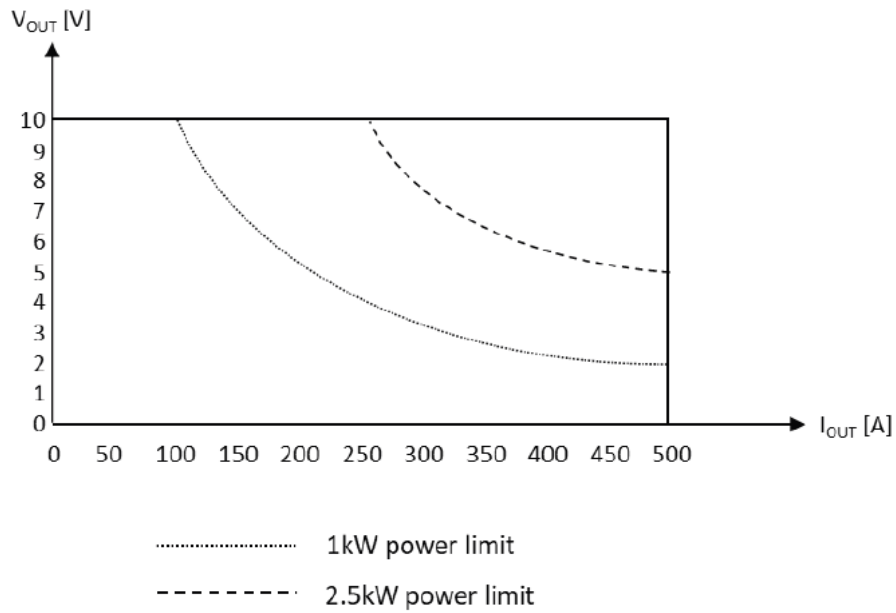
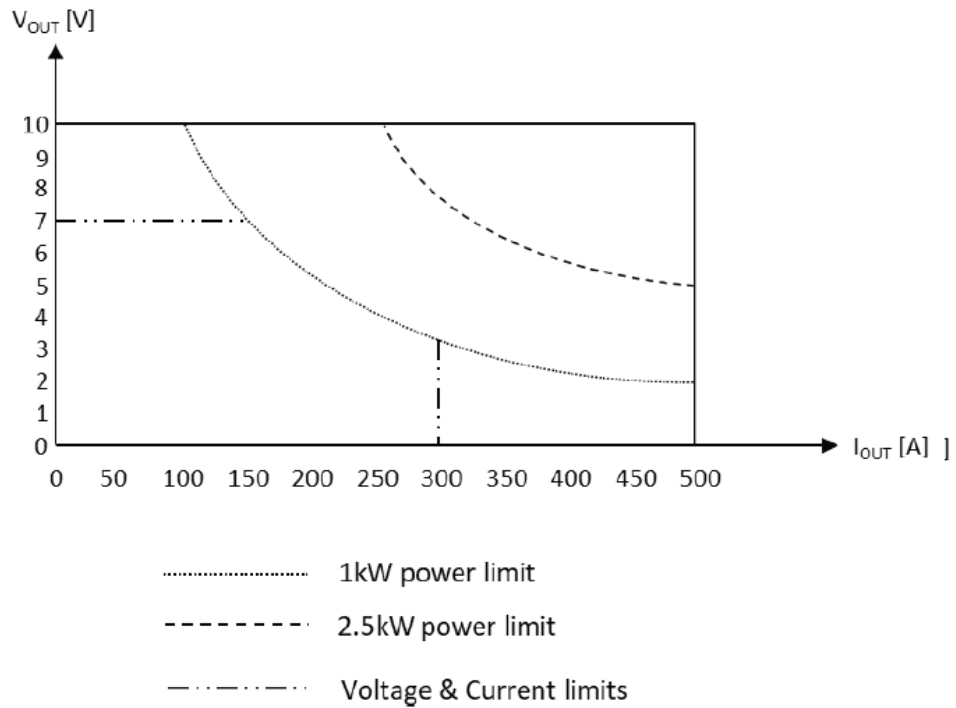

**Figure 5–8: Constant Power – Example 1**

**NOTE**

To achieve full constant power limit range, set the voltage and current settings to rated settings. Refer to Figure 5–8 as an example of 5 kW, 10 Volts, 500 Amperes power supply. Voltage setting is set to 10 Volts; current setting is set to 500 Amperes.

To limit voltage and current values (in addition to constant power limit), set voltage limit and current limit, as shown in Figure 5–9.



**Figure 5–9: Constant Power - Example 2**

## Slew-Rate Control

Slew-Rate control function provides the ability to control voltage or current reference slew rate.

Slew rate function is enabled via the Front Panel menu (refer to section 1.8) or the communication commands `SYSTem:SLEW[:STATe] <DSC>`.

- Select VOLT for voltage reference slew control
- Select CURR for current reference slew control
- Select OFF to disable slew-rate control function

Slew rate setting range is from 0.0001 to 999.99 Volts or Amperes per millisecond in steps of 0.0001 Volts or Amperes per millisecond. Slew rate settings are available via the **Front Panel Menu** or the following communication commands:

- `[SOURce]:CURRent:SLEW:DOWN <NRf+>` - Set current reference down programming slew.
- `[SOURce]:CURRent:SLEW:UP <NRf+>` - Set current reference up programming slew.
- `[SOURce]:VOLTage:SLEW:DOWN <NRf+>` - Set voltage reference down programming slew.
- `[SOURce]:VOLTage:SLEW:UP <NRf+>` - Set voltage reference up programming slew.

**NOTE**

Slew-Rate Control is active in Voltage/Current programming mode only. Slew-Rate Control does not affect OFF to ON or ON to OFF transitions.

---

**NOTE**

Maximum slew rate is limited by hardware.

---

**NOTE**

If the Slew-Rate function is enabled, the Internal Resistance, List, Constant Power Limit, and Analog Programming functions are disabled.

---

**NOTE**

If the Internal Resistance, List, Constant Power Limit, or Analog Programming functions are enabled, the Slew-Rate function is disabled.

---

## Instrument Identification

You can query the model number, serial number, options, and firmware revision. SCPI commands let you return information with the `*IDN?` and `*OPT?` queries.

Front Panel Menu	SCPI Command
not available	To return model number, serial number, and firmware revision: <code>*IDN?</code>
	To return the installed options: <code>*OPT?</code>

## Instrument State Storage

The power supply has ten storage locations in non-volatile memory to store instrument states. The locations are numbered 0 through 9. Any state previously stored in the same location will be overwritten.

Front Panel Menu	SCPI Command
Press the SYST key once. Rotate the Voltage knob until SAVE or RECAL appears.	To save a state in location 1: <b>*SAV 1</b>
Rotate the Current knob to select a location from 0 to 9. Press the Current knob to save or recall the state.	To recall a state from location 1: <b>*RCL 1</b>
Press SYST again to exit the menu.	

When shipped from the factory, the power supply is configured to automatically recall the reset (\*RST) settings at power-on. However, you can configure the power supply to recall the settings you have stored in memory location 0 (RCL0) at power-on.

Front Panel Menu	SCPI Command
Press the CONF key once. Rotate the Voltage knob until PWR.ON appears.	<b>OUTP:PON:STAT RCL0</b>
Rotate the Current knob to choose either RST or RCL 0. Press the Current knob to accept the setting.	
Press CONF again to exit the menu.	

## Front Panel Lock-Out

To lock and unlock the front panel controls, see the commands SYSTem:COMMunicate:RLState and SYSTem:KLOCK.

# 4

## Using the Power Supply Remotely

### Programming the Interfaces

### Programming Output Lists

### Introduction to the SCPI Language

This chapter contains information on how to configure the three remote interfaces that are provided on the back of the instrument. In most cases you can connect your power supply to any one of these interfaces and be up and running with a minimum amount of configuration.

**NOTE** Detailed information on configuring the remote interfaces is included in the documentation that you receive when you download the Keysight IO Libraries Suite, which is available at <http://www.keysight.com/find/iosuite>.

This chapter also contains a brief introduction to the SCPI Programming language. SCPI (Standard Commands for Programmable Instruments) is a programming language for controlling instrument functions over the GPIB. SCPI is layered on top of the hardware-portion of IEEE 488.2. The same SCPI commands and parameters control the same functions in different classes of instruments.

## Programming the Interfaces

### USB Configuration

### GPIB Configuration

### LAN Configuration

### Using the Web Interface

### Using Telnet

### Using Sockets

This instrument supports remote interface communication over three interfaces: GPIB, USB, and LAN. All three interfaces are "live" at power up. To use the interfaces, you must first install the Keysight IO Libraries software, found at [www.keysight.com/find/iolib](http://www.keysight.com/find/iolib).

The **front panel IO indicator** comes on whenever there is activity on the remote interfaces. The **front panel LAN indicator** comes on when the LAN port is connected and configured.

This instrument provides Ethernet connection monitoring. With Ethernet connection monitoring, the instrument's LAN port is continually monitored, and automatically reconfigured when the instrument is unplugged for a minimum of 20 seconds and then reconnected to a network.

## USB Configuration

There are no configurable USB parameters. You can retrieve the USB connect string using the Keysight Connection Expert that is installed with the IO Libraries.

## GPIB Configuration

Each device on the GPIB (IEEE-488) interface must have a unique address between 0 and 30. The instrument ships with the address set to 5. Your computer's GPIB interface card address must not conflict with any instrument on the interface bus.

This setting is non-volatile; it will not be changed by power cycling or \*RST. Use the front panel menu to change the GPIB address: Press the COMM key, and then navigate to the GPIB menu item.

## LAN Configuration

**NOTE**

For detailed information about LAN interface connections, refer to the documentation that you receive when you download the Keysight IO Libraries Suite.

---

The following steps will help you quickly get started connecting and configuring your instrument on a local area network (LAN). The two types of local area networks connections that are discussed in this section are site networks and private networks.

### Connecting to a Site LAN

A site LAN is a local area network in which LAN-enabled instruments and computers are connected to the network through routers, hubs, and/or switches. They are typically large, centrally-managed networks with services such as DHCP and DNS servers.

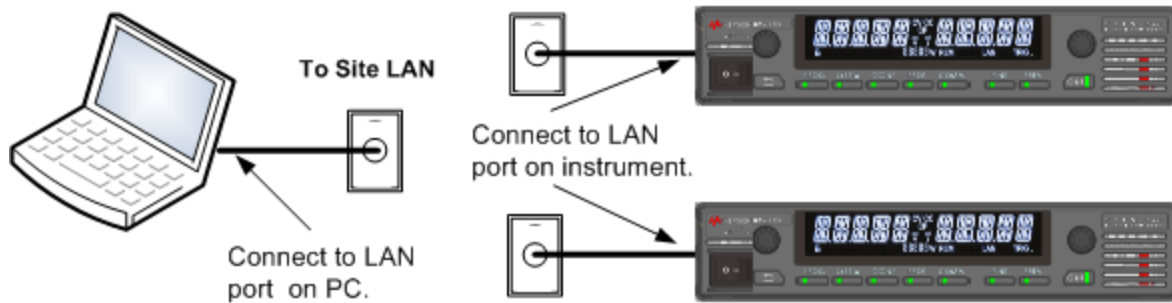

1. If you have not already done so, install the Keysight IO Libraries Suite.
2. Connect the instrument to the site LAN. Provided that your network has a DHCP server and uses DNS naming service, the instrument will automatically obtain an IP address from the network. This may take up to one minute. It will also register its hostname with the DNS server. The default hostname can then be used to communicate with the instrument.

The front panel LAN indicator will come on when the LAN port has been configured. If you are unable to communicate with the instrument, check that a valid IP address has been assigned. Press the front panel COMM key, and then navigate to the IP address.

#### NOTE

Each Keysight DP5700 power supply is shipped with a default hostname with the format: K-modelnumber-serialnumber, where modelnumber is the instrument's model number (e.g. DP5736A), and serialnumber is the last 5 digits of the serial number located on the label on the side of the unit. K-DP5736A-12345 is an example of a hostname.

3. Use the Connection Expert utility of the Keysight IO Libraries Suite to add the DP5700 power supply and verify a connection. To add the instrument, you can request the Connection Expert to discover the instrument. If the instrument cannot be found, you can add the instrument using the instrument's hostname.

#### NOTE

If this does not work, refer to the Troubleshooting sections in the Connection Expert utility that you received when you downloaded the IO Libraries Suite.

## 4 Using the Power Supply Remotely

4. You can now use Interactive IO within the Connection Expert to communicate with your instrument, or you can program your instrument using the various programming environments. You can also use the Web browser on your computer to communicate with the instrument as described under **Using the Web Interface** later in this chapter.

### Connecting to a Private LAN

A private LAN is a network in which LAN-enabled instruments and computers are directly connected, and not connected to a site LAN. They are typically small, with no centrally-managed resources.

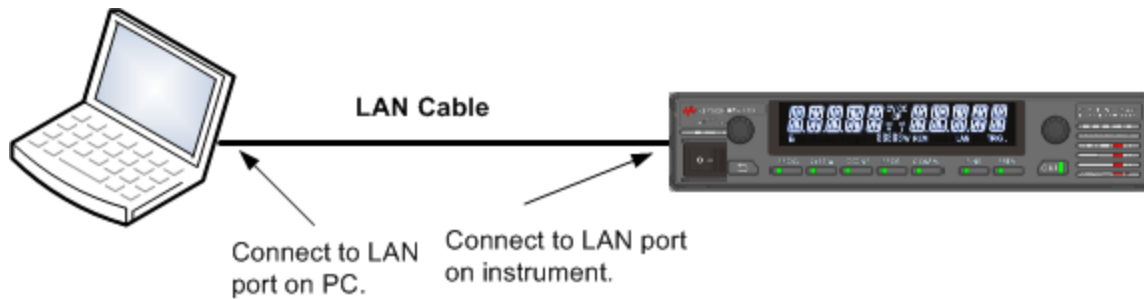

1. If you have not already done so, install the Keysight IO Libraries Suite.
2. Connect the instrument to the computer using a LAN cable. Alternatively, connect the computer and the instrument to a standalone hub or switch.
3. The factory-shipped instrument LAN settings are configured to automatically obtain an IP address from the network using a DHCP server, or using AutoIP if a DHCP server is not present. You can leave these settings as they are. Most Keysight products and most computers will automatically choose an IP address using auto-IP if a DHCP server is not present. Each assigns itself an IP address from the block 169.254.nnn. Note that this may take up to one minute.

The front panel LAN indicator will come on when the LAN port has been configured. If you are unable to communicate with the instrument, check that a valid IP address has been assigned. Press the front panel COMM key, and then navigate to the IP address.

4. Use the Connection Expert utility of the Keysight IO Libraries Suite to add the DP5700 power supply and verify a connection. To add the instrument, you can request the Connection Expert to discover the instrument. If the instrument cannot be found, you can add the instrument using the instrument's hostname. The default hostname is described under **Connecting to a Site LAN**.

#### NOTE

If this does not work, refer to the Troubleshooting sections in the Connection Expert utility that you received when you downloaded the IO Libraries Suite.

5. You can now use Interactive IO within the Connection Expert to communicate with your instrument, or you can program your instrument using the various programming environments. You can also use the Web browser on your computer to communicate with the instrument as described under [Using the Web Interface](#).

## Changing Lan Settings

To change LAN settings (for example, to assign a static IP address), use SCPI commands from the **SYSTem:COMMunicate:** group and the **LXI:** group. To use these commands before LAN communication has been established, you may send them via USB or GPIB.

## Resetting the LAN

A LAN reset will turn on DHCP, and set defaults for DNS configuration, mDNS state, and web password. These settings are optimized for connection to a site network. From the front panel, press the COMM key, and then navigate to LAN RESET. From SCPI, send **LXI:RESet**.

## Using the Web Interface

Your power supply has a built-in Web server that lets you control it directly from an internet browser on your computer.

The Web interface is enabled when shipped. To launch the Web interface:

1. Open the Web browser on your computer.
2. Enter the instrument's hostname or IP address into the browser's Address field. The home page will appear.
3. Various options are available on the home page, including Control Instrument and Configure LAN. If prompted for a password, the default password is **keysight**. If the password has been changed and is forgotten, the default may be restored by performing a LAN reset on the front panel. Press the COMM key, and then navigate to LAN RESET.

## Using Telnet

In a Command Prompt box type: telnet hostname 5024 where hostname is the instrument's hostname or IP address, and 5024 is the instrument's telnet port.

You should get a Telnet session box with a title indicating that you are connected to the power supply. Type the SCPI commands at the prompt.

### Using Sockets

**NOTE**

Power supplies allow any combination of up to six simultaneous data socket, control socket, and telnet connections to be made.

---

Keysight instruments have standardized on using port 5025 for SCPI socket services. A data socket on this port can be used to send and receive ASCII/SCPI commands, queries, and query responses. All commands must be terminated with a new line for the message to be parsed. All query responses will also be terminated with a new line.

The socket programming interface also allows a control socket connection. The control socket can be used by a client to send device clear and to receive service requests. Unlike the data socket, which uses a fixed port number, the port number for a control socket varies and must be obtained by sending the following SCPI query to the data socket: **SYSTEM:COMMunicate:TCPIP:CONTRol?**

After the port number is obtained, a control socket connection can be opened. As with the data socket, all commands to the control socket must be terminated with a new line, and all query responses returned on the control socket will be terminated with a new line.

To send a Device Clear, send the string "DCL" to the control socket. When the power supply has finished performing the Device Clear it echoes the string "DCL" back to the control socket.

Service requests are enabled for control sockets using the Service Request Enable register. Once service requests have been enabled, the client program listens on the control connection. When SRQ goes true the instrument will send the string "SRQ +nn" to the client. The "nn" is the status byte value, which the client can use to determine the source of the service request.

## Programming Output Lists

### Program the List Levels

### Program the List Dwell Times

### Specify the List Pacing

### Program the List Generated Trigger Signals

### Specify the List Repeat Count

**NOTE**

List operation cannot be programmed from the front panel, only via SCPI commands. Lists cannot be used together with Slew-Rate control, Internal Resistance, or Constant Power Limit.

---

Lists let you generate complex sequences of output changes with rapid, precise timing, which may be synchronized with internal or external signals. In contrast to an output step, which is a one-time output change, an output list is a sequence of output changes. Lists can contain up to 100 individually programmed steps in increments as small as one millisecond, and can be programmed to repeat themselves. Only one parameter at a time, either voltage or current, may be controlled by a list.

The voltage and current lists are paced by a separate dwell list that defines the duration or dwell of each step. Each of the up to 100 steps can have a unique dwell time associated with it, which specifies the time in seconds that the list will remain at that step before moving on to the next step. Refer to **LIST:DWEL** for information about the dwell range and resolution.

Lists can also be trigger-paced, in which the list advances one step for each trigger received. This is useful if you need an output list to closely follow triggered events. With a trigger-paced list, triggers that are received during the dwell period are ignored. Refer to **LIST:DWEL** for additional information.

Lists can also generate trigger signals at the end of each list step or at the completion of the entire list. These trigger signals can be used to synchronize other events associated with the list. Refer to **LIST:STEP** for additional information.

All lists (voltage, current, and dwell) must be set to the same number of steps, otherwise an error occurs when the list is run. For convenience, a list may be programmed with only one step or value. In this case, a single-step list is treated as if it had the same number of steps as the other lists, with all values being equal to the one value.

List data is not saved as part of a saved instrument state.

## 4 Using the Power Supply Remotely

The following figure shows a simplified list model:

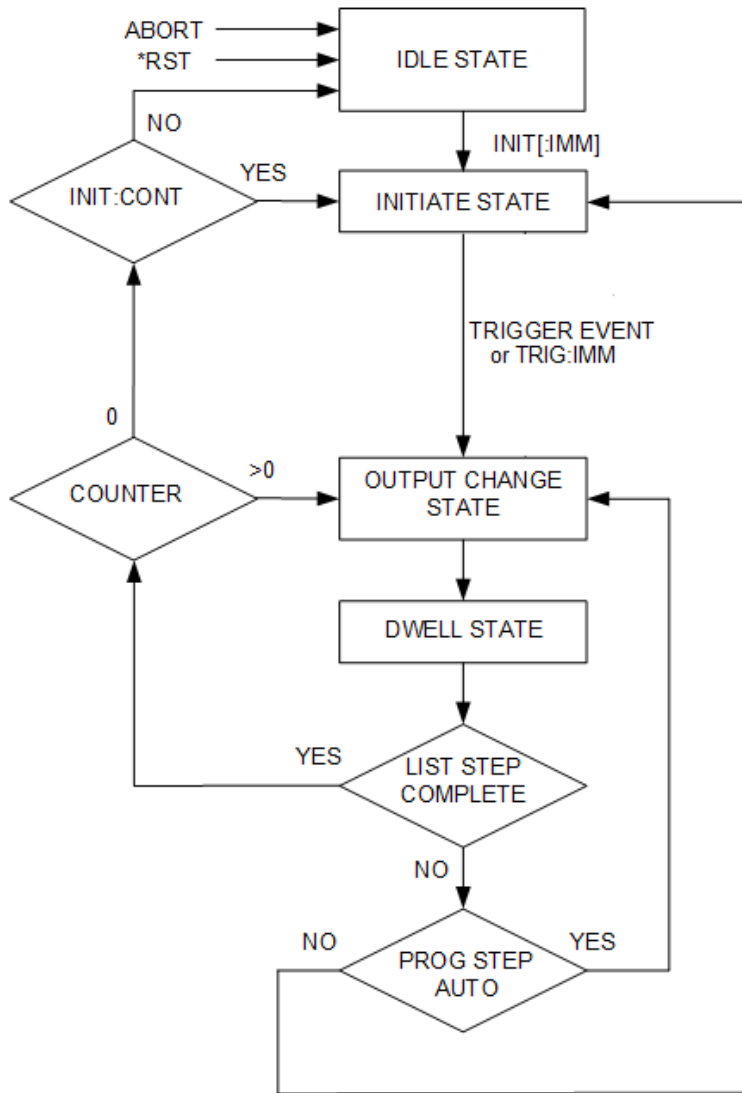

## Program the List Levels

**Example 1** If you are programming a voltage pulse or pulse train, set the amplitude of the pulse. For example, to generate a pulse with an amplitude of 15 V, program the amplitude for the pulse (step 0), and the amplitude for the off time (step 1).

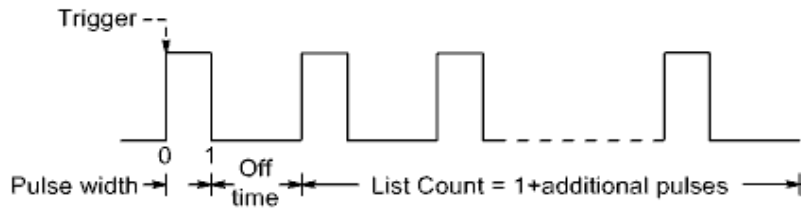

Front Panel	SCPI Command
Not available	To program the amplitude for step 0 (the pulse) and step 1 (the off time): <b>LIST:VOLT 15,0</b>
	To program a current limit for this list:

**Example 2** If you are programming an arbitrary voltage list, specify the amplitudes for the list. The order in which the values are entered determines the order in which the values will be output. To generate the voltage list shown in the figure, a list may include the following six values: 9, 0, 6, 0, 3, 0:

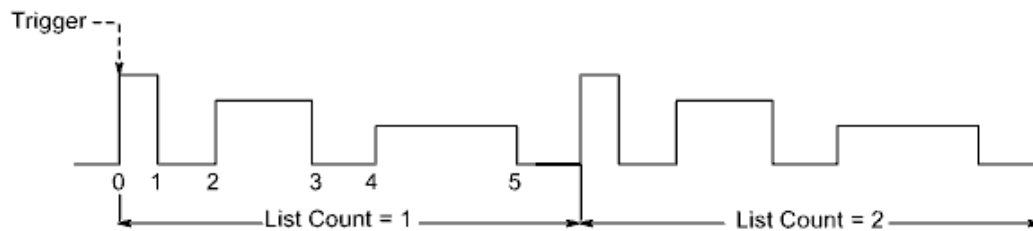

Front Panel	SCPI Command
Not available	To program a voltage list of 6 steps: <b>LIST:VOLT 9,0,6,0,3,0</b>
	To program a current limit for this list:

### NOTE

If a current list has only one value, that value will be applied to all steps in the list.

## Program the List Dwell Times

**Example 1** If you are programming a voltage pulse, set the dwell time or width of each pulse. Also specify the off time after each pulse. This is necessary if you are generating a pulse train, since the off time determines the time between pulses. To generate a pulse with a pulse width of 1 second and an off time of 2 seconds, use:

Front Panel	SCPI Command
Not available	To program the dwell for step 0 (the pulse) and step 1 (the off time): <b>LIST:DWEL 1,2</b>

You have now configured a single pulse. If you wish to generate a pulse train, simply specify the number of pulse repetitions as described under "Specify How Many Times the List Repeats".

**Example 2** If you are programming an arbitrary voltage list, specify the amplitudes for the list as previously described. The dwell values determine the time interval, in seconds, that the output remains at each step in the list before it advances to the next step. To specify the six dwell intervals in the figure, a list may include the following six values: 2, 3, 5, 3, 7, 3: Each dwell value follows the corresponding list step.

Front Panel	SCPI Command
Not available	To program a dwell of 6 values, use: <b>LIST:DWEL 2,3,5,3,7,3</b>

### NOTE

The number of dwell steps must equal the number of voltage steps. If a dwell list has only one value, that value will be applied to all steps in the list.

## Specify the List Pacing

You can specify if the list will be dwell or trigger-paced. The default selection is dwell-paced.

**AUTO** - In a dwell paced list, each step is assigned a dwell time. The dwell time determines the time that the output remains at the step. As each dwell time elapses, the next step is immediately output.

**ONCE** - In a trigger-paced list, the list advances one step for each trigger received. You can also a dwell period if you want to ignore triggers during the dwell time, or guarantee a minimum dwell time between triggered list steps.

Front Panel	SCPI Command
Not available	To set the list pacing to dwell-paced: <b>LIST:STEP AUTO</b>
	To set the list pacing to trigger-paced: <b>LIST:STEP ONCE</b>

## Program the List Generated Trigger Signals

You can generate trigger signals from the list that can be routed to other destinations. For example, you can use trigger signals to trigger actions on any external equipment connected to the digital port. See the command **DIGital:PTRG:FUNction**.

## Specify the List Repeat Count

You can specify how many times you want the list (or pulse) to repeat. At reset, the list count is set to 1 repetition. Sending the INFINITY parameter in the SCPI command makes the list repeat indefinitely.

Front Panel	SCPI Command
Not available	To program the list to run twice: <b>LIST:COUN 2</b>

When the list has completed, the output remains at the value of the last list step.

### Voltage List Example

The following figure illustrates the list commands. Note that only one parameter at a time, either voltage or current, may be controlled by a list. The other parameter can be set to a fixed limit.

The list ends with the voltage remaining at the last list step.

VOLT:MODE LIST	Select LIST Mode sequence
LIST:VOLT 2,4,2,8,5,4	Set voltage values "2,4,2,8,5,4" Volts
LIST:DWEL 0.5,0.5,1,1,1,1	Set dwell values "0.5,0.5,1,1,1,1" seconds
LIST:STEP AUTO	Set step execution mode to "AUTO"
LIST:COUN 1	Set list execution iterations to "1"
TRIG:SOUR BUS	Select BUS trigger source
INIT:CONT OFF	Enable Trigger system for a single trigger
INIT	Initialize trigger system
*TRG	Send the trigger

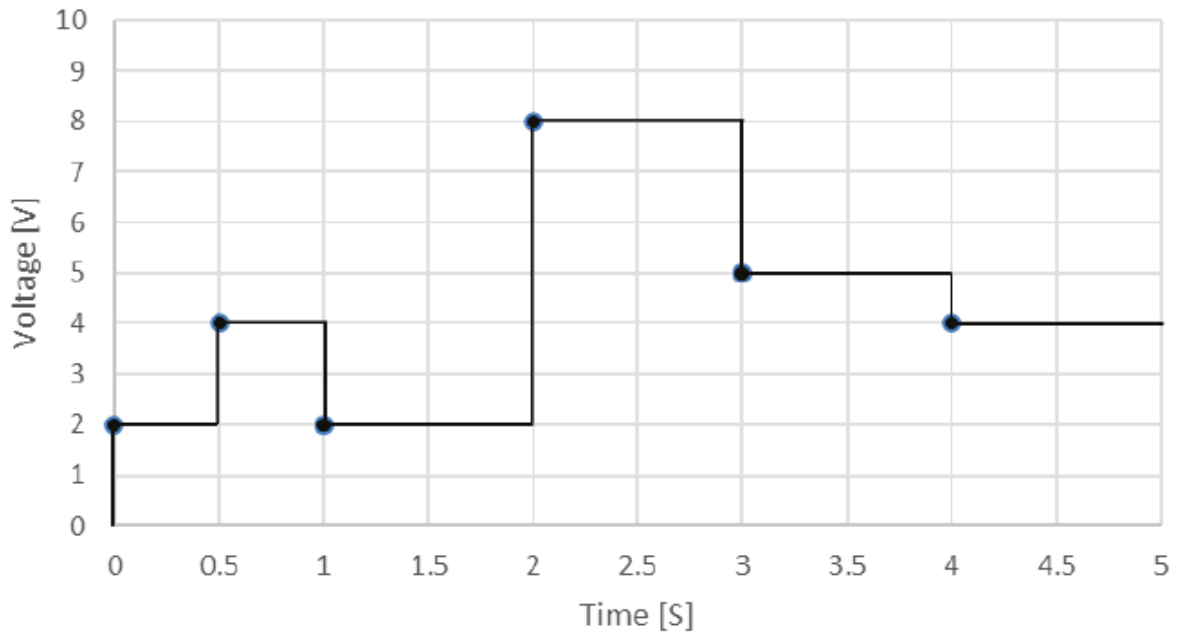

## Introduction to the SCPI Language

### Command Types

### Keywords

### Queries

### Command Separators and Terminators

### Syntax Conventions

### Parameter Types

### Device Clear

## Command Types

This instrument complies with the rules and conventions of the present SCPI version (see [SYSTem:VERSion?](#)).

SCPI (Standard Commands for Programmable Instruments) is an ASCII-based instrument command language designed for test and measurement instruments. SCPI has two types of commands, common and subsystem.

## Subsystem Commands

Subsystem commands perform specific instrument functions. They are comprised of alphabetically arranged commands that extend one or more levels below the root in a hierarchical structure, also known as a *tree system*. In this structure, associated commands are grouped together under a common node or root, thus forming *subsystems*. A portion of the OUTPut subsystem is shown below to illustrate the tree system. Note that some [optional] commands have been included for clarity.

```
OUTPut
  [:STATe] OFF|0|ON|1
  :PON
    :STATe RST|RCL0
  :PROTection
    :CLEar
```

## IEEE-488.2 Common Commands

The IEEE-488.2 standard defines a set of common commands that perform functions such as reset, self-test, and status operations. Common commands always begin with an asterisk (\*), are three characters in length, and may include one or more parameters. The command keyword is separated from the first parameter by a blank space. Use a semicolon (;) to separate multiple commands as shown below:

### Keywords

Keywords, also referred to as headers, are instructions recognized by the instrument. Common commands are also keywords.

OUTPut is the root keyword, PROTection is a second-level keyword, CLear is a third-level keyword. Colons ( : ) separate the keyword levels.

The command syntax shows most commands (and some parameters) as a mixture of upper- and lower-case letters. The upper-case letters indicate the abbreviated spelling for the command. For shorter program lines, you can send the abbreviated form. For better program readability, you can send the long form.

In the above examples, OUTP and OUTPUT are both acceptable forms. You can use upper- or lower-case letters. Therefore, OUTPUT, outp, and Outp are all acceptable. Other forms such as OUT, are not valid and will generate an error.

### Queries

Following a keyword with a question mark ( ? ) turns it into a query (Example: VOLTage?, VOLTage:TRIGgered?). If a query contains parameters, place the query indicator at the end of the last keyword, before the parameters. Insert a space between the query indicator and the first parameter.

You can query the programmed value of most parameters. For example, you can query the voltage setting by sending:

```
VOLTage?
```

You can also query the minimum or maximum allowable voltage settings as follows:

```
VOLTage? MIN  
VOLTage? MAX
```

You must read back all the results of a query before sending another command to the instrument. Otherwise, a *Query Interrupted* error will occur and the unreturned data will be lost.

### Command Separators and Terminators

#### Separators

Colons ( : ) separate keyword levels. Blank spaces must be used to separate command parameters from their corresponding keyword. Note the space between STATe and the \*RST parameter.

```
OUTPut:PON:STATe RST
```

Semicolons ( ; ) separate commands within the same subsystem. This lets you send several subsystem commands within the same message string. For example, sending the following command string:

```
OUTPut:STATe ON;PON:STATe RST
```

is the same as sending the following commands:

```
OUTPut ON
OUTPut:PON:STATe RST
```

Note that the semicolon follows the implied path of the hierarchical tree structure. In the above example, the optional :STATe keyword must follow the OUTput keyword to place the command parser at the second level in the hierarchy. This allows the use of the PON keyword after the semicolon, since PON is a second-level keyword.

You can also combine commands of different subsystems within the same message string. In this case, you must use a colon to return the command parser to the root level in order to access another subsystem. For example, you could clear the output protection and check the status of the Operation Condition register in one message by using a root specifier as follows:

```
OUTPut:PROTection:CLear;:STATus:OPERation:CONDition?
```

Note the use of the colon *after* the semicolon in order to return the command parser to the root.

## Terminators

A command string sent to the instrument must terminate with a new line (<NL>) character. The IEEE-488 EOI (End-Or-Identify) message is interpreted as a <NL> character and can be used to terminate a command string in place of an <NL>. A carriage return followed by a new line (<CR><NL>) is also accepted. Command string termination will always reset the current SCPI command path to the root level.

## Syntax Conventions

- **Triangle brackets** (< >) indicate that you must specify a value for the enclosed parameter. For example, in the VOLTage <value> command syntax, the <value> parameter is enclosed in triangle brackets. The brackets are not sent with the command string. You must specify a value for the parameter (Example: "VOLTage 50 V") unless you select another option shown in the syntax (Example: "VOLTage MAX").
- **A vertical bar** (|) separates multiple parameter choices for a given command string. For example, RST|RCL0 in the OUTPut:PON:STATe command indicates that you can specify "RST" or "RCL0". The bar is not sent with the command string.
- **Square brackets** ([ ]) enclose some syntax elements – nodes and parameters for example. This indicates that the element is optional and can be omitted. The brackets are not sent with the command string. Any keyword enclosed in brackets is optional and can be omitted. However, if you are combining several commands within the same message string as previously described, you must include the optional commands to place the command parser at the correct level in the hierarchy.

### Parameter Types

The SCPI language defines several data formats to be used in commands and queries.

#### Numeric Parameters

Commands that require numeric parameters will accept all commonly used decimal representations of numbers including optional signs, decimal points, and scientific notation. If a command accepts only certain specific values, the instrument will automatically round the input numeric parameters to the accepted values. The following command requires a numeric parameter for the voltage value:

```
[SOURce:]VOLTage 50 V|MIN|MAX
```

Note that special values for numeric parameters such as MINimum and MAXimum are also accepted. Instead of selecting a specific value for the voltage parameter, you can substitute MIN to set the voltage to its minimum allowable value, MAX to set it to its maximum allowable value.

You can also send engineering unit suffixes with numeric parameters (e.g., V for volts, A for amperes, W for Watts). All parameters values are in base units.

#### Discrete Parameters

Discrete parameters are used to program settings that have a limited number of values (like ONCe or AUTO). They may have a short form and a long form just like command keywords. You can use upper- or lower-case letters. Query responses will always return the short form in all upper-case letters. The following command requires a discrete parameter for the power-on state:

```
OUTPut:PON:STATe RST|AUTO
```

#### Boolean Parameters

Boolean parameters represent a single binary condition that is either true or false. For a false condition, the instrument will accept "OFF" or "0". For a true condition, the instrument will accept "ON" or "1". When you query a Boolean setting, the instrument will always return "0" or "1". The following command requires a Boolean parameter:

```
OUTPut OFF|0|ON|1
```

#### ASCII String Parameters

String parameters can contain virtually any set of ASCII characters. A string must begin and end with matching quotes, either with a single quote or a double quote. You can include the quote delimiter as part of the string by typing it twice without any characters in between. The following command uses a string parameter:

```
SYSTem:COMMunicate:LAN:IPAddress "192.168.1.42"
```

## Device Clear

Device Clear is an IEEE-488 low-level bus message that you can use to return the instrument to a responsive state. Different programming languages and IEEE-488 interface cards provide access to this capability through their own unique commands. The status registers, the error queue, and all configuration states are left unchanged when a message is received.

performs the following actions:

- If a measurement is in progress, it is aborted.
- The instrument returns to the trigger idle state.
- The instrument's input and output buffers are cleared.
- The instrument is prepared to accept a new command string.

**NOTE**

The ABORt command is the recommended method to terminate an instrument operation.

---



# 5

## SCPI Programming Reference

### Command Quick Reference

### Reset State (\*RST)

### SCPI Error Messages

This section provides the syntax and parameters for all the IEEE 488.2 SCPI Subsystem commands and Common commands used by the power supply. It is assumed that you are familiar with the **SCPI introductory** material in chapter 4, which explains the terms, symbols, and syntactical structures used here and gives an introduction to programming. You should also be familiar with chapter 3, in order to understand how the power supply functions.

## Command Quick Reference

The DP5700 power supplies are single-channel products. Some commands accept an optional channel list (clist). This has no effect, and is accepted only for compatibility with multi-channel power supplies. Only a value of 1 is accepted for the channel list. Any other value(s) will result in an error.

Some [optional] commands have been included for clarity. All settings commands have a corresponding query. See the [Syntax Conventions](#) for SCPI.

## Subsystem Commands

SCPI Command	Description
<b>ABORt</b> [:TRANsient]	Cancels any triggered actions.
<b>DISPlay</b> [:WINDow] [:STATe] 0 OFF 1 ON	Turns the front panel display on or off.
<b>IEEE-488 Common</b>	Common Commands
<b>INITiate</b> :CONTInuous[:TRANsient] 0 OFF 1 ON [:IMMEdiate][:TRANsient]	Continuously initiates the transient trigger system. Initiates the transient trigger system.
<b>INSTrument</b> :GROUP :ACKNowledge :COUNT? :FUNCTion?	Acknowledge a change in parallel assembly. Returns the total number of units in the configuration. Queries function of instrument in a primary/secondary configuration.
<b>LXI</b> :IDENtify[:STATe] 0 OFF 1 ON :MDNS[:STATe] 0 OFF 1 ON :MDNS:HNAME? :MDNS:SNAME? :RESet	Turns the front panel LXI Identify indicator on or off. Sets the LXI MDNS state on or off. Returns the instrument's mDNS host name. Returns the instrument's mDNS service name. Resets LAN settings to a known operating state.
<b>MEASure</b> [:SCALar] :CURRent [:DC]? :POWer [:DC]? :VOLTage [:DC]?	Takes a measurement; returns the averaged current. Takes a measurement; returns the averaged power. Takes a measurement; returns the averaged voltage.

SCPI Command	Description
<b>OUTPut</b>	
[:STATE] 0 OFF 1 ON	Enables or disables the output.
:INHibit:MODE LATChing OFF	
:INTerlock[:STATe] 0 OFF 1 ON	Enables or disables the ILC (interlock) function.
:OUTPut:DIGital:PIN10:POLarity POS NEG	This sets the polarity of the rear panel ENA signal.
:PON	
:STATe RST RCL0	Sets the output power-on state.
:PRELoad[:STATe] 0 OFF 1 ON	Enable continuous down-programming current
:PROTection	
:CLEar	Resets the latched protection.
[SOURce:]	Optional
<b>:ANALog</b>	
:RANGe 5 10	Sets the full-scale analog programming and monitor range.
<b>:CURRent</b>	
:MODE FIXed STEP LIST	Sets the transient mode.
[:LEVel]	
[:IMMediate][:AMPLitude] <curr>	Sets the output current.
:TRIGgered[:AMPLitude] <curr>	Sets the triggered output current.
:ANALog	
:LIMit:STATe 0 OFF 1 ON	Enables/disables digital current limit while in analog control mode.
:SOURce OFF VOLTage RESistance	Turns on/off and selects the type of analog programming.
:MODE FIXed LIST STEP	Sets the current mode.
:PROTection	
:DELay <delay>	Sets the over-current protection delay.
:STATe 0 OFF 1 ON	Enables or disables the over-current protection.
:SLEW	
:POSitive[:IMMediate] <slew>	Sets the positive current slew rate.
:NEGative[:IMMediate] <slew>	Sets the negative current slew rate.
<b>:DIGital</b>	
:OUTPut:DATA	Controls the digital output pins on rear panel connector J1.
:PIN<2 10>:FUNCTion	Compatibility only; does nothing.
:PIN10:POLarity POSitive NEGative	Accepts PIN3 as alias for PIN10
:PTRG:FUNCTion OFF FSTR TRIG	Sets the operation of the Trigger Out signal (J1 pin 23).

SCPI Command	Description
<b>:LIST</b>	
:COUNT <repeatcount>	Set list repeat count (1-9999, INF)
:CURRENT	
[:LEVEL] <curr> {,<curr ...>}	Sets the list of current points.
:POINTS?	Returns the number of current list points.
:DWEll <time> {,<time ...>}	Sets the list of dwell times.
:POINTS?	Returns the number of dwell list points.
:STEP ONCE AUTO,	Specifies if a trigger executes a step sequence or a single step.
:VOLTage	
[:LEVEL] <volt> {,<volt ...>}	Sets the list of voltage points.
:POINTS?	Returns the number of voltage list points.
<b>:VOLTage</b>	
:ANALog	
:SOURce OFF VOLTage RESistance	Turns on/off and selects the type of analog programming.
[:LEVEL] <volt>{,<volt ...>}	Sets the list voltage values.
[:IMMEDIATE][:AMPLitude] <volt>	Sets the output voltage.
:TRIGgered[:AMPLitude] <volt>	Sets the triggered output voltage.
:MODE FIXed LIST STEP	Sets the transient mode.
:PROTection	
[:LEVEL] <volt> MIN MAX	
:LOW	
[:LEVEL] <volt> MIN MAX	Sets the under-voltage protection level.
:DElay <time> MIN MAX	Sets the under-voltage protection delay time.
:STATe 0 OFF 1 ON	Enables or disables under-voltage protection.
:RESistance	
[:LEVEL]	
[:IMMEDIATE][:AMPLitude] <res>	Sets the output resistance level.
STATe 0 OFF 1 ON	Enables or disables output resistance.
:SENSe[:SOURce] LOCa REMOte	Selects local or remote voltage sensing.
:SLEW	
POSitive[:IMMEDIATE] <slew>	Sets the positive voltage slew rate.
:NEGative[:IMMEDIATE] <slew>	Sets the negative voltage slew rate.
<b>:POWER</b>	
[:LEVEL]	
[:IMMEDIATE][:AMPLitude] <pow>	Sets the output power.
:STATe 0 OFF 1 ON	Enables or disables the constant power controls.
<b>:SLEW</b>	
:FUNction NONE VOLTage CURRENT	Sets the slew function.

SCPI Command	Description
--------------	-------------

**STATus**

:OPERation	
:CONDition?	Queries the operation condition register.
:ENABle <value>	Sets the operation enable register.
[:EVENT]?	Queries the operation event register.
:NTRansition <value>	Sets the negative transition filter.
:PTRansition <value>	Sets the positive transition filter.
:PRESet	Presets all Enable, PTR, and NTR registers.
:QUEStionable	
:CONDition?	Queries the operation condition register.
:ENABle <value>	Sets the operation enable register.
[:EVENT]?	Queries the operation event register.
:NTRansition <value>	Sets the negative transition filter.
:PTRansition <value>	Sets the positive transition filter.
SUPPort:INFormation:ALL?	KIS utilization & health info

**SYSTem**

:COMMunicate	
:LAN CONTRol?	Returns the initial socket control connection port number.
:LAN TCPip:CONTRol?	Returns the initial socket control connection port number.
:LAN:DHCP 0 OFF 1 ON	Enables or disables the DHCP.
:LAN:DNS "<address>"	Assigns a DNS server when DHCP is disabled.
:LAN:DOMain "<name>"	Assigns a domain name when DHCP is disabled.
:LAN:GATEway "<address>"	Assigns a default gateway when DHCP is disabled.
:LAN:HOSTname "<name>"	Assigns a hostname to the instrument.
:LAN:IPADdress "<address>"	Sets a static IP address.
:LAN:MAC?	Returns the instrument's MAC address.
:LAN:SMASK "<mask>"	Sets a static subnet mask.
:RLState LOCal REMOte RWLock	Configures the remote/local state of the instrument.
:DATE <yyyy,mm,dd>	Sets the real time clock date.
:ERRor?	Reads and clears one error from the error queue.
:KLOCK	Nonvolatile keyboard lock.
:LICense	
:DESCription? "<option name>"	Returns a description of an option.
:INSTall "<license_string>"	Installs a licensed option.
:INSTall? "<option name>"	Indicates whether an option is installed.
:REBoot	Reboots the unit to its power-on state.
:SECurity	
:IMMEDIATE	Sanitizes all user data and reboots the instrument.
:TIME <hh,mm,ss>	Sets the real-time clock time.
:VERSion?	Returns the SCPI version that the instrument complies with.

**TRIGger**

[:TRANsient]	
[:IMMEDIATE]	Generates an immediate trigger.
:SOURce BUS IMMEDIATE EXTERNAL	Selects the measurement trigger source.

## Abort Command

Abort cancels any pending triggers. Trigger commands control the remote triggering of the instrument's output. Initiate commands initiate the transient trigger system.

### **ABORt[:TRANsient]**

Cancels any triggered actions.

Parameter	Typical Return
(none)	(none)
Cancels the triggered action: <b>ABOR</b>	

## Analog Commands

### **[SOURce:]ANALog:RANGe 5|10**

### **[SOURce:]ANALog:RANGe?**

Sets the full-scale analog programming and monitor range.

Programming – 5/10 Volts or 5/10 k $\Omega$ .

Monitoring – 5/10 Volts.

Parameter	Typical Return
5 10, *RST 5	5 or 10

## Common Commands (IEEE-488)

Common commands generally control overall instrument functions, such as reset, status, and synchronization. All common commands consist of a three-letter mnemonic preceded by an asterisk: \*RST \*IDN? \*SRE 8.

### \*CLS

*Clear Status Command.* Clears the Event registers in all register groups. Also clears the Status Byte and Error Queue. If \*CLS immediately follows a program message terminator (<NL>), then the Output Queue and the MAV bit are also cleared. Refer to the [Status diagram](#) for details.

Parameter	Typical Return
(none)	(none)
Clear Event register bits, Status byte, and Error queue: *CLS	

### \*ESE <value>

### \*ESE?

*Event Status Enable Command and Query.* Enables bits in the Enable register for the Standard Event Status group. A 1 in the bit position enables the corresponding event. The selected bits are then reported to the ESB bit of the Status Byte Register. The query reads the enable register and returns a decimal value which corresponds to the binary-weighted sum of all bits set in the register. Refer to the [Status diagram](#) for details.

The following table describes the Standard Event Status register bit assignments.

Bit	Bit Name	Decimal Value	Definition
0	Operation Complete	1	All commands before and including *OPC have been executed.
1	not used	not used	0 is returned
2	Query Error	4	The instrument tried to read the output buffer but it was empty, a new command line was received before a previous query has been read, or both the input and output buffers are full.
3	Device-Specific Error	8	A device-specific error, including a self-test error, calibration error or other device-specific error occurred. <a href="#">Error Messages</a>
4	Execution Error	16	An execution error occurred. <a href="#">Error Messages</a>
5	Command	32	A command syntax error occurred. <a href="#">Error Messages</a>
6	not used	not used	0 is returned
7	Power On	128	Power has been cycled since the last time the event register was read or cleared.

Parameter	Typical Return
A decimal value that corresponds to the binary-weighted sum of the bits in the register.	<bit value>
Enable bit 3 and 4 in the enable register: *ESE 24	

- Any or all conditions can be reported to the ESB bit through the enable register. To set the enable register mask, write a decimal value to the register using \*ESE.
- \*CLS does not clear the enable register, but does clear the Event register.
- The value returned is the binary-weighted sum of all bits set in the register.

### \*ESR?

*Event Status Event Query.* Queries the Event register for the Standard Event Status group. The event register is a read-only register, which stores (latches) all standard events. Refer to the [Status diagram](#) for details.

Parameter	Typical Return
(none)	<bit value>
Read event status enable register: *ESR?	

- Any or all conditions can be reported to the ESB bit through the enable register. To set the enable register mask, write a decimal value to the register using \*ESE.
- Once a bit is set, it remains set until cleared by this query or \*CLS.
- The value returned is the binary-weighted sum of all bits set in the register.

### \*IDN?

*Identification Query.* Returns instrument's identification string, which contains four comma-separated fields. The first field is the manufacturer's name, the second field is the instrument model number, the third field is the serial number, and the fourth field is the firmware revision.

Parameter	Typical Return
(none)	Agilent Technologies,N8925A,MY00123456,A.01.01
Return the instrument's identification string: *IDN?	

**\*OPC**

Sets the OPC (operation complete) bit in the Standard Event register. This occurs at the completion of the current operation.

Parameter	Typical Return
(none)	(none)
Set the Operation Complete bit: <code>*OPC</code>	

- The purpose of this command is to synchronize your application with the instrument.
- Used in conjunction with initiated acquisitions, initiated transients, output state changes, and output to settling time to provide a way to poll or interrupt the computer when these pending operations complete.
- Other commands may be executed before the operation complete bit is set.
- The difference between `*OPC` and `*OPC?` is that `*OPC?` returns "1" to the output buffer when the current operation completes.

**\*OPC?**

Returns a 1 to the output buffer when all pending operations complete. The response is delayed until all pending operations complete. Other commands cannot be executed until this command completes.

Parameter	Typical Return
(none)	1
Return a 1 when commands complete: <code>*OPC?</code>	

- The purpose of this command is to synchronize your application with the instrument.

**\*OPT?**

Returns a string identifying any installed options. A 0 (zero) indicates no options are installed.

Parameter	Typical Return
(none)	OPT 760
Returns installed options: <code>*OPT?</code>	

Also see: [SCPI Commands Related to Option DP5705A](#)

**\*RCL <0-9>****WARNING**

**SHOCK HAZARD** If the output is enabled when an instrument state is saved to location 0 (zero), the output will automatically be enabled at turn-on if the power-on state is set to recall location zero (RCL0).

---

Restores the instrument to a state that was previously stored in memory locations 0 through 9 with the \*SAV command. All instrument states are recalled except: (1) the trigger system is set to the Idle state, (2) calibration is disabled, (3) trigger settings are set to their Idle state, and (4) non-volatile settings are not affected.

Parameter	Typical Return
0 - 9	(none)
Recall state from location 1: *RCL 1	

- Location 0 is automatically recalled at power turn-on when the Output Power-On state is set to RCL0.
- You cannot recall an instrument state from an empty or deleted storage location.
- Stored instrument states are affected by \*RST.

**\*RST**

Resets the instrument to pre-defined values that are either typical or safe. These settings are described in **Factory Reset State**.

Parameter	Typical Return
(none)	(none)
Reset the instrument: *RST	

- \*RST forces the ABORT command. This cancels any trigger actions presently in process, and resets the WTG bit in the Status Operation Condition register.

**\*SAV <0-9>**

Saves the present state of the instrument to one of ten non-volatile memory locations.

Parameter	Typical Return
0 - 9	(none)
Save state to location 1: *SAV 1	

- If a particular state is desired at power-on, it should be stored in location 0. Location 0 is automatically recalled at power turn-on when the Output Power-On state is set to RCL 0.
- The calibration state is NOT saved as part of the \*SAV operation.
- Data saved in non-volatile memory, described in the Non-volatile Settings, is not affected by the \*SAV command.
- When shipped, locations 0 through 9 are empty.

**\*SRE <value>****\*SRE?**

*Service Request Enable Command and Query.* Sets the value of the Service Request Enable register. This determines which bits from the Status Byte Register are summed to set the Master Status Summary (MSS) bit and the Request for Service (RQS) summary bit. A 1 in any Service Request Enable register bit position enables the corresponding Status Byte register bit. All such enabled bits are then logically OR-ed to cause the MSS bit of the Status Byte register to be set. Refer to the [Status diagram](#) for details.

The query reads the current state of the Service Request Enable register and returns a decimal value which corresponds to the binary-weighted sum of all bits set in the register.

Parameter	Typical Return
A decimal value that corresponds to the binary-weighted sum of the bits in the register.	<bit value>
Enable bit 3 and 4 in the enable register: *SRE 24	

- When a serial poll is conducted in response to SRQ, the RQS bit is cleared, but the MSS bit is not.
- When \*SRE is cleared (by programming it with 0), the power supply cannot generate an SRQ to the controller.

**\*STB?**

*Status Byte Query.* Reads the Status Byte Register, which contains the status summary bits and the Output Queue MAV bit. The Status Byte is a read-only register and the input bits are not cleared when it is read. The input bits are cleared when the appropriate event registers are read. The MAV bit is cleared at power-on, by \*CLS' or when there is no more response data available. Refer to the **Status diagram** for details.

The following table describes the Status Byte register bit assignments.

Bit	Bit Name	Decimal Value	Definition
0	not used	not used	0 is returned
1	not used	not used	0 is returned
2	Error Queue	4	One or more errors in the Error Queue. Use SYSTem:ERRor? to read and delete errors.
3	Questionable Status Summary	8	One or more bits are set in the Questionable Data Register. Bits must be enabled, see STATus:QUEStionable:ENABle.
4	Message Available	16	Event or error messages are available in the instrument's Output Queue. Messages are stored until they are read with SYSTem:ERRor?
5	Event Status Summary	32	One or more bits are set in the Standard Event Register. Bits must be enabled, see *ESE.
6	Master Status Summary (MSS)/ Service Request (RQS)	64	One or more bits are set in the Status Byte Register and may generate a Service Request. Bits must be enabled, see *SRE.  The RQS bit is a latched version of the MSS bit. Whenever the instrument requests service, it sets the SRQ interrupt line true and latches RQS into bit 6.
7	Operation Status Summary	128	One or more bits are set in the Operation Status Register. Bits must be enabled, see STATus:OPERation:ENABle.

Parameter	Typical Return
(none)	<bit value>
Read status byte: *STB?	

- When a serial poll is conducted in response to SRQ, the RQS bit is cleared, but the MSS bit is not.
- A serial poll also returns the value of the Status Byte register, except that bit 6 returns Request for Service (RQS) instead of Master Status Summary (MSS).

**\*TST?**

*Self-Test Query.* Performs an instrument self-test. If test fails, one or more error messages will provide additional information. Use SYSTem:ERRor? to read error queue. See [SCPI Error Messages](#) for more information.

Parameter	Typical Return
(none)	0 if no errors, 1 if errors occurred
Perform self-test: *TST?	

**\*WAI**

Pauses additional command processing until all pending operations are complete. See [OPC](#) for more information.

Parameter	Typical Return
(none)	(none)
Wait until all pending operations complete. *WAI	

- \*WAI can only be aborted by sending the instrument a command.

## Current Commands

Current commands program the output current and current protection functions. The **SOURce** keyword is optional in the following commands.

**[SOURce:]CURRENT:ANALog:LIMit:STATe 0|OFF|1|ON**

**[SOURce:]CURRENT:ANALog:LIMit:STATe?**

Enables/disables the digital current limit while in analog control mode. If enabled, the current programmed via the rear panel analog control signal is limited to no more than the digital (SCPI or front panel) current programming value.

Parameter	Typical Return
0 OFF 1 ON, *RST OFF	0 or 1

**[SOURce:]CURRENT:ANALog:SOURce OFF|VOLTage|RESistance**

**[SOURce:]CURRENT:ANALog:SOURce?**

Turns on or off analog programming of current, and selects the type of analog programming.

**OFF** – Current is controlled by SCPI or the front panel setting. Analog control is off.

**VOLTage** – Current is controlled by an analog voltage signal.

**RESistance** – Current is controlled by an analog resistance.

Parameter	Typical Return
OFF VOLTage RESistance, *RST OFF	0 or 1

**[SOURce:]CURRENT:MODE FIXed|STEP|LIST**

**[SOURce:]CURRENT:MODE?**

Sets the transient mode. This determines what happens to the output current when the transient system is initiated and triggered.

**FIXed** keeps the output current at its immediate value.

**STEP** steps the output to the triggered level when a trigger occurs.

**LIST** causes the output to follow the list values when a trigger occurs.

Parameter	Typical Return
FIXed STEP LIST, *RST FIXed	FIX, STEP, or LIST

**[SOURce:]CURRENT[:LEVel][:IMMediate][:AMPLitude] <curr>|MIN|MAX**

**[SOURce:]CURRENT[:LEVel][:IMMediate][:AMPLitude]? [MIN|MAX]**

**[SOURce:]CURRENT[:LEVel]:TRIGgered[:AMPLitude] <value>|MIN|MAX**

**[SOURce:]CURRENT[:LEVel]:TRIGgered[:AMPLitude]? [MIN|MAX]**

Sets the immediate or triggered current level. The triggered level is a stored value that is transferred to the output when an output Step is triggered. Units are in amperes. The maximum value depends on the current rating of the unit.

Parameter	Typical Return
0 to 105% of rating MIN MAX, *RST 0	<current level>
Sets the output current level to 3 A: CURR 3	

**[SOURce:]CURRENT:PROTection:DELAy<delay>|MIN|MAX**

**[SOURce:]CURRENT:PROTection:DELAy? [MIN|MAX]**

Sets the over-current protection delay. The over-current protection function will not be triggered during the delay time. After the delay time has expired, the over-current protection function will be active. This prevents momentary changes in output status from triggering the over-current protection function.

Parameter	Typical Return
0.1 to 25.5 s, *RST 0.1 s	<delay value>
Sets the protection delay to 0.2 seconds: CURR:PROT:DEL 0.2	

**[SOURce:]CURRENT:PROTection:STATe 0|OFF|1|ON**

**[SOURce:]CURRENT:PROTection:STATe?**

Enables or disables the over-current protection. If the over-current protection function is enabled and the output goes into constant current operation, the output is disabled and the Questionable Condition status register OCP bit is set.

Parameter	Typical Return
0 OFF 1 ON, *RST OFF	0 or 1
Enable the current protection state: CURR:PROT:STAT ON	

- The current limit setting determines when the output goes into constant current operation.
- An over-current condition can be cleared with OUTPut:PROTection:CLEar after the cause of the condition is removed.

**[SOURce:]CURRent:SLEW:POSitive[:IMMEDIATE] <slew>****[SOURce:]CURRent:SLEW:NEGative[:IMMEDIATE] <slew>**

Sets the current slew rate. The slew rate is set in amps per second. The slew rate can be set to any value between 0.1 and 9.9999E+5. For very large values, the slew rate will be limited by the unit's listed programming speed and bandwidth. Keyword MAX sets the slew rate to maximum.

Parameter	Typical Return
0.1 to 9.9999E+5 MIN MAX, *RST MAX	<max value>
Sets the current slew rate to 0.5 A per second: <code>CURR:SLEW 0.5</code>	

- The front panel displays the slew rate in amps per millisecond, rather than amps per second. Therefore the range of settings on the front panel is 0.0001 to 999.99.

## Digital Commands

The SOURce keyword is optional in the following commands.

**[SOURce:]DIGital:OUTPut:DATA <data>****[SOURce:]DIGital:OUTPut:DATA?**

Controls the digital output pins on rear panel connector J1.

Bit 0 of <data> controls J1 pin 21. Bit 1 of <data> controls J1 pin 20.

Each output is open-drain, i.e. it is pulled down by a MOSFET. For each output, a bit value of 0 turns on the MOSFET, pulling the output low. A bit value of 1 turns off the MOSFET.

Parameter	Typical Return
0 to 3 (2 bits of digital data)	0 to 3

**[SOURce:]DIGital:PIN10:POLarity POSitive|NEGative****[SOURce:]DIGital:PIN10:POLarity?**

This sets the polarity of the rear panel ENA signal.

**NEGative** - inhibits the output if the ENA signal is Low.

**POSitive** - inhibits the output if the ENA signal is High.

This setting is stored in non-volatile memory.

Parameter	Typical Return
NEGative POSitive	NEG or POS

The ENA signal is enabled or disabled via **OUTPut:INHibit:MODE**.

### **[SOURce]:DIGital:PTRG:FUNCTion OFF|FSTR|TRIG**

#### **[SOURce]:DIGital:PTRG:FUNCTion?**

Sets the operation of the Trigger Out signal (J1 pin 23).

Programming Mode - FIXed:

- In TRIG mode, a trigger pulse is generated when the output state changes.
- In FSTR mode, a trigger pulse is generated any time an output parameter, such as output state, voltage, or current is programmed.

Programming Mode - LIST:

- In TRIG mode, a trigger pulse is generated when the list has completed.
- In FSTR mode, a trigger pulse is generated each time a list step has completed.

Parameter	Typical Return
OFF FSTR TRIG, *RST OFF	OFF, FSTR, or TRIG

## Display Command

### **DISPlay[:WINDow][:STATe] 0|OFF|1|ON**

#### **DISPlay[:WINDow][:STATe]?**

Turns the front panel display and the front panel buttons on or off. It does not affect the power switch.

Parameter	Typical Return
0 OFF 1 ON, *RST ON	0 or 1
Turns the front panel display off: <b>DISP OFF</b>	

## Initiate Commands

Initiate commands initiate the trigger system. Trigger commands control the remote triggering of the instrument's output list. Abort commands abort any pending triggers.

### **INITiate[:IMMediate][:TRANsient]**

Initiates the trigger system. This moves the trigger system from the "idle" state to the "wait-for-trigger" state, which enables the instrument to receive triggers.

Parameter	Typical Return
(none)	(none)
Initiates the trigger system: <code>INIT:TRAN</code>	

- It takes a few milliseconds for the instrument to be ready to receive a trigger signal after receiving the INITiate command.
- If a trigger occurs before the trigger system is ready for it, the trigger will be ignored. Check the WTG\_tran bit in the operation status register to know when the instrument is ready.
- Use ABORt to return the instrument to idle.

### **INITiate:CONTInuous[:TRANsient] 0|OFF|1|ON**

#### **INITiate:CONTInuous[:TRANsient]?**

Continuously initiates the transient trigger system. This allows multiple triggers to generate multiple output transients.

Parameter	Typical Return
0 OFF 1 ON, *RST ON	0 or 1
Continually initiates the trigger system: <code>INIT:CONT ON</code>	

- With continuous triggering disabled, the trigger system must be initiated for each trigger using the INITiate command.
- ABORt does not abort continuous triggers if INITiate:CONTInuous ON has been programmed. In this case, the trigger system will automatically re-initiate.

## Instrument Commands

### INSTRument:GROup:ACKnowledge

Acknowledges a change in parallel assembly when the unit functions as a primary unit.

Parameter	Typical Return
(none)	(none)

### INSTRument:GROup:COUNT?

Returns the total number of units in the configuration.

Parameter	Typical Return
(none)	1 to 12

### INSTRument:GROup:FUNCTion?

Queries the function of an instrument in a primary/secondary configuration.

Parameter	Typical Return
(none)	<b>PRIMary</b> - The instrument is the primary unit in a primary/secondary group.
(none)	<b>SECOndary</b> - The instrument is a secondary unit in a primary/secondary group.
(none)	<b>NONE</b> - The unit is operating independently.

## List Commands

To create a valid list, all programmed lists (Voltage, Current, BOST, EOST, or Dwell) must either all be the same length, or have a length of 1, which is interpreted as having the same length as the list with the maximum length.

The order in which the voltage values are entered determines the sequence when the list executes.

Whenever a list is programmed, it overwrites any previously programmed list; it does not append to the previous list

**[SOURce:]LIST:COUNT <repeatcount>**

**[SOURce:]LIST:COUNT?[MIN|MAX]**

Sets the number of times that the list is executed before it is completed. The repeat count range is 1 through 9999, or INFinity.

The query returns the repeat count. If a repeat count of 9.9E37 is returned, it means the list is set to repeat continuously.

Parameter	Typical Return
1 to 9999, or INFinity, *RST 1	<list count>
Sets the list count to 10: LIST:COUNT 10	

**[SOURce:]LIST:CURREnt[:LEVel] <curr> {,<curr ...>}**

**[SOURce:]LIST:CURREnt[:LEVel]?**

**[SOURce:]LIST:VOLTage[:LEVel] <volt> {,<volt ...>}**

**[SOURce:]LIST:VOLTage[:LEVel]?**

Specifies the current or voltage setting for each corresponding list step in amperes or volts. A comma-delimited list of up to 100 steps may be programmed.

The queries return the programmed current or voltage level in the form +n.nnnnnnE+nn. Multiple responses are separated by commas.

Parameter	Typical Return
0 to 105% of current or voltage rating	<value 1>,<value 2>,<value 3>...
Programs a current list of 3 steps: LIST:CURREnt 3, 2, 1	
Programs a voltage list of 5 steps: LIST:VOLTage 30, 35, 40, 45, 50	

**[SOURce:]LIST:CURRent:POINts?****[SOURce:]LIST:DWELL:POINts?****[SOURce:]LIST:VOLTage:POINts?**

Returns the number of points in the specified list. Points are the same as steps. The queries do not return the point values.

Parameter	Typical Return
None	<points>
Returns the number of points in the current list: <code>LIST:CURR:POIN?</code>	

**[SOURce:]LIST:DWELL <time> {,<time ...>}****[SOURce:]LIST:DWELL?**

Specifies the dwell time for each list step. A comma-delimited list of up to 100 steps may be programmed. Dwell time is the time that the output will remain at a specific step. Dwell times can be programmed from 0.001 to 129600 seconds.

The query returns the programmed dwell times in the form +n.nnnnnnE+nn. Multiple responses are separated by commas.

Parameter	Typical Return
0.001 to 129600 s, *RST 0.001	<value 1>,<value 2>,<value 3>...
Programs a dwell list. The list contains 3 steps: <code>LIST:DWEL 0.4,0.8,1.6</code>	

**[SOURce:]LIST:STEP ONCE|AUTO,****[SOURce:]LIST:STEP?**

Specifies how the list responds to triggers:

**ONCE** - causes the output to remain at the present step until a trigger advances it to the next step. Triggers that arrive during the dwell time are ignored.

**AUTO** - causes the output to automatically advance to each step, after the receipt of an initial starting trigger. Steps are paced by the dwell list. After each dwell elapses, the next step is immediately output.

The query returns the list step setting.

Parameter	Typical Return
ONCE AUTO, *RST AUTO	ONCE AUTO
Specifies the list steps to be paced by trigger signals: <code>LIST:STEP ONCE</code>	

## LXI Commands

Also see [System Commands](#).

### LXI:IDENTify:STATe 0|OFF|1|ON

#### LXI:IDENTify:STATe?

Starts or stops flashing of the LAN annunciator on the front panel display, to help identify the device associated with a LAN address.

Parameter	Typical Return
0 OFF 1 ON	0 or 1

#### LXI:MDNS:HNAME?

Returns the instrument's Multicast Domain Name System (mDNS) host name.

Parameter	Typical Return
(none)	"K-DP5736A-83401"

#### LXI:MDNS:SNAME?

Returns the instrument's Multicast Domain Name System (mDNS) service name.

Parameter	Typical Return
(none)	"Keysight DP5736A System Power Supply - 23L183401"

### LXI:MDNS[:STATe] 0|OFF|1|ON

#### LXI:MDNS[:STATe]?

Enables or disables the Multicast Domain Name System (mDNS).

Parameter	Typical Return
0 OFF 1 ON	0 or 1

#### LXI:RESet

Resets LAN settings to a known operating state, including enabling DHCP. Restarts the LAN interface.

Parameter	Typical Return
(none)	(none)

## Measure Commands

Measure commands measure the output voltage, current, or power. They trigger the acquisition of new data before returning the reading. Measurement overflows return a reading of 9.91E+37.

**MEASure[:SCALar]:CURRent[:DC]?**

**MEASure[:SCALar]:POWer[:DC]?**

**MEASure[:SCALar]:VOLTage[:DC]?**

These commands initiate and trigger a measurement. They return the averaged output measurement. Values returned are either in amperes, volts, or watts.

Parameter	Typical Return
(none)	<DC value>
Returns the averaged current	MEAS:CURR?
Returns the averaged power	MEAS:POW?
Returns the averaged voltage	MEAS:VOLT?

## Output Commands

Output commands control the output, power-on, and protection clear functions.

### OUTPut[:STATe] 0|OFF|1|ON

#### OUTPut[:STATe]?

**WARNING**

Many models generate voltages above 60 VDC, with some models rated at up to 1,500 VDC! Ensure that all instrument connections, load wiring, and load connections are insulated or covered so that no accidental contact with lethal voltages can occur.

Enables or disables the output. The state of a disabled output is a condition of zero output voltage and zero current.

Parameter	Typical Return
0 OFF 1 ON, *RST OFF	0 or 1
Turns the output off: <code>OUTP OFF</code>	

- With the output enabled, the instrument status changes from **OFF** to the operating status (ex: CV).

### OUTPut:INHibit:MODE LATChing|OFF

#### OUTPut:INHibit:MODE?

This enables (LATChing) or disables (OFF) the ENA (enable) function on the rear panel of the instrument (J1 pin 10). This function serves as an output control when connected to an external switch or voltage. When disabled, the instrument ignores the ENA signal. This setting is stored in non-volatile memory.

Parameter	Typical Return
LATChing OFF	LATC or OFF

The ENA polarity is set via **DIGital:PIN10:POLarity**.

**OUTPut:INTerlock[:STATe] 0|OFF|1|ON****OUTPut:INTerlock:STATe?**

This enables or disables the ILC (interlock) function on the rear panel of the instrument (J1 pin 19). This function serves as an emergency shutoff when connected to an emergency shutoff switch or open-door switch. When disabled, the instrument ignores the ILC signal. The ILC input disables the output if the ILC signal pin is shorted or 0~0.6 V. This setting is stored in non-volatile memory.

Parameter	Typical Return
0 OFF 1 ON	0 or 1

**OUTPut:PON:STATe RST|RCL0****OUTPut:PON:STATe?**

Sets the output power-on state. This determines whether the power-on state is set to the \*RST state (RST) or the state stored in memory location 0 (RCL0). Instrument states can be stored using the \*SAV command. This setting is saved in non-volatile memory.

Parameter	Typical Return
RST RCL0	RST or RCL0

**OUTPut:PRELoad[:STATe] 0|OFF|1|ON****OUTPut:PRELoad[:STATe]?**

Preload determines the power supply's behavior when the output is in the off state.

With preload off, when the output is turned off the unit attempts to draw down-programming current (to discharge the output capacitance) for 7 seconds, and then the current goes to zero.

With preload on, while the output is off the unit attempts to draw down-programming current continuously.

In both cases, down-programming current flows only while there is sufficient voltage on the output to support it.

This command does not affect down-programming behavior when the output is on and the voltage set-point is lowered. In that case the unit draws down-programming current continuously as long as the output voltage remains above the set-point.

The magnitude of the down-programming current is not adjustable by the user.

Parameter	Typical Return
0 OFF 1 ON, *RST OFF	0 or 1

**OUTPut:PROTection:CLEar**

This clears the latched protection status that disables the output when a protection condition occurs (see **Programming Output Protection**). The output is restored to the state it was in before the protection condition occurred.

Parameter	Typical Return
(none)	(none)
Clears the latched protection status: <code>OUTP:PROT:CLE</code>	

- All conditions that generate the fault must be removed before the latched status can be cleared.

## Power Commands

The SOURce keyword is optional in the following commands.

Sets the power level when constant power operation is enabled. Units are in watts. The maximum value depends on the power rating of the unit.

**[SOURce:]POWER[:LEVel][:IMMEDIATE][:AMPLitude] <value>|MIN|MAX**

**[SOURce:]POWER[:LEVel][:IMMEDIATE][:AMPLitude]? [MIN|MAX]**

Sets the power level when constant power operation is enabled. Units are in watts. The maximum value depends on the power rating of the unit.

Parameter	Typical Return
1 W to 100% of rating, *RST 0	<power level>

**[SOURce:]POWER:STATE 0|OFF|1|ON**

**[SOURce:]POWER:STATE?**

Enables or disables constant power operation.

Parameter	Typical Return
0 OFF 1 ON, *RST OFF	0 or 1

## Slew Commands

The SOURce keyword is optional in the following commands.

**[SOURce:]SLEW:FUNCTION NONE|VOLTage|CURRent**

**[SOURce:]SLEW:FUNCTION?**

Only one parameter at a time, either voltage or current, can be slewed. This command makes the selection.

Refer to the **[SOURce:]CURRENT:SLEW** and **[SOURce:]VOLTage:SLEW** commands.

Parameter	Typical Return
NONE VOLTage CURRent, *RST NONE	NONE, VOLT, or CURR

## Status Commands

Status commands let you determine the operating condition of the instrument at any time. As shown in the following figure, the instrument has three groups of status registers: Operation, Questionable, and Standard Event.

The Operation and Questionable status groups each consist of Condition, Event, and Enable registers as well as NTR and PTR filters that let you track, qualify, flag, and enable instrument events.

- A Condition register continuously monitors the state of the instrument. The bits in the condition register are updated in real time and the bits are not latched or buffered
- An PTR/NTR register qualifies the signal that passes to the event register. When a PTR bit is set, signals with positive edge transition pass to the event register. When an NTR bit is set, signals with a negative edge transition pass to the event register. When both bits are set, all signal pass. When neither bits are set, no signals pass.
- An Event register latches the various events from the condition register. There is no buffering in this register; while an event bit is set, subsequent events corresponding to that bit are ignored. This is a read-only register.
- An Enable register defines which bits in the event register will be reported to the Status Byte register group. You can write to or read from an enable register.

To program individual bits in any register group, you must send a value that corresponds to the binary-weighted value of all the bits that you wish to enable. For example, to enable bit 2 (decimal value = 4) and bit 4 (decimal value = 16), the corresponding decimal value would be 20 (4 + 16). Similarly, any register queries return the binary-weighted value of the bits that have been set. For example, with bit 3 (value 8) and bit 5 (value 32) being set, the query returns +40.

Instrument status is also programmed using the Common commands: **\*CLS**, **\*ESE**, **\*ESR?**, **\*OPC**, **\*OPC?**, **\*SRE**, **\*STB?** and **\*WAI**. Common commands control additional status functions such as the Service Request Enable and the Status Byte registers.

The following is a diagram of the status registers

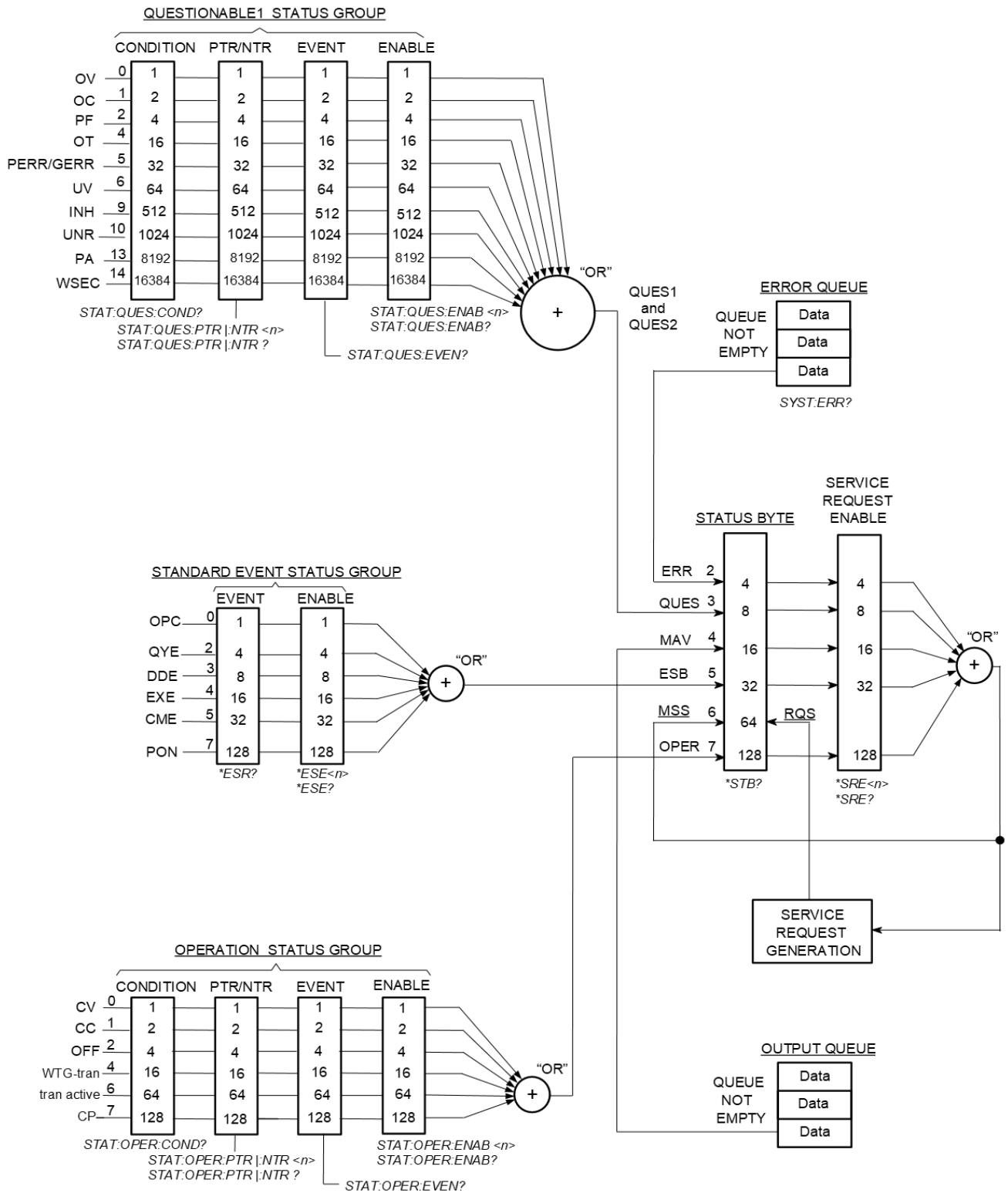

**STATus:OPERation[:EVENT]?**

Queries the **Event register** for the Operation status group. This is a read-only register, which stores (latches) all events that are passed by the Operation NTR and PTR filter. Reading the Operation Status Event register clears it. The bit configuration of the Operation Status registers is as follows.

Bit	Bit Name	Decimal Value	Definition
0	CV	1	Output is in constant voltage
1	CC	2	Output is in constant current
2	OFF	4	Output is programmed off
4	WTG-tran	16	Transient system is waiting or a trigger
6	tran active	64	Transient system is active
7	CP	128	Output is in constant power mode

Parameter	Typical Return
(none)	<bit value>
Read the operation status event register: STAT:OPER?	

- \*RST has no effect on this register.
- The value returned is the binary-weighted sum of all bits set in the register.

**STATus:OPERation:CONDition?**

Queries the **Condition register** for the Operation status group. This is a read-only register, which holds the live (unlatched) operational status of the instrument. Reading the Operation Status Condition register does not clear it.

Parameter	Typical Return
(none)	<bit value>
Read the operation status condition register: STAT:OPER:COND?	

- The condition register bits reflect the current condition. If a condition goes away, the corresponding bit is cleared.
- The value returned is the binary-weighted sum of all bits set in the register.

**STATus:OPERation:ENABLE <value>****STATus:OPERation:ENABLE?**

Sets and queries bits in the **Enable register** for the Operation status group. The enable register is a mask for enabling specific bits from the Operation Event register to set the OPER (operation summary)

bit of the Status Byte register. STATus:PRESet clears all bits in the enable register.

Parameter	Typical Return
A decimal value that corresponds to the binary-weighted sum of the bits in the register.	<bit value>
Enable bit 3 and 4 in the enable register: STAT:OPER:ENAB 24	

- \*CLS does not clear the enable register, but does clear the event register.

### STATus:OPERation:NTRansition <value>

#### STATus:OPERation:NTRansition?

### STATus:OPERation:PTRansition <value>

#### STATus:OPERation:PTRansition?

Sets and queries the value of the **NTR** (Negative-Transition) and **PTR** (Positive-Transition) registers. These registers serve as a polarity filter between the Operation Condition and Operation Event registers.

When a bit in the NTR register is set to 1, then a 1-to-0 transition of the corresponding bit in the Operation Condition register causes that bit in the Operation Event register to be set.

When a bit in the PTR register is set to 1, then a 0-to-1 transition of the corresponding bit in the Operation Condition register causes that bit in the Operation Event register to be set.

STATus:PRESet sets all bits in the PTR registers and clears all bits in the NTR registers.

Parameter	Typical Return
A decimal value that corresponds to the binary-weighted sum of the bits in the register.	<bit value>
Enable bit 3 and 4 in the NTR register: STAT:OPER:NTR 24 Enable bit 3 and 4 in the PTR register: STAT:OPER:PTR 24	

- If the same bits in both NTR and PTR registers are set to 1, then any transition of that bit at the Operation Condition register sets the corresponding bit in the Operation Event register.
- If the same bits in both NTR and PTR registers are set to 0, then no transition of that bit at the Operation Condition register can set the corresponding bit in the Operation Event register .
- The value returned is the binary-weighted sum of all bits set in the register.

**STATus:PRESet**

Presets all Enable, PTR, and NTR registers.

Operation register	Questionable register	Preset setting
STAT:OPER:ENAB	STAT:QUES:ENAB	all defined bits are disabled
STAT:OPER:NTR	STAT:QUES:NTR	all defined bits are disabled
STAT:OPER:PTR	STAT:QUES:PTR	all defined bits are enabled

Parameter	Typical Return
(none)	(none)

Preset the Operation and Questionable registers: STAT:PRES

**STATus:QUESTIONable[:EVENT]?**

Queries the **Event register** for the Questionable status group. This is a read-only register, which stores (latches) all events that are passed by the Operation NTR and PTR filter. Reading the Questionable Status Event register clears it.

Bit	Bit Name	Decimal Value	Definition
0	OV	1	Output is disabled by the over-voltage protection
1	OC	2	Output is disabled by the over-current protection
2	PF	4	Output is disabled by power-fail (low-line or brownout on AC line)
4	OT	16	Output is disabled by the over-temperature protection
5	PERR/GERR	32	Parallel Error/ General Error
6	UV	64	Output is disabled by the under-voltage protection
9	INH	512	Output is disabled by an external INHibit signal
10	UNR	1024	Output is unregulated
13	PA	8192	Parallel configuration has changed and needs to be acknowledged
14	WSEC	16384	Waiting for secondary to become available

Parameter	Typical Return
(none)	<bit value>

Read questionable status event register: STAT:QUES?

- \*RST has no effect on this register.
- The value returned is the binary-weighted sum of all bits set in the register.

**STATus:QUESTionable:CONDition?**

Queries the **Condition register** for the Questionable status group. This is a read-only register, which holds the live (unlatched) operational status of the instrument. Reading the Questionable Status Condition register does not clear it.

Parameter	Typical Return
(none)	<bit value>
Read questionable status condition register: STAT:QUES:COND?	

- The condition register bits reflect the current condition. If a condition goes away, the corresponding bit is cleared.
- \*RST clears this register, other than those bits where the condition still exists after \*RST.
- The value returned is the binary-weighted sum of all bits set in the register.

**STATus:QUESTionable:ENABLE <value>****STATus:QUESTionable:ENABLE?**

Sets and queries bits in the **Enable register** for the Questionable status group. The enable register is a mask for enabling specific bits from the Operation Event register to set the QUES (questionable summary) bit of the Status Byte register. STATus:PRESet clears all bits in the enable register.

Parameter	Typical Return
A decimal value that corresponds to the binary-weighted sum of the bits in the register.	<bit value>
Enable bit 2 and 4 in the questionable enable register: STAT:QUES:ENAB 24	

- \*CLS does not clear the enable register, but does clear the event register.

**STATus:QUESTionable:NTRansition <value>****STATus:QUESTionable:NTRansition?****STATus:QUESTionable:PTRansition <value>****STATus:QUESTionable:PTRansition?**

Sets and queries the value of the **NTR** (Negative-Transition) and **PTR** (Positive-Transition) registers. These registers serve as a polarity filter between the Questionable Condition and Questionable Event registers.

When a bit in the NTR register is set to 1, then a 1-to-0 transition of the corresponding bit in the Questionable Condition register causes that bit in the Questionable Event register to be set.

## 5 SCPI Programming Reference

When a bit in the PTR register is set to 1, then a 0-to-1 transition of the corresponding bit in the Questionable Condition register causes that bit in the Questionable Event register to be set.

STATus:PRESet sets all bits in the PTR registers and clears all bits in the NTR registers.

Parameter	Typical Return
A decimal value that corresponds to the binary-weighted sum of the bits in the register.	<bit value>
Enable bit 3 and 4 in the questionable NTR register: STAT:QUES:NTR 24	
Enable bit 3 and 4 in the questionable PTR register: STAT:QUES:PTR 24	

- If the same bits in both NTR and PTR registers are set to 1, then any transition of that bit at the Questionable Condition register sets the corresponding bit in the Questionable Event register.
- If the same bits in both NTR and PTR registers are set to 0, then no transition of that bit at the Questionable Condition register can set the corresponding bit in the Questionable Event register .
- The value returned is the binary-weighted sum of all bits set in the register.

## System Commands

System commands control system functions that are not directly related to output control, measurement, or status functions. Also see [LXI Commands](#).

System functions are also controlled using the Common commands: \*IDN?, \*LRN?, \*OPT?, \*RCL, \*RST, \*SAV, and \*TST?

### **SYSTem:COMMunicate:LAN:CONTrol?**

### **SYSTem:COMMunicate:TCPIP:CONTrol?**

Returns the initial socket control connection port number. This connection is used to send and receive commands and queries. Unlike the data socket, which uses a fixed port number, the control socket port number varies and must be obtained using these queries.

Parameter	Typical Return
(none)	5000 (0 if sockets are not supported)

Query the Control connection port number:  
 SYST:COMM:LAN:CONT? or SYST:COMM:TCP:CONT?

### **SYSTem:COMMunicate:LAN:DHCP 0|OFF|1|ON**

### **SYSTem:COMMunicate:LAN:DHCP?**

Enables or disables the Dynamic Host Configuration Protocol (DHCP). When enabled, the device's LAN parameters will be obtained automatically from a DHCP server, if one exists on the network.

A power cycle may be required for this setting to take effect. This setting is stored in non-volatile memory.

Parameter	Typical Return
0 OFF 1 ON	0 or 1

**SYSTem:COMMunicate:LAN:DNS "<address>"****SYSTem:COMMunicate:LAN:DNS? [CURRent | STATic]**

Assigns a Domain Name System (DNS) server to be used when DHCP is disabled. Note that the quotes around the address are required.

The CURRent query returns the data that is presently in use, whether assigned by DHCP or statically. The STATic query returns the data that was assigned via the command. If the optional parameter is omitted from the query, the default is CURRent.

A power cycle may be required for this setting to take effect. This setting is stored in non-volatile memory.

Parameter	Typical Return
"xxx.xxx.xxx.xxx"	"15.114.7.11"

**SYSTem:COMMunicate:LAN:DOMain "<name>"****SYSTem:COMMunicate:LAN:DOMain? [CURRent | STATic]**

Assigns a domain name to be used when DHCP is disabled. Note that the quotes around the name are required.

The CURRent query returns the data that is presently in use, whether assigned by DHCP or statically. The STATic query returns the data that was assigned via the command. If the optional parameter is omitted from the query, the default is CURRent.

A power cycle may be required for this setting to take effect. This setting is stored in non-volatile memory.

Parameter	Typical Return
"<name>"	"ca.mycompany.com"

### **SYSTem:COMMunicate:LAN:GATEway "<address>"** **SYSTem:COMMunicate:LAN:GATEway? [CURRent | STATic]**

Assigns a default gateway to be used when DHCP is disabled. Note that the quotes around the address are required.

The CURRent query returns the data that is presently in use, whether assigned by DHCP or statically. The STATic query returns the data that was assigned via the command. If the optional parameter is omitted from the query, the default is CURRent.

A power cycle may be required for this setting to take effect. This setting is stored in non-volatile memory.

Parameter	Typical Return
"xxx.xxx.xxx.xxx"	"192.168.0.1"

### **SYSTem:COMMunicate:LAN:HOSTname "<name>"**

#### **SYSTem:COMMunicate:LAN:HOSTname? [CURRent | STATic]**

Assigns a hostname to the instrument. A hostname is the host portion of the full domain name, which is translated into an IP address. Note that the quotes around the name are required, and the name may be up to 15 characters.

The CURRent query returns the data that is presently in use. The STATic query returns the data that was assigned via the command. If the optional parameter is omitted from the query, the default is CURRent.

A power cycle may be required for this setting to take effect. This setting is stored in non-volatile memory.

Parameter	Typical Return
"<name>"	"K-DP5736A-83401"

### **SYSTem:COMMunicate:LAN:MAC?**

Returns the instrument's Media Access Control (MAC) address. This address is unique to the instrument. It is set at the factory and cannot be changed.

Parameter	Typical Return
(none)	"00-30-D3-1F-49-BD"

**SYSTem:COMMunicate:LAN:IPADdress "<address>"****SYSTem:COMMunicate:LAN:IPADdress? [CURRent | STATic]?**

Sets a static IP address to be used when DHCP is disabled. Note that the quotes around the address are required. If the optional parameter is omitted from the query, the default is CURRent.

A power cycle may be required for this setting to take effect. This setting is stored in non-volatile memory.

Parameter	Typical Return
"xxx.xxx.xxx.xxx"	"192.168.0.100"

**SYSTem:COMMunicate:LAN:SMASk "<mask>"****SYSTem:COMMunicate:LAN:SMASk? [CURRent | STATic]**

Sets a static subnet mask to be used when DHCP is disabled. Note that the quotes around the mask are required. If the optional parameter is omitted from the query, the default is CURRent.

A power cycle may be required for this setting to take effect. This setting is stored in non-volatile memory.

Parameter	Typical Return
"xxx.xxx.xxx.xxx"	"255.255.0.0"

**SYSTem:COMMunicate:RLState LOCAL|REMote|RWLock****SYSTem :COMMunicate:RLState?**

Configures the remote/local state of the instrument. LOCAL and REMote do the same thing and are included for compatibility with other products. Both allow front panel and remote control.

RWLock disables the front panel keys. Then the instrument can only be controlled remotely.

Parameter	Typical Return
LOCAL REMote RWLock, *RST LOCAL	LOC, REM, or RWL

Sets the remote/local state to remote: `SYST:COMM:RLST REM`

- The remote/local state is unaffected by \*RST or any SCPI commands other than SYSTem:COMMunicate:RLState.
- Also see the command SYSTem:KLOCK.

**SYSTem:DATE <year>, <month>, <day>****SYSTem:DATE?**

Sets the date of the real-time clock. Specify the year (2000 to 2099), month (1 to 12), and day (1 to 31).

The clock does not adjust itself for time zone changes or daylight savings time.

Parameter	Typical Return
<year>, <month>, <day>	+2025,+4,+30

**SYSTem:ERRor?**

Reads and clears one error from the Error Queue.

Parameter	Typical Return
(none)	<+0,"No error">

Reads and clear first error in error queue: SYST:ERR?

- The front-panel ERR annunciator turns on when one or more errors are currently stored in the error queue. Error retrieval is first-in-first-out (FIFO), and errors are cleared as you read them. When you have read all errors from the error queue, the ERR annunciator turns off.
- If more than 20 errors have occurred, the last error stored in the queue (the most recent error) is replaced with -350,"Error queue overflow". No additional errors are stored until you remove errors from the queue. If no errors have occurred when you read the error queue, the instrument responds with +0,"No error".
- The Error Queue is cleared by the \*CLS and when power is cycled. It is not cleared by a \*RST.
- Errors have the following format (the error string may contain up to 255 characters).  
<error code>,<error string> For a list of error codes and message strings, see SCPI Error Messages.

**SYSTem:KLOCK 0|OFF|1|ON****SYSTem:KLOCK?**

Keyboard lock – disables front panel control. When set to 1 or ON the instrument can only be controlled remotely. This command is nonvolatile, unlike SYST:COMM:RLST RWLock.

Parameter	Typical Return
0 OFF 1 ON, *RST OFF	0 or 1

**SYSTem:LiCense:DESCription? "<option name>"**

Returns a description of an option. The option does not need to be installed for this command to work.

Parameter	Typical Return
Option name enclosed in quotes	"Removable SD Memory Option"

Also see: [SCPI Commands Related to Option DP5705A](#)

**SYSTem:LiCense:INSTall "<license\_string>"**

Installs a licensed option, using a license string supplied by Keysight.

Parameter	Typical Return
License string, enclosed in quotes	(none)

Also see: [SCPI Commands Related to Option DP5705A](#)

**SYSTem:LiCense:INSTall? "<option name>"**

Indicates whether an option is installed.

Parameter	Typical Return
Option name, enclosed in quotes	0 or 1

Also see: [SCPI Commands Related to Option DP5705A](#)

**SYSTem:SECurity:IMMEDIATE**

Clears all user memory. This command is typically used to prepare the instrument for removal from a secure area. It sanitizes all user data stored in EEPROM and/or flash memory. Identification data (instrument firmware, model number, serial number, MAC address and calibration data) is not erased.

This procedure is not recommended for use in routine applications because of the possibility of unintended loss of data.

Parameter	Typical Return
(none)	(none)

Also see: [SCPI Commands Related to Option DP5705A](#)

**SYSTem:TIME <hour>,<minute>,<second>****SYSTem:TIME?**

Sets the time of the real-time clock. Specify the hour (0 to 23), minute (0 to 59), and second (0 to 59).

The clock does not adjust itself for time zone changes or daylight savings time.

Parameter	Typical Return
<hour>,<minute>,<second>	+15,+36,+12

**SYSTem:VERSion?**

Returns the SCPI version that the instrument complies with. Cannot be determined from front panel.

Parameter	Typical Return
(none)	<"version">

Return the SCPI version: SYST:VERS?

## Trigger Commands

Trigger commands control the remote triggering of the instrument's output list. Abort commands abort any pending triggers. Initiate commands initiate the trigger system.

### **TRIGger[:TRANsient][:IMMEDIATE]**

Generates an immediate trigger. This overrides any selected trigger source. Triggers affect the output lists.

Parameter	Typical Return
(none)	(none)
Generates a transient trigger: TRIG:TRAN	

- You must initiate the trigger system before you can send any trigger.
- When sent, the trigger will cause an output change as specified by the List commands.
- When the trigger sequence completes, the WTG-tran bit in the Status Operation Condition register is cleared.

### **TRIGger[:TRANsient]:SOURce BUS|IMMEDIATE|EXTERNAL**

#### **TRIGger[:TRANsient]:SOURce?**

Selects the trigger source.

Parameter	Typical Return
BUS	BUS
Example: TRIG:SOUR BUS	

## Voltage Commands

Voltage commands program the output voltage and voltage protection functions. The **SOURCE** keyword is optional in the following commands.

**[SOURCE:]VOLTage:ANALog:SOURCE OFF|VOLTage|RESistance**

**[SOURCE:]VOLTage:ANALog:SOURCE?**

Turns on or off analog programming of voltage, and selects the type of analog programming.

**OFF** – Voltage is controlled by SCPI or the front panel setting. Analog control is off.

**VOLTage** – Voltage is controlled by an analog voltage signal.

**RESistance** – Voltage is controlled by an analog resistance.

Parameter	Typical Return
OFF VOLTage RESistance, *RST OFF	OFF, VOLT, or RES

**[SOURCE:]VOLTage[:LEVel][:IMMediate][:AMPLitude] <volt>**

**[SOURCE:]VOLTage[:LEVel][:IMMediate][:AMPLitude]? [MIN|MAX]**

**[SOURCE:]VOLTage[:LEVel]:TRIGgered[:AMPLitude] <value>|MIN|MAX**

**[SOURCE:]VOLTage[:LEVel]:TRIGgered[:AMPLitude]? [MIN|MAX]**

Sets the immediate or triggered voltage level. The triggered level is the value that is transferred to the output when an output Step is triggered. Units are in volts. The maximum value depends on the voltage rating of the unit.

Parameter	Typical Return
0 to 105% of rating MIN MAX, *RST 0	<voltage level>
Sets the output voltage level to 20 V: <b>VOLT 20</b>	

**[SOURCE:]VOLTage:MODE FIXed|LIST|STEP**

**SOURCE:]VOLTage:MODE?**

Sets the transient mode. This determines what happens to the output voltage when the transient system is initiated and triggered. **FIXed** keeps the output voltage at its immediate value. **STEP** steps the output to the triggered level when a trigger occurs.

Parameter	Typical Return
FIXed LIST STEP, *RST FIXed	<FIX>

**[SOURce:]VOLTage:PROTection[:LEVel] <volt>|MIN|MAX****[SOURce:]VOLTage:PROTection[:LEVel]? [MIN|MAX]**

Sets the over-voltage protection level. Units are in volts. If the output voltage exceeds the OVP level, the output is disabled and the Questionable Condition status register OV bit is set.

Parameter	Typical Return
105% of voltage setting to 110% of voltage rating MIN MAX *RST 110% of voltage rating	<over-voltage level>
Sets the over-voltage protection to 60 V: VOLT:PROT 60	

- An over-voltage condition can be cleared with the OUTput:PROTection:CLEar command after the cause of the condition has been removed.

**[SOURce:]VOLTage:PROTection:LOW[:LEVel] <volt>|MIN|MAX****[SOURce:]VOLTage:PROTection:LOW[:LEVel]? [MIN|MAX]**

Sets the under-voltage protection level. Units are in volts. If under-voltage protection is enabled, and the output voltage goes below this level for more than the programmed delay time, the output is disabled and the Questionable Condition status register UV bit is set.

Parameter	Typical Return
0 to 95% of voltage setting	<under-voltage level>

**[SOURce:]VOLTage:PROTection:LOW:DELAy <time>|MIN|MAX****[SOURce:]VOLTage:PROTection:LOW:DELAy? [MIN|MAX]**

Sets the under-voltage protection delay time. Units are in seconds.

Parameter	Typical Return
0.1 to 25.5, *RST 0.1	<delay time>

**[SOURce:]VOLTage:PROTection:LOW:STATe 0|OFF|1|ON****[SOURce:]VOLTage:PROTection:LOW:STATe?**

Enables or disables under-voltage protection.

Parameter	Typical Return
0 OFF 1 ON, *RST OFF	0 or 1

**[SOURce:]VOLTage:RESistance[:LEVel][:IMMediate][:AMPLitude] <value>|MIN|MAX**

**[SOURce:]VOLTage:RESistance[:LEVel][:IMMediate][:AMPLitude]? [MIN|MAX]**

Sets the output resistance level. Only applies in constant voltage mode. Units are in ohms.

Parameter	Typical Return
0.001 to 1.0, *RST 0.001	<resistance level>

**[SOURce:]VOLTage:RESistance:STATe 0|OFF|1|ON**

**[SOURce:]VOLTage:RESistance:STATe?**

Enables or disables output resistance. Only applies in constant voltage mode.

Parameter	Typical Return
0 OFF 1 ON, *RST OFF	0 or 1

**[SOURce]:VOLTage:SENSe[:SOURce] LOCal|REMOte**

**[SOURce]:VOLTage:SENSe[:SOURce]?**

Selects local or remote voltage sensing.

**LOCal** – Output voltage is sensed and regulated at the output terminals.

**REMOte** – Output voltage is sensed and regulated at the sense terminals.

For compatibility, INTernal and EXTernal are also accepted in place of LOCal and REMote.

When remote sensing is in use, the REM indicator on the front panel is illuminated (see **Output Voltage Sensing**).

This setting is stored in non-volatile memory.

Parameter	Typical Return
LOCal INTernal REMOte EXTernal	LOC or REM

**[SOURce:]VOLTage:SLEW:POSitive[:IMMEDIATE] <slw>**

**[SOURce:]VOLTage:SLEW:NEGative[:IMMEDIATE] <slw>**

Sets the voltage slew rate. The slew rate is set in volts per second. The slew rate can be set to any value between 0.1 and 9.9999e+5. For very large values, the slew rate will be limited by the unit's listed programming speed and bandwidth. Keyword MAX sets the slew rate to maximum.

Parameter	Typical Return
0.1 to 9.9999e+5 MIN MAX, *RST MAX	<max value>
Sets the voltage slew rate to 5 V per second: <code>VOLT:SLEW 5</code>	

- The front panel displays the slew rate in volts per millisecond, rather than volts per second. Therefore the range of settings on the front panel is 0.0001 to 999.99.

## Reset State (\*RST)

**NOTE**

The power-on/reset state may differ from that shown below if you have enabled power-on state recall mode from the **States** menu (see [Instrument State Storage](#)).

The following commands are set to the indicated reset values at power-on or after \*RST.

SCPI Command *RST Settings	
CURRent	0
CURRent:MODE	FIXed
CURRent:PROTection:DELay	0.1 s
CURRent:PROTection:STATe	OFF
CURRent:TRIGgered	0
DISPlay	ON
OUTPut	OFF
TRIGger:TRANsient:SOURce	BUS
VOLTage	0
VOLTage:MODE	FIXed
VOLTage:PROTection	110% of rating
VOLTage:TRIGgered	0

The following as-shipped **non-volatile** parameter settings are not affected by power cycling or \*RST.

SCPI as-shipped non-volatile settings	
OUTPut:INH:MODE	OFF
OUTPut:PON:STATe	RST
SYSTem:KLOCK	OFF
Front Panel as-shipped settings	
GPIB address	5
Interface as-shipped settings	
Get IP Address	Automatic
IP Address	169.254.89.00
Subnet mask	255.255.0.0

## 5 SCPI Programming Reference

---

Default gateway	0.0.0.0
Host name	K-DP57xxx-xxxx
mDNS service name	K-DP57xxx-xxxx.local.
LAN service - VXI-11	Enabled
LAN service - Telnet	Enabled
LAN service - mDNS	Enabled
LAN service - Web server	Enabled
LAN service - sockets	Enabled
Web password	keysight

---

## SCPI Error Messages

The Keysight instrument returns error messages in accord with the SCPI standard.

- Up to 20 errors can be stored in each interface-specific error queue (one each for GPIB, USB, VXI-11, and Telnet/Sockets.) Errors appear in the error queue of the I/O session that caused the error.
- A special global error queue holds all power-on and hardware-related errors (for example, over-temperature).
- Error retrieval is first-in-first-out (FIFO), and errors are cleared as you read them. Once you have read all interface-specific errors, the errors in the global error queue are retrieved. When you have read all errors from the error queue, the ERR annunciator turns off.
- If more than 20 errors have occurred, the last error stored in the queue (the most recent error) is replaced with -350,"Error queue overflow". No additional errors are stored until you remove errors from the queue. If no errors have occurred when you read the error queue, the instrument responds with +0,"No error".
- The front panel reports errors from all I/O sessions and the global error queue.
- Error conditions are also summarized in the Status Byte Register. See [Status Subsystem Introduction](#) for details.
- The interface-specific error queues are cleared by power cycles and \*CLS. The error queue is not cleared by \*RST.
- **SCPI:**

`SYSTem:ERRor?` *Read and clear one error from the queue*

Errors have the following format (the error string may contain up to 255 characters):

-113,"Undefined header"

<b>Error</b>	<b>Device-dependent Errors (these errors set Standard Event Status register bit #3)</b>
0	<b>No error</b> This is the response to the ERR? query when there are no errors.
116	<b>Locked out by internal switch setting</b> This function has been locked out by an internal switch.
200	<b>Hardware error channel &lt;1&gt;</b> A hardware error has occurred on the output.
202	<b>Selftest Fail</b> A selftest failure has occurred. See selftest failure list for details.
209	<b>Internal communication error</b> An internal communication error has occurred in the instrument.
210	<b>Frame NVRAM error</b> A non-volatile RAM error has occurred in the instrument.
308	<b>This setting cannot be changed while transient trigger is initiated</b> Setting cannot be changed while the instrument is waiting for or executing a trigger sequence.
309	<b>Cannot initiate, voltage and current in fixed mode</b> Cannot initiate transient generator. Either the voltage or current function is set to Fixed mode.
315	<b>Settings conflict error</b> A data element could not be programmed because of the present instrument state.
317	<b>Invalid format</b> The saved state file is corrupted.
318	<b>Configuration error</b> A primary/secondary configuration error has occurred.
320	<b>Firmware update error</b> This may be due to the instrument hardware not being able to support the firmware version.

<b>Error</b>	<b>Command Errors (these errors set Standard Event Status register bit #5)</b>
-100	<b>Command error</b> Generic syntax error.
-101	<b>Invalid character</b> An invalid character was found in the command string.
-102	<b>Syntax error</b> Invalid syntax was found in the command string. Check for blank spaces.
-103	<b>Invalid separator</b> An invalid separator was found in the command string. Check for proper use of , ; :
-104	<b>Data type error</b> A different data type than the one allowed was found in the command string.
-105	<b>GET not allowed</b> A group execute trigger is not allowed in a command string.
-108	<b>Parameter not allowed</b> More parameters were received than were expected.
-109	<b>Missing parameter</b> Fewer parameters were received than were expected.
-110	<b>Command header error</b> An error was detected in the header.
-111	<b>Header separator error</b> A character that was not a valid header separator was found in the command string.
-112	<b>Program mnemonic too long</b> The header contains more than 12 characters.
-113	<b>Undefined header</b> A command was received that was not valid for this instrument.
-114	<b>Header suffix out of range</b> The value of the numeric suffix is not valid.
-120	<b>Numeric data error</b> Generic numeric data error.
-121	<b>Invalid character in number</b> An invalid character for the data type was found in the command string.
-123	<b>Exponent too large</b> The magnitude of the exponent was larger than 32000.
-124	<b>Too many digits</b> The mantissa of a numeric parameter contained more than 255 digits, excluding leading zeros.
-128	<b>Numeric data not allowed</b> A numeric parameter was received but a character string was expected.
-131	<b>Invalid suffix</b> A suffix was incorrectly specified for a numeric parameter.
-134	<b>Suffix too long</b> The suffix contains more than 12 characters.
-138	<b>Suffix not allowed</b> A suffix is not supported for this command.
-140	<b>Character data error</b> Generic character data error
-141	<b>Invalid character data</b> Either the character data element contains an invalid character, or the element is not valid.
-144	<b>Character data too long</b> The character data element contains more than 12 characters.

<b>Error</b>	<b>Command Errors (these errors set Standard Event Status register bit #5)</b>
-148	<b>Character data not allowed</b> A discrete parameter was received, but a string or numeric parameter was expected.
-150	<b>String data error</b> Generic string data error
-151	<b>Invalid string data</b> An invalid character string was received. Check that the string is enclosed in quotation marks.
-158	<b>String data not allowed</b> A character string was received, but is not allowed for this command.

<b>Error</b>	<b>Execution Errors (these errors set Standard Event Status register bit #4)</b>
-200	<b>Execution error</b> Generic syntax error
-220	<b>Parameter error</b> A data element related error occurred.
-221	<b>Settings conflict</b> A data element could not be executed because of the present instrument state.
-222	<b>Data out of range</b> A data element could not be executed because the value was outside the valid range.
-223	<b>Too much data</b> A data element was received that contains more data than the instrument can handle.
-224	<b>Illegal parameter value</b> An exact value was expected but not received.
-225	<b>Out of memory</b> The device has insufficient memory to perform the requested operation.
-230	<b>Data corrupt or stale</b> Possible invalid data. A new reading was started but not completed.
-231	<b>Data questionable</b> The measurement accuracy is suspect.
-232	<b>Invalid format</b> The data format or structure is inappropriate.
-233	<b>Invalid version</b> The version of the data format is incorrect to the instrument.
-240	<b>Hardware error</b> The command could not be executed because of a hardware problem with the instrument.
-241	<b>Hardware missing</b> The command could not be executed because of missing hardware, such as an option.

<b>Error</b>	<b>Query Errors (these errors set Standard Event Status register bit #2)</b>
-400	<b>Query Error</b> Generic error query
-410	<b>Query INTERRUPTED</b> A condition causing an interrupted query error occurred.
-420	<b>Query UNTERMINATED</b> A condition causing an unterminated query error occurred.
-430	<b>Query DEADLOCKED</b> A condition causing a deadlocked query error occurred.
-440	<b>Query UNTERMINATED after indefinite response</b> A query was received in the same program message after a query indicating an indefinite response was executed.



# 6

## Option DP5705A (SD Card Option)

**Option DP5705A Description**

**Option Installation**

**Basic Operation**

**SD Card Data Storage**

**SD Card Insertion and Removal**

**Option DP5705A Behavior When a Blank Card is First Inserted**

**Option DP5705A Behavior When No SD Card is Installed**

**Option DP5705A Behavior When SD Card is Used Incorrectly**

**SCPI Commands Related to Option DP5705A**

### Option DP5705A Description

Option DP5705A is a user-installed option for the Keysight DP5700 series of power supplies. This option writes sensitive user data to a micro-SD card, rather than internal memory. The card is accessible on the back of the unit, allowing for easy removal and sanitization.

### Option Installation

The option is installed by sending a SCPI command containing a license string to the unit. The command may be sent via any of the programming interfaces – LAN, USB, or GPIB. Complete installation instructions, including the SCPI command and license string, are supplied when the license is purchased. Note that the license string is specific to the particular unit for which the license was purchased.

Once the DP5705A option is installed, it cannot be removed by the user.

### Basic Operation

The SD card is user-supplied, and must be formatted with the FAT32 file system. Cards formatted with exFAT or NTFS will not work. Keysight strongly recommends the use of a high-quality, name brand micro-SD card (such as PNY, Sandisk, or Kingston).

The power supply creates a folder on the SD card called KeysightNonvolatileData, and stores all its data in that folder. No other data should be stored in that folder.

The SD card must be inserted prior to powering the unit. Removing or inserting an SD card while the unit is in operation will require rebooting the unit, and could cause data corruption.

An SD card is reserved for use by the specific power supply in which it is installed. Moving the SD card to a unit with a different model number or serial number will generate errors, unless the KeysightNonvolatileData folder is first erased from the card.

## SD Card Data Storage

The following data is stored on the SD card:

- All Instrument states (from 0 to 9) stored with the **\*SAV** command.
- Nonvolatile configuration, including:
  - Calibration passcode.
  - Digital I/O connector configuration.
- User preferences, including:
  - Screen saver settings.
  - Power on settings (reset or saved state).

The following data remains in the power supply's internal memory:

- Model number and serial number.
- Installed options.
- Calibration data and calibration count.
- LAN parameters.

## SD Card Insertion and Removal

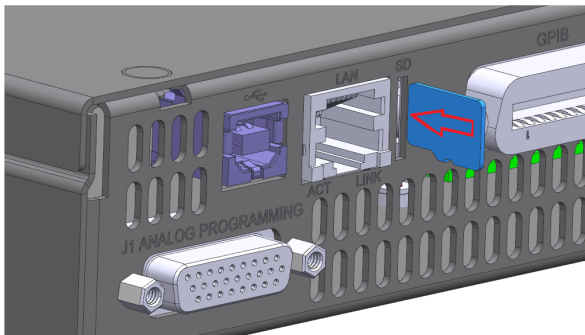

### To Insert MicroSD Memory Card

1. Make sure the product is turned off.
2. Insert MicroSD into the slot above the LAN connector.
3. Gently push the card into the socket until it locks in place.

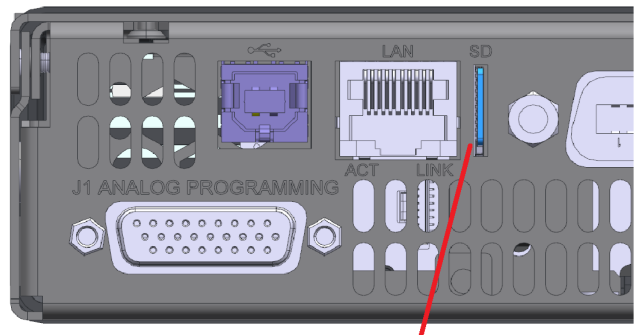

### To Remove MicroSD Memory Card

1. Make sure the product is turned off.
2. Gently press the card in to unlock it from the socket.
3. Pull the card out.
4. Store the card in a safe place until the unit is returned for use.

## Option DP5705A Behavior When a Blank Card is First Inserted

The SD card must be formatted with FAT32 and be ready to accept files. Ideally it should not contain any files. The card should be inserted with the power off; then the power switch should be turned on. Errors will be placed in the SCPI error queue because the power supply needs to write initial files to the card. These errors will be returned in response to the SYSTem:ERRor command. When power is cycled again, no errors should appear.

## Option DP5705A Behavior When No SD Card is Installed

It is best to always operate the unit with an SD card installed. If the card is removed for security purposes, another blank card should be inserted before continuing operation. Without an SD card, the behavior is as follows:

- At power-on an “SD card missing” error will be placed in the SCPI error queue. This error will be returned in response to the SYSTem:ERRor command.
- Most SCPI commands will behave normally, except that some data that would normally be stored in nonvolatile memory now becomes volatile (it reverts to the default values when power is cycled). Refer to the parameters listed under “SD Card Data Storage”.
- The **\*SAV** and **\*RCL** commands will not operate and will produce errors.
- Calibration is possible, and the calibration data will be stored in nonvolatile memory in the power supply’s internal memory. As the calibration passcode is stored on the SD card, without a card the passcode reverts to its default value of 0 (zero).

## Option DP5705A Behavior When SD Card is Used Incorrectly

- If a card is inserted or removed while the power supply is powered on, errors will result, and data could be corrupted.
- If a card is moved from one power supply to another without first deleting the Key-sightNonvolatileData folder, errors will result.

## SCPI Commands Related to Option DP5705A

SCPI Command	Description
<b>SYSTem:LIcense:INSTall "&lt;license_string&gt;"</b>	Installs the option.
<b>SYSTem:LIcense:INSTall? "DP5705A"</b>	Returns 1 if the option is installed, 0 otherwise.
<b>SYSTem:LIcense:DESCription? "DP5705A"</b>	Returns "Removable SD Memory Option".
<b>*OPT?</b>	With option installed, returns DP5705A.
<b>SYSTem:SECurity:IMMediate</b>	Deletes any user data that may have been stored in internal memory before the option was installed. Has no effect on data stored on the SD card.

# 7

## Specifications and Characteristics

### Specifications

### Supplemental Characteristics

### Common Characteristics

### Dimension Diagrams

This chapter lists the specifications and supplemental characteristics of the Keysight DP5700 power supplies. A dimensional line drawing of the unit is included at the end of the chapter.

Unless otherwise noted, specifications are warranted over the ambient temperature range of 0 to 40° C, after a 30-minute warm-up period.

Sensing is at the rear terminals of the power supply. Sense terminals are externally jumpered to their respective output terminals, and local or remote voltage sensing is selected (see **Output Voltage Sensing**).

Supplemental characteristics are not warranted but are descriptions of typical performance determined either by design or type testing.

## Specifications

**Specifications for 1.5 kW Models**

**Specifications for 3.4 kW Models**

**Specifications for 5 kW Models**

## Specifications for 1.5 kW Models

Model	DP5721A	DP5722A	DP5723A	DP5724A	DP5726A	DP5728A	DP5730A	DP5731A	DP5733A	DP5736A
<b>DC Power Ratings</b>										
Voltage	0 - 10 V	0 - 20 V	0 - 30 V	0 - 40 V	0 - 60 V	0 - 80 V	0 - 100 V	0 - 150 V	0 - 300 V	0 - 600 V
Current	0 - 150 A	0 - 75 A	0 - 50 A	0 - 38 A	0 - 25 A	0 - 19 A	0 - 15 A	0 - 10 A	0 - 5 A	0 - 2.6 A
Power	1.5 kW	1.5 kW	1.5 kW	1.52 kW	1.5 kW	1.52 kW	1.5 kW	1.5 kW	1.5 kW	1.56 kW
<b>Output ripple and noise<sup>1</sup></b>										
CV rms:	6 mV	6 mV	6 mV	7 mV	7 mV	8 mV	30 mV	20 mV	45 mV	100 mV
CV peak-to-peak:	50 mV	50 mV	50 mV	60 mV	60 mV	75 mV	130 mV	75 mV	180 mV	500 mV
<b>Load Regulation</b>										
Voltage	3 mV	4 mV	5 mV	6 mV	8 mV	10 mV	12 mV	17 mV	32 mV	62 mV
Current	35 mA	20 mA	15 mA	12.6 mA	10 mA	8.8 mA	8 mA	7 mA	6 mA	5.52 mA
<b>Line Regulation</b>										
Voltage	1 mV	2 mV	3 mV	4 mV	6 mV	8 mV	10 mV	15 mV	30 mV	60 mV
Current	17 mA	9.5 mA	7 mA	5.8 mA	4.5 mA	3.9 mA	3.5 mA	3 mA	2.5 mA	2.26 mA
<b>Voltage programming accuracy<sup>2</sup></b>										
Voltage	5 mV	10 mV	15 mV	20 mV	30 mV	40 mV	50 mV	75 mV	150 mV	300 mV
<b>Current programming accuracy<sup>2,3</sup></b>										
Current	0.1%+300 mA	0.1%+150 mA	0.1%+100 mA	0.1%+76 mA	0.1%+50 mA	0.1%+38 mA	0.1%+30 mA	0.1%+20 mA	0.1%+10 mA	0.1%+5.2 mA
<b>Voltage measurement accuracy<sup>2</sup></b>										
Voltage	5 mV	10 mV	15 mV	20 mV	30 mV	40 mV	50 mV	75 mV	150 mV	300 mV
<b>Current measurement accuracy<sup>2</sup></b>										
Current	300 mA	150 mA	100 mA	76 mA	50 mA	38 mA	30 mA	20 mA	10 mA	5.2 mA
<b>Transient response<sup>4</sup></b>										
Recovery Time	≤ 1 ms	≤ 1 ms	≤ 1 ms	≤ 1 ms	≤ 1 ms	≤ 1 ms	≤ 1 ms	≤ 2 ms	≤ 2 ms	≤ 2 ms
Settling band	0.1 V	0.2 V	0.3 V	0.4 V	0.6 V	0.8 V	1 V	1.5 V	3 V	6 V

<sup>1</sup> From 5 Hz to 1 MHz for rms noise; from 20 Hz to 20 MHz for peak-to-peak noise

<sup>2</sup> Accuracy specifications are warranted at 23° C ±5° C

<sup>3</sup> Percent of programmed value + offset.

<sup>4</sup> Time for output voltage to recover within the settling band for a load change from 10% to 90% and 90% to 10% of its rated output current

## Specifications for 3.4 kW Models

Model	DP5741AS	DP5742AS	DP5743AS	DP5744AS	DP5746AS	DP5748AS	DP5750AS	DP5751AS	DP5753AS	DP5756AS
	DP5741AL	DP5742AL	DP5743AL	DP5744AL	DP5746AL	DP5748AL	DP5750AL	DP5751AL	DP5753AL	DP5756AL
	DP5741AH	DP5742AH	DP5743AH	DP5744AH	DP5746AH	DP5748AH	DP5750AH	DP5751AH	DP5753AH	DP5756AH
<b>DC Power Ratings</b>										
Voltage	0 to 10 V	0 to 20 V	0 to 30 V	0 to 40 V	0 to 60 V	0 to 80 V	0 to 100 V	0 to 150 V	0 to 300 V	0 to 600 V
Current	0 to 340 A	0 to 170 A	0 to 112 A	0 to 85 A	0 to 56 A	0 to 42 A	0 to 34 A	0 to 22.5 A	0 to 11.5 A	0 to 5.6 A
Power	3400 W	3400 W	3360 W	3400 W	3360 W	3360 W	3400 W	3375 W	3450 W	3360 W
<b>Output ripple and noise<sup>1</sup></b>										
CV rms:	8 mV	10 mV	10 mV	12 mV	15 mV	15 mV	15 mV	20 mV	60 mV	100 mV
CV peak-to-peak:	75 mV	75 mV	75 mV	75 mV	80 mV	80 mV	100 mV	120 mV	200 mV	480 mV
<b>Load Regulation</b>										
Voltage	6 mV	7 mV	8 mV	9 mV	11 mV	13 mV	15 mV	20 mV	35 mV	65 mV
Current	272 mA	136 mA	89.6 mA	68 mA	44.8 mA	33.6 mA	27.2 mA	18 mA	9.2 mA	4.48 mA
<b>Line Regulation</b>										
Voltage	1 mV	2 mV	3 mV	4 mV	6 mV	8 mV	10 mV	15 mV	30 mV	60 mV
Current	170 mA	85 mA	56 mA	42.5 mA	28 mA	21 mA	17 mA	11.25 mA	5.75 mA	2.8 mA
<b>Voltage programming accuracy<sup>2</sup></b>										
Voltage	5 mV	10 mV	15 mV	20 mV	30 mV	40 mV	50 mV	75 mV	150 mV	300 mV
<b>Current programming accuracy<sup>2,3</sup></b>										
Current	0.1%+680mA	0.1%+340mA	0.1%+224mA	0.1%+170mA	0.1%+112mA	0.1%+84 mA	0.1%+68 mA	0.1%+45 mA	0.1%+23 mA	0.1%+11.2mA
<b>Voltage measurement accuracy<sup>2</sup></b>										
Voltage	5 mV	10 mV	15 mV	20 mV	30 mV	40 mV	50 mV	75 mV	150 mV	300 mV
<b>Current measurement accuracy<sup>2</sup></b>										
Current	680 mA	340 mA	224 mA	170 mA	112 mA	84 mA	68 mA	45 mA	23 mA	11.2 mA
<b>Transient response<sup>4</sup></b>										
Recovery Time	1 ms	1 ms	1 ms	1 ms	1 ms	1 ms	1 ms	2 ms	2 ms	2 ms
Settling band	0.05 V	0.1 V	0.15 V	0.2 V	0.3 V	0.4 V	0.5 V	0.75 V	1.5 V	3 V

<sup>1</sup> From 5 Hz to 1 MHz for rms noise; from 20 Hz to 20 MHz for peak-to-peak noise

<sup>2</sup> Accuracy specifications are warranted at 23° C ±5° C

<sup>3</sup> Percent of programmed value + offset

<sup>4</sup> Time for output voltage to recover within the settling band for a load change from 10% to 90% and 90% to 10% of its rated output current

## Specifications for 5 kW Models

Model	DP5761AL DP5761AH	DP5762AL DP5762AH	DP5763AL DP5763AH	DP5764AL DP5764AH	DP5765AL DP5765AH	DP5766AL DP5766AH	DP5768AL DP5768AH
<b>DC Power Ratings</b>							
Voltage	0 to 10 V	0 to 20 V	0 to 30 V	0 to 40 V	0 to 50 V	0 to 60 V	0 to 80 V
Current	0 to 500 A	0 to 250 A	0 to 170 A	0 to 125 A	0 to 100 A	0 to 85 A	0 to 65 A
Power	5000 W	5000 W	5100 W	5000 W	5000 W	5100 W	5200 W
<b>Output ripple and noise<sup>1</sup></b>							
CV rms:	8 mV	10 mV	12 mV	12 mV	12 mV	12 mV	15 mV
CV peak-to-peak:	75 mV	75 mV	75 mV	75 mV	75 mV	75 mV	80 mV
<b>Load Regulation</b>							
Voltage	6 mV	7 mV	8 mV	9 mV	10 mV	11 mV	13 mV
Current	400 mA	200 mA	136 mA	100 mA	80 mA	68 mA	52 mA
<b>Line Regulation</b>							
Voltage	1 mV	2 mV	3 mV	4 mV	5 mV	6 mV	8 mV
Current	250 mA	125 mA	85 mA	62.5 mA	50 mA	42.5 mA	32.5 mA
<b>Voltage programming accuracy<sup>2</sup></b>							
Voltage	5 mV	10 mV	15 mV	20 mV	25 mV	30 mV	40 mV
<b>Current programming accuracy<sup>2,3</sup></b>							
Current	0.1%+1000 mA	0.1%+500 mA	0.1%+340 mA	0.1%+250 mA	0.1%+200 mA	0.1%+170 mA	0.1%+130 mA
<b>Voltage measurement accuracy<sup>2</sup></b>							
Voltage	5 mV	10 mV	15 mV	20 mV	25 mV	30 mV	40 mV
<b>Current measurement accuracy<sup>2</sup></b>							
Current	1000 mA	500 mA	340 mA	250 mA	200 mA	170 mA	130 mA
<b>Transient response<sup>4</sup></b>							
Recovery Time	1 ms	1 ms	1 ms	1 ms	1 ms	1 ms	1 ms
Settling band	0.05 V	0.1 V	0.15 V	0.2 V	0.25 V	0.3 V	0.4

<sup>1</sup> From 5 Hz to 1 MHz for rms noise; from 20 Hz to 20 MHz for peak-to-peak noise

<sup>2</sup> Accuracy specifications are warranted at 23° C ±5° C

<sup>3</sup> Percent of programmed value + offset.

<sup>4</sup> Time for output voltage to recover within the settling band for a load change from 10% to 90% and 90% to 10% of its rated output current

## Specifications for 5 kW Models

Model	DP5770AL DP5770AH	DP5771AL DP5771AH	DP5772AL DP5772AH	DP5773AL DP5773AH	DP5774AL DP5774AH	DP5775AL DP5775AH	DP5776AL DP5776AH
<b>DC Power Ratings</b>							
Voltage	0 to 100 V	0 to 150 V	0 to 200 V	0 to 300 V	0 to 400 V	0 to 500 V	0 to 600 V
Current	0 to 50 A	0 to 34 A	0 to 25 A	0 to 17 A	0 to 13 A	0 to 10 A	0 to 8.5 A
Power	5000 W	5100 W	5000 W	5100 W	5200 W	5000 W	5100 W
<b>Output ripple and noise<sup>1</sup></b>							
CV rms:	15 mV	20 mV	45 mV	60 mV	80 mV	80 mV	100 mV
CV peak-to-peak:	90 mV	120 mV	200 mV	200 mV	400 mV	450 mV	480 mV
<b>Load Regulation</b>							
Voltage	15 mV	20 mV	25 mV	35 mV	45 mV	55 mV	65 mV
Current	40 mA	27.2 mA	20 mA	13.6 mA	10.4 mA	8 mA	6.8 mA
<b>Line Regulation</b>							
Voltage	10 mV	15 mV	20 mV	30 mV	40 mV	50 mV	60 mV
Current	25 mA	17 mA	12.5 mA	8.5 mA	6.5 mA	5 mA	4.25 mA
<b>Voltage programming accuracy<sup>2</sup></b>							
Voltage	50 mV	75 mV	100 mV	150 mV	200 mV	250 mV	300 mV
<b>Current programming accuracy<sup>2,3</sup></b>							
Current	0.1%+100 mA	0.1%+68 mA	0.1%+50 mA	0.1%+34 mA	0.1%+26 mA	0.1%+20 mA	0.1%+17 mA
<b>Voltage measurement accuracy<sup>2</sup></b>							
Voltage	50 mV	75 mV	100 mV	150 mV	200 mV	250 mV	300 mV
<b>Current measurement accuracy<sup>2</sup></b>							
Current	100 mA	68 mA	50 mA	34 mA	26 mA	20 mA	17 mA
<b>Transient response<sup>4</sup></b>							
Recovery Time	1 ms	2 ms	2 ms	2 ms	2 ms	2 ms	2 ms
Settling band	0.5 V	0.75 V	1 V	1.5 V	2 V	2.5 V	3 V

<sup>1</sup> From 5 Hz to 1 MHz for rms noise; from 20 Hz to 20 MHz for peak-to-peak noise

<sup>2</sup> Accuracy specifications are warranted at 23° C ±5° C

<sup>3</sup> Percent of programmed value + offset.

<sup>4</sup> Time for output voltage to recover within the settling band for a load change from 10% to 90% and 90% to 10% of its rated output current

## Supplemental Characteristics

**Supplemental Characteristics for 1.5 kW Models**

**Supplemental Characteristics for 3.4 kW Models**

**Supplemental Characteristics for 5 kW Models**

## Supplemental Characteristics for 1.5 kW Models Keysight Models DP5721A – DP5736A

Model	DP5721A	DP5722A	DP5723A	DP5724A	DP5726A	DP5728A	DP5730A	DP5731A	DP5733A	DP5736A
<b>Output Response Time</b>										
Up, full load	20 ms	20 ms	20 ms	20 ms	20 ms	20 ms	20 ms	30 ms	30 ms	40 ms
Down, full load	20 ms	20 ms	20 ms	30 ms	30 ms	50 ms	50 ms	60 ms	70 ms	80 ms
Down, no load	300 ms	500 ms	600 ms	900 ms	1200 ms	1300 ms	1700 ms	2200 ms	2700 ms	3000 ms
<b>Remote Sense Compensation/Wire<sup>1</sup> (V)</b>										
	2	2	5	5	5	5	5	5	5	5
<b>Over-voltage protection accuracy</b>										
	0.1 V	0.2 V	0.3 V	0.4 V	0.6 V	0.8 V	1 V	1.5 V	3 V	6 V
<b>Over-voltage protection range</b>										
	0.5-12 V	1-24 V	2-36 V	2-44.1 V	5-66.15 V	5-88.2 V	5-110.25 V	5-165.37 V	5-330.75 V	5-661.5 V
<b>Output ripple and noise<sup>2</sup></b>										
(1-Phase)	<=250 mA	<=130 mA	<= 100 mA	<=60 mA	<=50 mA	<=30 mA	<=40 mA	<=10 mA	<=8 mA	<=5 mA
<b>Programming resolution</b>										
Voltage	0.2 mV	0.4 mV	0.6 mV	0.8 mV	1.2 mV	1.6 mV	2 mV	3 mV	6 mV	12 mV
Current	3.75 mA	1.875 mA	1.25 mA	0.95 mA	0.625 mA	0.475 mA	0.375 mA	0.25 mA	0.125 mA	0.065 mA
<b>Measurement resolution</b>										
Voltage	1.1 mV	1.2 mV	1.2 mV	1.2 mV	1.2 mV	1.6 mV	11 mV	10.5 mV	12 mV	12 mV
Current	15 mA	1.5 mA	1.5 mA	1.14 mA	1.25 mA	1.14 mA	1.05 mA	1.5 mA	0.15 mA	0.104 mA
<b>Front panel display accuracy (4 digits +/-1 count)</b>										
Voltage	5 mV	10 mV	15 mV	20 mV	30 mV	40 mV	50 mV	75 mV	150 mV	300 mV
Current	300 mA	150 mA	100 mA	76 mA	50 mA	38 mA	30 mA	20 mA	10 mA	5.2 mA
<b>Temperature stability<sup>3</sup></b>										
Voltage	1 mV	2 mV	3 mV	4 mV	6 mV	8 mV	10 mV	15 mV	30 mV	60 mV
Current	15 mA	7.5 mA	5 mA	3.8 mA	2.5 mA	1.9 mA	1.5 mA	1 mA	0.5 mA	0.26 mA
<b>Temperature Coefficient (ppm/C)<sup>4</sup></b>										
Voltage	50	50	50	50	50	50	50	50	50	50
Current	100	100	100	100	100	100	100	70	70	70
<b>Warm-up drift<sup>5</sup></b>										
Voltage	3 mV	4 mV	5 mV	6 mV	8 mV	10 mV	12 mV	32 mV	62 mV	122 mV
Current	375 mA	187.5 mA	125 mA	95 mA	62.5 mA	47.5 mA	37.5 mA	15 mA	7.5 mA	3.9 mA

<sup>1</sup> The maximum voltage on the power supply terminals must not exceed the rated voltage.

<sup>2</sup> From 5 Hz to 1 MHz for rms noise.

<sup>3</sup> Temperature stability applies over 8hrs interval following 30 minutes warm-up. Constant line, load & temperature.

<sup>4</sup> Temperature coefficient applies following 30 minute warm up period.

<sup>5</sup> Warm up drift occurs during 30 minute period following power on as noted in footnotes 3 & 4.

## Supplemental Characteristics for 3.4 kW Models

### Keysight Models DP5741AS – DP5756AS, DP5741AL – DP5756AL, and DP5741AH – DP5756AH

Model	DP5741AS	DP5742AS	DP5743AS	DP5744AS	DP5746AS	DP5748AS	DP5750AS	DP5751AS	DP5753AS	DP5756AS
	DP5741AL	DP5742AL	DP5743AL	DP5744AL	DP5746AL	DP5748AL	DP5750AL	DP5751AL	DP5753AL	DP5756AL
	DP5741AH	DP5742AH	DP5743AH	DP5744AH	DP5746AH	DP5748AH	DP5750AH	DP5751AH	DP5753AH	DP5756AH
<b>Output Response Time</b>										
Up, full load	30 ms	30 ms	30 ms	30 ms	50 ms	50 ms	50 ms	50 ms	50 ms	100 ms
Down, full load	50 ms	50 ms	80 ms	80 ms	80 ms	100 ms	100 ms	100 ms	100 ms	200 ms
Down, no load	450 ms	600 ms	800 ms	900 ms	1100 ms	1300 ms	2100 ms	2000 ms	3200 ms	3100 ms
<b>Remote Sense Compensation/Wire<sup>1</sup> (V)</b>										
	2	2	5	5	5	5	5	5	5	5
<b>Over-voltage protection accuracy</b>										
	0.1 V	0.2 V	0.3 V	0.4 V	0.6 V	0.8 V	1 V	1.5 V	3 V	6 V
<b>Over-voltage protection range</b>										
	0.5-12 V	1-24 V	2-36 V	2-44.1 V	5-66.15 V	5-88.2 V	5-110.25 V	5-165.37 V	5-330.75 V	5-661.5 V
<b>Output ripple and noise<sup>2</sup></b>										
(3-Phase)	<=800 mA	<=450 mA	<=300 mA	<=150 mA	<=100 mA	<=70 mA	<=45 mA	<=30 mA	<=12 mA	<=5 mA
(1-Phase)	<=1200 mA	<=600 mA	<=300 mA	<=300 mA	<=200 mA	<=100 mA	<=60 mA	<=40 mA	<=12 mA	<=8 mA
<b>Programming resolution</b>										
Voltage	0.2 mV	0.4 mV	0.6 mV	0.8 mV	1.2 mV	1.6 mV	2 mV	3 mV	6 mV	12 mV
Current	6.8 mA	3.4 mA	2.24 mA	1.7 mA	1.12 mA	0.85 mA	0.68 mA	0.45 mA	0.23 mA	0.112 mA
<b>Measurement resolution</b>										
Voltage	1.1 mV	1.2 mV	1.2 mV	1.2 mV	1.2 mV	1.6 mV	11 mV	10.5 mV	12 mV	12 mV
Current	1.36 mA	1.19 mA	1.12 mA	1.7 mA	1.68 mA	1.68 mA	1.36 mA	1.35 mA	1.15 mA	0.168 mA
<b>Front panel display accuracy (4 digits +/-1 count)</b>										
Voltage	5 mV	10 mV	15 mV	20 mV	30 mV	40 mV	50 mV	75 mV	150 mV	300 mV
Current	680 mA	340 mA	224 mA	170 mA	112 mA	84 mA	68 mA	45 mA	23 mA	11.2 mA
<b>Temperature stability<sup>3</sup></b>										
Voltage	1 mV	2 mV	3 mV	4 mV	6 mV	8 mV	10 mV	15 mV	30 mV	60 mV
Current	3.4 mA	17 mA	11.2 mA	8.5 mA	5.6 mA	4.2 mA	3.4 mA	2.25 mA	1.15 mA	0.56 mA
<b>Temperature Coefficient (ppm/C)<sup>4</sup></b>										
Voltage	50	50	50	50	50	50	50	50	50	50
Current	100	100	100	100	100	100	100	70	70	70
<b>Warm-up drift<sup>5</sup></b>										
Voltage	7 mV	12 mV	17 mV	22 mV	32 mV	42 mV	52 mV	77 mV	152 mV	302 mV
Current	85 mA	425 mA	280 mA	212.5 mA	140 mA	105 mA	85 mA	33.75 mA	17.25 mA	8.4 mA

<sup>1</sup> The maximum voltage on the power supply terminals must not exceed the rated voltage.

<sup>2</sup> From 5 Hz to 1 MHz for rms noise.

<sup>3</sup> Temperature stability applies over 8hrs interval following 30 minutes warm-up. Constant line, load & temperature.

<sup>4</sup> Temperature coefficient applies following 30 minute warm up period.

<sup>5</sup> Warm up drift occurs during 30 minute period following power on as noted in footnotes 3 & 4.

## Supplemental Characteristics for 5 kW Models

### Keysight Models DP5761AL – DP5768AL and DP5761AH – DP5768AH

Model	DP5761AL DP5761AH	DP5762AL DP5762AH	DP5763AL DP5763AH	DP5764AL DP5764AH	DP5765AL DP5765AH	DP5766AL DP5766AH	DP5768AL DP5768AH
<b>Output Response Time</b>							
Up, full load	30 mS	30 mS	30 mS	30 mS	50 mS	50 mS	50 mS
Down, full load	50 mS	50 mS	80 mS	80 mS	80 mS	80 mS	100 mS
Down, no load	300 mS	600 mS	800 mS	900 mS	950 mS	1000 mS	1200 mS
<b>Remote Sense Compensation/Wire<sup>1</sup> (V)</b>							
	2	2	5	5	5	5	5
<b>Over-voltage protection accuracy</b>							
	0.1 V	0.2 V	0.3 V	0.4 V	0.5 V	0.6 V	0.8 V
<b>Over-voltage protection range</b>							
	0.5-12 V	1-24 V	2-36 V	2-44.1 V	5-55.125 V	5-66.15 V	5-88.2 V
<b>Output ripple and noise<sup>2</sup></b>							
(3-Phase)	<=1200 mA	<=600 mA	<=300 mA	<=150 mA	<=130 mA	<= 100 mA	<=70 mA
<b>Programming resolution</b>							
Voltage	0.2 mV	0.4 mV	0.6 mV	0.8 mV	1 mV	1.2 mV	1.6 mV
Current	10 mA	5 mA	3.4 mA	2.5 mA	2 mA	1.7 mA	1.3 mA
<b>Measurement resolution</b>							
Voltage	1.1 mV	1.2 mV	1.2 mV	1.2 mV	1.5 mV	1.2 mV	1.6 mV
Current	15 mA	12.5 mA	10.2 mA	11.25 mA	11 mA	1.7 mA	1.3 mA
<b>Front panel display accuracy (4 digits +/-1 count)</b>							
Voltage	5 mV	10 mV	15 mV	20 mV	25 mV	30 mV	40 mV
Current	1000 mA	500 mA	340 mA	250 mA	200 mA	170 mA	130 mA
<b>Temperature stability<sup>3</sup></b>							
Voltage	1 mV	2 mV	3 mV	4 mV	5 mV	6 mV	8 mV
Current	50 mA	25 mA	17 mA	12.5 mA	10 mA	8.5 mA	6.5 mA
<b>Temperature Coefficient (ppm/C)<sup>4</sup></b>							
Voltage	50	50	50	50	50	50	50
Current	100	100	100	100	100	100	100
<b>Warm-up drift<sup>5</sup></b>							
Voltage	7 mV	12 mV	17 mV	22 mV	27 mV	32 mV	42 mV
Current	1250 mA	625 mA	425 mA	312.5 mA	250 mA	212.5 mA	162.5 mA

<sup>1</sup> The maximum voltage on the power supply terminals must not exceed the rated voltage.

<sup>2</sup> From 5 Hz to 1 MHz for rms noise.

<sup>3</sup> Temperature stability applies over 8hrs interval following 30 minutes warm-up. Constant line, load & temperature.

<sup>4</sup> Temperature coefficient applies following 30 minute warm up period.

<sup>5</sup> Warm up drift occurs during 30 minute period following power on as noted in footnotes 3 & 4.

## Supplemental Characteristics for 5 kW Models

### Keysight Models DP5770AL – DP5776AL and DP5770AH – DP5776AH

Model	DP5770AL DP5770AH	DP5771AL DP5771AH	DP5772AL DP5772AH	DP5773AL DP5773AH	DP5774AL DP5774AH	DP5775AL DP5775AH	DP5776AL DP5776AH
<b>Output Response Time</b>							
Up, full load	50 mS	50 mS	50 mS	50 mS	100 mS	100 mS	100 mS
Down, full load	100 mS	100 mS	100 mS	100 mS	150 mS	200 mS	200 mS
Down, no load	1900 mS	2000 mS	2000 mS	3000 mS	4000 mS	4000 mS	3000 mS
<b>Remote Sense Compensation/Wire<sup>1</sup> (V)</b>							
	5	5	5	5	5	5	5
<b>Over-voltage protection accuracy</b>							
	1 V	1.5 V	2 V	3 V	4 V	5 V	6 V
<b>Over-voltage protection range</b>							
	5-110.25 V	5-165.37 V	5-220.5 V	5-330.75 V	5-441 V	5-551.25 V	5-661.5 V
<b>Output ripple and noise<sup>2</sup></b>							
(3-Phase)	<=45 mA	<=45 mA	<=45 mA	<=15 mA	<=12 mA	<=10 mA	<=8 mA
<b>Programming resolution</b>							
Voltage	2 mV	3 mV	4 mV	6 mV	8 mV	10 mV	12 mV
Current	1 mA	0.68 mA	0.5 mA	0.34 mA	0.26 mA	0.2 mA	0.17 mA
<b>Measurement resolution</b>							
Voltage	11 mV	10.5 mV	10 mV	12 mV	12 mV	15 mV	12 mV
Current	1.5 mA	1.36 mA	1 mA	1.02 mA	1.04 mA	1.1 mA	0.17 mA
<b>Front panel display accuracy (4 digits +/-1 count)</b>							
Voltage	50 mV	75 mV	100 mV	150 mV	200 mV	250 mV	300 mV
Current	100 mA	68 mA	50 mA	34 mA	26 mA	20 mA	17 mA
<b>Temperature stability<sup>3</sup></b>							
Voltage	10 mV	15 mV	20 mV	30 mV	40 mV	50 mV	60 mV
Current	5 mA	3.4 mA	2.5 mA	1.7 mA	1.3 mA	1 mA	0.85 mA
<b>Temperature Coefficient (ppm/C)<sup>4</sup></b>							
Voltage	50	50	50	50	50	50	50
Current	100	70	70	70	70	70	70
<b>Warm-up drift<sup>5</sup></b>							
Voltage	52 mV	77 mV	102 mV	152 mV	202 mV	252 mV	302 mV
Current	125 mA	51 mA	37.5 mA	25.5 mA	19.5 mA	15 mA	12.75 mA

<sup>1</sup> The maximum voltage on the power supply terminals must not exceed the rated voltage.

<sup>2</sup> From 5 Hz to 1 MHz for rms noise.

<sup>3</sup> Temperature stability applies over 8hrs interval following 30 minutes warm-up. Constant line, load & temperature.

<sup>4</sup> Temperature coefficient applies following 30 minute warm up period.

<sup>5</sup> Warm up drift occurs during 30 minute period following power on as noted in footnotes 3 & 4.

## Common Characteristics

Characteristic	All Models
Command Response Time:	10 ms
Savable States:	10
Analog Programming	
Input range:	0 to 5 V or 0 to 10 V (selectable) 0 to 5 k $\Omega$ or 0 to 10 k $\Omega$ (selectable)
Input impedance:	>10 M $\Omega$ (referenced to ground)
Output monitor range:	0 to 5 V or 0 to 10 V (selectable)
Accuracy:	
Vout voltage programming	$\pm$ 0.15% of rated Vout.
Iout voltage programming	$\pm$ 0.4% of rated Iout.
Vout resistance programming	$\pm$ 0.5% of rated Vout.
Iout resistance programming	$\pm$ 0.5% of rated Iout.
Vout monitor	$\pm$ 0.5% of rated Vout.
Iout monitor	$\pm$ 0.5% of rated Iout.
Computer Interfaces	
LXI Version:	1.5 LXI Device Specification 2016
LXI extended functions:	LXI HiSLIP, LXI VXI VXI-11 Discovery and Identification
LAN:	10/100 Base-T Ethernet (sockets, VXI-11 protocol, web user interface)
USB:	USB 2.0 (USB-TMC488 protocol)
GPIB:	IEEE 488
Language:	SCPI-1999, IEEE 488.2 compliant
Regulatory Compliance:	
EMC:	Complies with European EMC Directive for test and measurement products Complies with Australian standard and carries C-Tick mark This ISM device complies with Canadian ICES-001 Cet appareil ISM est conforme à la norme NMB-001 du Canada
Safety:	Complies with European Low Voltage Directive and carries the CE-marking. Conforms to US and Canadian safety regulations. <b>Not applicable for IT mains supply systems</b>
Environmental	
Operating environment:	Indoor use, installation category II (for AC input), pollution degree 2
Temperature range:	0° C to 40° C*
Relative humidity:	20 to 90% (non-condensing)
Storage humidity:	10 to 90% (non-condensing)
Altitude:	Up to 3000 meters, with 2% output current derating for every 100's above 2000 m, and derating maximum ambient temperature by 1° C per every 100's above 2000 m
Non-operating Altitude:	Up to 12,000 m
Storage temperature:	-30° C to 85° C

\* For DP5761AX models (5 kW, 10 V, 500 A), temperature range is 0° C to 35° C, derate output 2.4%/° C up to 40° C

## Maximum Number of Paralleled Units by Power Level

Power Level	Max Number of Paralleled Units
3.4 kW	4
5 kW	12

## Output Terminal Isolation

No output terminal may be more than the following voltage from chassis ground:

Voltage Rating	Maximum Voltage from Ground
10 – 100 VDC	±200 VDC
150 – 600 VDC	±600 VDC
1000 VDC	±1000 VDC
1500 VDC	-1000 VDC, +1500 VDC

## Acoustic statement

Acoustic Noise Emission	1.5 kW Models	3.4 kW Models	5 kW Models
<b>At Max Fan Speed:</b>			
At Operator Position	LpA 59.2 dB	LpA 58.3 dB	LpA 58.6 dB
At Bystander Position	LpA 52.0 dB	LpA 56.8 dB	LpA 58.7 dB
<b>At Idle:</b>	LpA 47.7 dB	LpA 50.4 dB	LpA 49.0 dB

## AC Input

Models	Connections	Voltage	Frequency	Input VA	Max Input Current Per Phase
DP57xxA 1.5 kW Models	L1, L2, PE (1-phase with protective earth)	100 VAC -15% to 240 VAC +10%	50/60 Hz	1.573 kVA	10.4-19.7 A <b>(See Power Cables)</b>
DP57xxAS 3.4 kW Models	L1, L2, PE (1-phase with protective earth)	200 VAC -15% to 240 VAC +10%	50/60 Hz	3.92 kVA	22.6 A
DP57xxAL 3.4 kW, 5 kW Models	L1, L2, L3, PE (3-phase with protective earth; no neutral)	200 VAC -15% to 240 VAC +10%, line-to-line	50/60 Hz	3.95 kVA for 3.4 kW 5.85 kVA for 5.0 kW	13.1 A for 3.4 kW 19.3 A for 5.0 kW
DP57xxAH 3.4 kW, 5 kW Models	L1, L2, L3, PE (3-phase with protective earth; no neutral)	380 VAC -10% to 480 VAC +10%, line-to-line	50/60 Hz	3.95 kVA for 3.4 kW 5.85 kVA for 5.0 kW	6.5 A for 3.4 kW 9.7 A for 5.0 kW

## Dimension Diagrams

**1.5 kW Dimension diagram**

**3.4 kW Dimension diagram**

**5 kW Dimension diagram**

For 1.5 kW Units

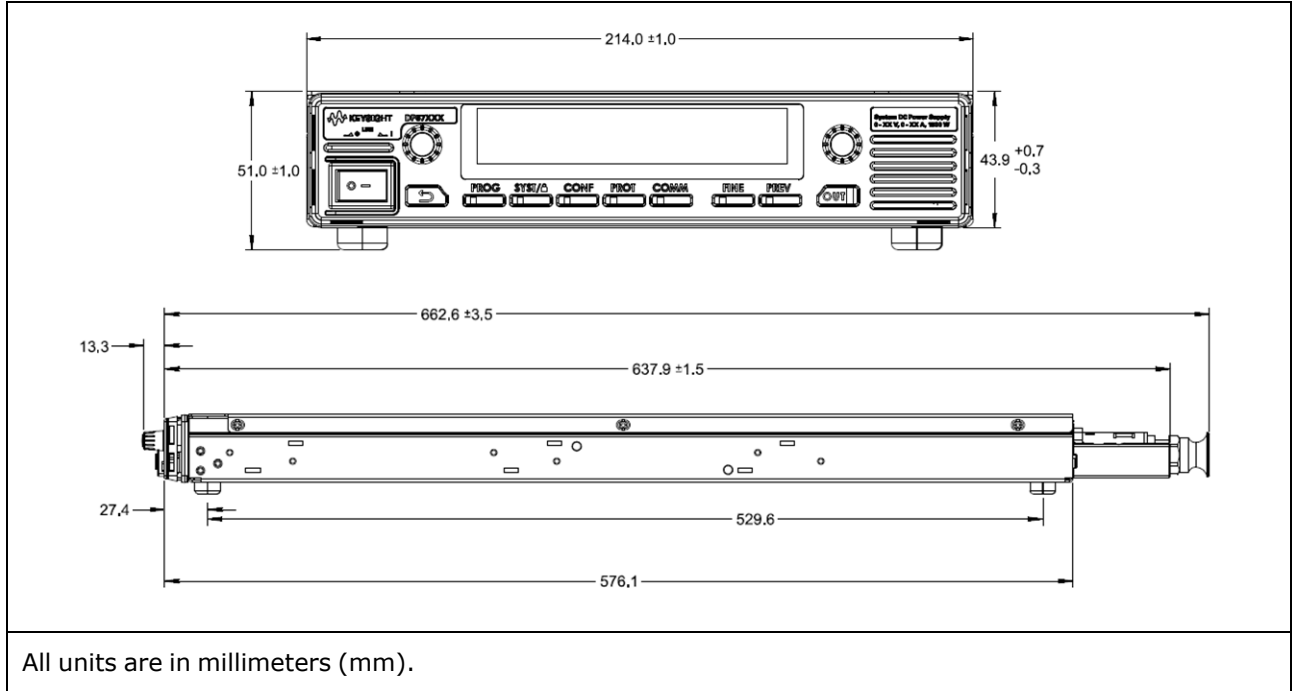

For 3.4 kW and 5 kW Units

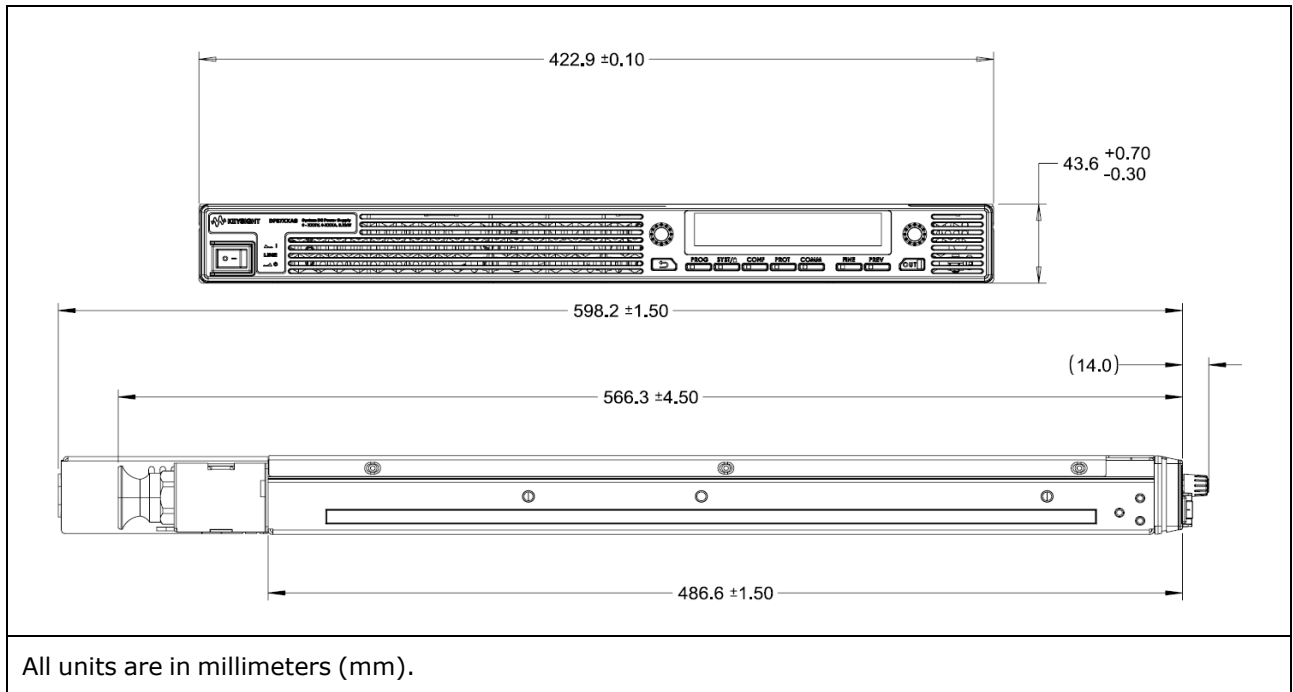



# 8

## Verification

### **Introduction**

### **Recommended Test Equipment and Setups**

### **Performance Verification**

### **Test Record Forms - 1.5 kW Models**

### **Test Record Forms - 3.4 kW Models**

### **Test Record Forms - 5.0 kW Models**

The verification procedures described in this appendix verify that the power supply is operating normally and is within published specifications.

## Introduction

### Verification

The verification procedures verify that the power supply is operating normally and is within published specifications. If the instrument fails any of the tests or if abnormal test results are obtained, return the unit to a Keysight Technologies Service Center.

**Keysight Technologies Calibration Services** – Your local Keysight Technologies Service Center offers low-cost recalibration. The service center uses automated calibration systems that allow Keysight to provide calibration at competitive prices.

Keysight Technologies recommends that complete verification should always be performed at the calibration interval. If the power supply passes the verification tests, the unit is operating within its calibration limits and does not need to be re-calibrated. This ensures that the instrument will remain within specifications for the next calibration interval and provides the best long-term stability. Performance data measured using this method can be used to extend future calibration intervals.

### Calibration Interval

The instrument should be calibrated on a regular interval determined by the accuracy requirements of your application. A 1-year interval is adequate for most applications. Accuracy specifications are warranted only if adjustment is made at regular calibration intervals. Accuracy specifications are not warranted beyond the 1-year calibration interval.

### Test Considerations

For optimum performance, all verification procedures should comply with the following recommendations:

- Ambient temperature is stable, at  $23^{\circ}\text{C} \pm 5^{\circ}\text{C}$ .
- Ambient relative humidity is less than 70%.
- 30 minute warm-up period before verification or adjustment.
- Cables as short as possible, twisted or shielded to reduce noise.

### Measurement Techniques

#### Voltmeter

To ensure that the values read by the voltmeter during the verification procedure are not affected by the instantaneous measurement of the AC peaks of the output current ripple, make several DC measurements and average them. You can set up the voltmeter to do this automatically by programming  $\geq 10$  power line cycles per measurement. If you are using a Keysight 3458A DMM also turn on auto-calibration (ACAL) and the autorange function (ARANGE).

**Current Shunt**

The 4-terminal current shunt is used to make accurate current measurements. It has two monitoring terminals as well as two load terminals. Connect the voltmeter directly to the monitoring terminals. Also allow sufficient airflow for cooling.

**Electronic Load**

Many of the test procedures require the use of a variable load capable of dissipating the required power. For most tests, an electronic load can be used. The electronic load is considerably easier to use than load resistors. Note that for proper operation, the electronic load requires a minimum of 3 V to be present at its input terminals. To avoid contact with any high voltages during operation, use switches to connect and disconnect the electronic load.

When paralleling loads for higher currents during transient response testing, use the external trigger input on the loads to synchronize the transition from low current to high current operation.

Note that you may use load resistors instead of an electronic load. To avoid contact with any high voltages during operation, use switches to connect, disconnect, or short the load resistors.

**Program Control**

You may choose to automate the verification procedure. If computer controlled test setups are used, the relatively slow settling times and slew rates of the power supply must be taken into account. "Wait" statements can be used in the test program to allow for the appropriate settling times for the power supply.

## Recommended Test Equipment and Setups

### Test Equipment

### Verification Setups

### Test Equipment

The test equipment recommended for the performance verification and adjustment procedures is listed below. If the exact instrument is not available, substitute calibration standards of equivalent accuracy.

Instrument	Requirements	Recommended Model
Digital Multimeter	Resolution: 10 nV @ 1 V; Readout: 8 1/2 digits Accuracy: 20 ppm	Keysight 3458A
Current Shunt <sup>1</sup>	15 A (0.1 $\Omega$ ) 50 A (0.05 $\Omega$ ) 300 A (0.001 $\Omega$ ) 1000 A (0.0001 $\Omega$ )	Guildline 9230-15R Guildline 9230-50, OPT 92310 Guildline 9230-300, OPT 92310 Guildline 9230A/1000, OPT 92310
Electronic load <sup>1</sup>	20 V, 800 A 80 V, 250 A 160 V, 125 A 500 V, 120 A 1000 V, 60 A 2000 V, 30 A	RP7933A / RP7943A RP7935A / RP7945A RP7936A / RP7946A RP7971A RP7972A RP7973A
GPIB controller	Full GPIB capabilities	Keysight 82350B or equivalent
Oscilloscope	Sensitivity: 1 mV Bandwidth Limit: 20 MHz	Keysight DSO6054A or equivalent
RMS Voltmeter	True RMS Bandwidth: 300 kHz	Keysight 34410A or equivalent
Voltage divider	5 kV to 5 V (1000 to 1) Accuracy: 0.025%	Ohms-Lab KVVB-5-5 or equivalent
Differential Amplifier	Bandwidth: 20 MHz	LeCroy DA1855A, DA1850A, or equivalent
Differential Probe	100:1 / 10:1 selectable	LeCroy DXC100A or equivalent
Terminations	1 – 50 $\Omega$ BNC termination	

<sup>1</sup> Dependent on rating of model being tested

## Verification Setups

### WARNING

Many models generate voltages above 60 VDC, with some models rated at up to 1,500 VDC! Ensure that all instrument connections, load wiring, and load connections are insulated or covered so that no accidental contact with lethal voltages can occur.

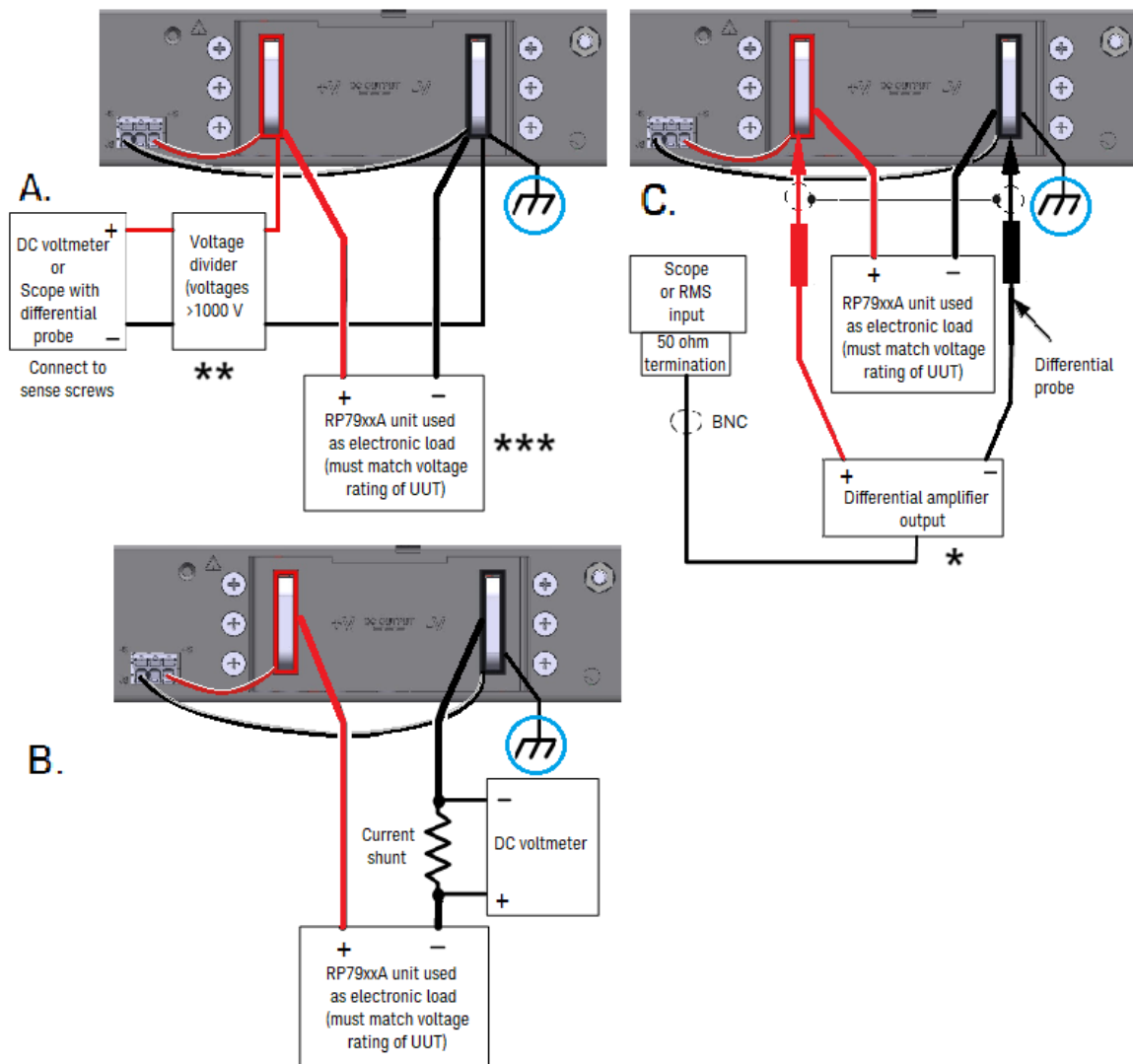

\* **CAUTION** The DA1855A or equivalent amplifier probe is limited to 500 V. Only connect for CV Ripple and Noise tests for test points of 500 V and below!

\*\* **CAUTION** Use voltage divider for models rated above 1000 V in **Test Setup A**

\*\*\* Use for Constant Voltage Load Effect test only.

## Performance Verification

### Voltage Programming and Readback Accuracy

#### Constant Voltage Load Effect

#### Constant Voltage Source Effect

#### Constant Voltage Ripple and Noise

#### Transient Recovery Time

### Current Programming and Readback Accuracy

#### Constant Current Load Effect

#### Constant Current Source Effect

#### WARNING

**HAZARDOUS VOLTAGES** The output may be enabled at turn-on, depending on the **\*PON setting**. Check this setting before attaching anything to the output terminals.

Use voltage divider for models rated above 1000 V in **Test Setup A**

---

The following types of performance verification tests are available:

- **Self-Test** A self-test occurs whenever you turn on the instrument. This limited test assures that the instrument is operational. If a self-test error occurs, do not perform the verification tests. For details, see Self-Test Procedures.
- **Performance Verification Tests** Performance verification tests verify that the power supply is operating normally and meets its published specifications.

The performance verification tests are recommended as acceptance tests when you first receive the instrument. The acceptance test results should be compared against the instrument specifications. After acceptance, you should repeat the performance verification tests after every calibration interval.

Perform the verification tests before calibrating your power supply. If the power supply passes the verification tests, the unit is operating within its calibration limits and does not need to be re-calibrated.

If the instrument fails any of the tests or if abnormal test results are obtained, return the unit to a Keysight Technologies Service Center for calibration.

Refer to **Recommended Test Equipment and Setups** for the equipment list and test setups required for verification. Refer to the Measurement Techniques section for information about setting up the voltmeter, connecting the current shunt, and connecting the electronic load.

**WARNING**

Many models generate voltages above 60 VDC, with some models rated at up to 1,500 VDC! Ensure that all instrument connections, load wiring, and load connections are insulated or covered so that no accidental contact with lethal voltages can occur.

Always turn off the output when connecting or disconnecting any equipment on the sense or output terminals of the unit.

---

**CAUTION**

**Equipment Damage** It is recommended to set the overvoltage protection function of the instrument slightly higher than its operating point during the verification procedure. This will prevent damage to any external equipment (electronic load, differential amplifier) that may occur if the output voltage is accidentally programmed higher than the prescribed voltage setting.

---

**NOTE**

Turn the unit off or send a Reset command after completing the verification procedure to return all instrument settings to their default values.

---

## Voltage Programming and Readback Accuracy

This test verifies that the voltage programming and measurement functions are within specifications.

**Step 1.** Turn off the power supply and connect a DMM to the output (see **Test Setup A**). Also connect the remote sense leads to the output and put the power supply in remote sensing mode (see **Output Voltage Sensing**). Do NOT connect the RP79xxA load unit.

**Step 2.** Turn on the power supply and program the instrument settings as described in the test record form under “Voltage Programming & Readback, Min Voltage”.

**Step 3.** Turn the output on. The power supply's output status should be “CV”, and the output current should be close to zero.

**Step 4.** Record the output voltage reading from the DMM and the voltage measured over the interface. The readings should be within the limits specified in the test record form for the appropriate model under “Voltage Programming & Readback, Minimum Voltage”.

**WARNING**

**SHOCK HAZARD** The next step applies the full output voltage of the power supply to the output terminals.

Before proceeding to step 5, turn off the output of the power supply and turn off the electronic load. If the electronic load is rated less than the voltage rating of the power supply, you must also physically disconnect the load from the power supply.

---

**Step 5.** Turn on the output and program the instrument settings as described in the test record form under “Voltage Programming & Readback, High Voltage”.

**Step 6.** Record the output voltage reading from the DMM and the voltage measured over the interface. The readings should be within the limits specified in the test record form for the appropriate model under “Voltage Programming & Readback, High Voltage”.

**Step 7.** Turn off the output. Disconnect the **remote sense** leads from the output, put the power supply in **local sensing** mode (see **Output Voltage Sensing**), and **repeat steps 1 through 6**. This verifies the voltage programming and readback accuracy with local sensing. In local sense mode the sense terminals are internally connected to the output terminals.

### Constant Voltage Load Effect

This test measures the change in output voltage resulting from a large change in output current.

**Step 1.** Keep the connections as in Voltage Programming and Readback Accuracy (see **Test Setup A**). Connect the remote sense leads and put the power supply in remote sensing mode (see **Output Voltage Sensing**).

**Step 2.** Turn on the power supply and program the instrument settings as described in the test record form under “CV Load Effect”.

**Step 3.** Set the electronic load to the first current value as described in the test record form under “CV Load Effect”. The power supply's output status should be “CV”.

**Step 4.** Record the output voltage reading from the DMM.

**Step 5.** Set the electronic load to the second current value as described in the test record form under “CV Load Effect”. Record the voltage reading from the DMM again. The difference between the DMM readings in steps 4 and 5 is the load effect, which should not exceed the value listed in the test record form for the appropriate model under “CV Load Effect”.

### Constant Voltage Source Effect

This test measures the change in output voltage that results from a change in AC line voltage from the minimum to maximum value within the line voltage specifications.

**Step 1.** Turn off the power supply and connect the ac power line through a variable voltage transformer.

**Step 2.** Connect a DVM and an electronic load as shown in **Test Setup A**. Set the variable voltage transformer to nominal line voltage.

**Step 3.** Turn on the power supply and program the output current to its maximum programmable value ( $I_{max}$ ) and the output voltage to its full-scale value.

**Step 4.** Set the electronic load for the output's full-scale current. The CV annunciator on the front panel must be on. If it is not, adjust the load so that the output current drops slightly.

**Step 5.** Adjust the transformer to the low line voltage (85 VAC for 100–240 nominal line; 170 VAC for 200–240 nominal line; 323 VAC for 380–480 nominal line).

**Step 6.** Record the output voltage reading from the DVM.

**Step 7.** Adjust the transformer to the high line voltage (264 VAC for 100–240 nominal line; 264 VAC for 200–240 nominal line; 528 VAC for 380–480 nominal line).

**Step 8.** Record the output voltage reading on the DVM. The difference between the DVM reading in steps 6 and 8 is the source effect, which should not exceed the value listed in the test record for the appropriate model under CV Source Effect.

### Constant Voltage Ripple and Noise

Periodic and random deviations in the output combine to produce a residual AC voltage superimposed on the DC. This residual voltage is specified as the rms or peak-to-peak noise in the indicated frequency range (see [Specifications](#)).

**Step 1.** Turn off the power supply and connect an electronic load, differential amplifier, and an oscilloscope (ac coupled) to the output (see [Test Setup C](#)).

**Step 2.** As shown in the diagram, use the differential probe to connect the differential amplifier to the + and - output terminals. The shields of the two probes should be connected together. Connect the output of the differential amplifier to the oscilloscope with a 50  $\Omega$  termination at the input of the oscilloscope.

**Step 3.** Set the inputs of the differential amplifier to match the probes. Set the inputs to AC coupling. Set the input resistance to 1 M $\Omega$ . Set the oscilloscope's time base to 10 ms/div, and the vertical scale to the maximum sensitivity without clipping the waveform. Turn the bandwidth limit on (20 or 30 MHz), and set the sampling mode to peak detect.

**Step 4.** Program the power supply to the settings indicated in the test record form for the appropriate model under "CV Ripple and Noise" and enable the output. Let the oscilloscope run for a few seconds to generate enough measurement points. The result should not exceed the peak-to-peak limits in the test record form for the appropriate model under "CV Ripple and Noise, peak-to-peak".

**NOTE**

If the measurement contains any question marks, clear the measurement and try again. This means that some of the scope data received was questionable.

---

**Step 5.** Disconnect the oscilloscope and connect an rms voltmeter in its place. Do not disconnect the 50 ohm termination. Divide the reading of the rms voltmeter according to the differential amplifier setting. The result should not exceed the rms limits in the test record form for the appropriate model under "CV Ripple and Noise, rms".

## Transient Recovery Time

This test measures the time for the output voltage to recover to within the specified value following a 10% to 90% change in the load current.

**Step 1.** Turn off the unit under test. Connect an oscilloscope with the specified probe across the sense terminals (see **Test Setup A**). Connect the RP79xxA load unit to the output terminals.

**Step 2.** Turn on the unit under test and program the instrument settings as described in the test record form under “Transient Response”.

**Step 3.** Set the RP79xxA load's list generator to generate a 100 Hz current waveform with a duty cycle of 50%. If using 2 - RP797xA units as a load, set one unit in CC to pull a constant current, and use the second unit to create the current step. Use the following commands to program the list:

FUNC:CURR - specifies current priority

VOLT:LIM MAX - specifies the voltage limit

DIAG:OF:CURR:BWID:LEV 3 - specifies bandwidth level 3, which generates a 40  $\mu$ s risetime step in the load list

CURR:MODE LIST - specifies current priority

LIST:CURR <low\_value>, <high\_value> - refer to test record card for low and high current values

LIST:DWEL 0.005, 0.005 - specifies a 100 Hz current waveform with a 50% duty cycle

LIST:COUN INF - sets the list count to infinity

INIT:TRAN - initiates the transient system

TRIG:TRAN - triggers the transient system

OUTP:ON - turns on the load

**Step 4.** Adjust the oscilloscope for a waveform similar to that shown in the following figure.

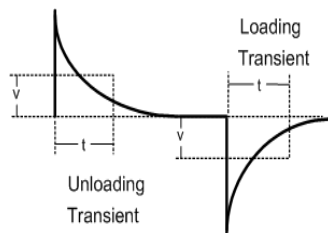

**Step 5.** The output voltage should return to within the specified voltage at the specified time after the load change. Check both loading and unloading transients by triggering on the positive and negative slope. Record the voltage at time “t” in the performance test record form under “Transient Response”.

## Current Programming and Readback Accuracy

This test verifies that the current programming and measurement functions are within specifications.

**Step 1.** Turn off the power supply and connect an electronic load and a precision current shunt to the output terminals. The current shunt should be able to measure the power supply's rated current. Connect a DMM directly across the current shunt (see **Test Setup B**).

**Step 2.** Turn on the power supply and program the instrument settings as described in the test record form under “Current Programming & Readback, Min Current”. Turn the output on.

**Step 3.** Turn on the electronic load and set it to CV mode. Program it to the voltage setting described in the test record under “Current Programming & Readback, Min Current”. The power supply's output status should be “CC”, and the output voltage should be close to the electronic load's voltage setting.

**Step 4.** Divide the voltage drop (DMM reading) across the current shunt by the shunt resistance to convert to amps and record this value. Also, record the current measured over the interface. The readings should be within the limits specified in the test record form for the appropriate model under “Current Programming & Readback, Minimum Current”.

**Step 5.** Program the instrument settings as described in the test record form under “Current Programming & Readback, High Current”.

**Step 6.** Divide the voltage drop (DMM reading) across the current shunt by the shunt resistance to convert to amps and record this value. Also, record the current reading measured over the interface. The readings should be within the limits specified in the test record form for the appropriate model under “Current Programming & Readback, High Current”.

### Constant Current Load Effect

This test measures the change in output current following a large change in output voltage.

**Step 1.** Keep the connections as in Current Programming and Readback Accuracy (see [Test Setup B](#)).

**Step 2.** Turn on the power supply and program the instrument settings as described in the test record under “CC Load Effect”.

**Step 3.** Set the electronic load to the first voltage value as described in the test record form under “CC Load Effect”. The power supply's output status should be “CC”.

**Step 4.** Divide the voltage drop (DMM reading) across the current shunt by the shunt resistance to convert to amps and record this value.

**Step 5.** Set the electronic load to the second voltage value as described in the test record form under “CC Load Effect”. Divide the voltage drop (DMM reading) across the current shunt by the shunt resistance to convert to amps and record this value. The difference in the current readings in steps 4 and 5 is the load effect, which should not exceed the value listed in the test record for the appropriate model under “CC Load Effect”.

### Constant Current Source Effect

This test measures the change in output current that results from a change in AC line voltage from the minimum to maximum value within the line voltage specifications.

**Step 1.** Turn off the power supply and connect the ac power line through a variable voltage transformer or AC source.

**Step 2.** Connect the current shunt, DVM, and electronic load as shown in [Test Setup B](#). Connect the DVM directly across the current shunt. Set the variable voltage transformer to nominal line voltage.

## 8 Verification

**Step 3.** To ensure that the values read during this test are not the instantaneous measurement of the AC peaks of the output current ripple, several DC measurements should be made and averaged. If you are using a Keysight 3458A, you can set up the voltmeter to do this automatically. From the instrument's front panel, program 100 power line cycles per measurement. Press NPLC 100 ENTER.

**Step 4.** Turn on the power supply and program the output current to its full-scale value and the output voltage to its maximum programmable value ( $V_{max}$ ).

**Step 5.** With the electronic load in CV mode, set it for the output's full-scale voltage. The CC annunciator on the front panel must be on. If it is not, adjust the load so that the voltage drops slightly.

**Step 6.** Adjust the transformer to the low line voltage (85 VAC for 100-240 nominal line; 170 VAC for 200-240 nominal line; 323 VAC for 380-480 nominal line).

**Step 7.** Divide the voltage drop (DVM reading) across the current monitoring resistor by its resistance to convert to amps and record this value ( $I_{out}$ ).

**Step 8.** Adjust the transformer to the high line voltage (264 VAC for 100-240 nominal line; 264 VAC for 200-240 nominal line; 528 VAC for 380-480 nominal line).

**Step 9.** Divide the voltage drop (DVM reading) across the current shunt by its resistance to convert to amps and record this value ( $I_{out}$ ). The difference between the DVM reading in steps 6 and 8 is the source effect, which should not exceed the value listed in the test record for the appropriate model under CC Source Effect.

**Step 10.** Return the voltage and current settings to zero.

## Test Record Forms – 1.5 kW Models

## Keysight DP5721A

DP5721A Test Record	Report Number _____	Date _____	
Test Description	Min. Specs	Results	Max. Specs
Voltage Programming & Readback (in Remote Sense)			
Minimum voltage (Vout):	- 0.005 V	_____	0.005 V
Voltage measured over interface:	Vdmm – 0.005 V	_____	Vdmm + 0.005 V
High voltage (Vout):	9.995 V	_____	10.005 V
Voltage measured over interface:	Vdmm – 0.005 V	_____	Vdmm + 0.005 V
Voltage Programming & Readback (in Local Sense)			
Minimum voltage (Vout):	- 0.005 V	_____	0.005 V
Voltage measured over interface:	Vdmm – 0.005 V	_____	Vdmm + 0.005 V
High voltage (Vout):	9.995 V	_____	10.005 V
Voltage measured over interface:	Vdmm – 0.005 V	_____	Vdmm + 0.005 V
CV Source Effect	- 0.001 V	_____	+ 0.001 V
CV Load Effect:	- 0.003 V	_____	+ 0.003 V
CV Ripple and Noise			
peak-to-peak:	N/A	_____	+ 50 mV
rms:		_____	+ 6 mV
Transient response: @ 1 ms	- 0.1 V	_____	+ 0.1 V
Current Programming & Readback			
Minimum current (Iout):	- 0.3 A	_____	0.3 A
Current measured over interface:	Idmm – 0.3 A	_____	Idmm + 0.3 A
High current (Iout):	149.55 A	_____	150.45 A
Current measured over interface:	Idmm – 0.3 A	_____	Idmm + 0.3 A
CC Source Effect	- 0.017 A	_____	+ 0.017 A
CC Load Effect:	- 0.035 A	_____	+ 0.035 A

Test Description	Instrument Setting	Electronic Load Setting
Voltage Programming & Readback Min Voltage:	0 V, 1 A	N/A
Voltage Programming & Readback High Voltage:	10 V, 1 A	N/A
CV Load Effect, CV Source Effect:	10 V, 153 A	10.2 V, -150 A
CV Ripple and Noise:	10 V, 153 A	10.2 V, -150 A
Transient Response:	10 V, 153 A	10.2 V from -15 A to -135 A
Current Programming & Readback Min Current:	10.2 V, 0 A	N/A
Current Programming & Readback High Current:	10.2 V, 150 A	N/A
CC Load Effect, CC Source Effect:	10.2 V, 150 A	10 V, -153 A

## Keysight DP5722A

DP5722A Test Record	Report Number _____	Date _____	
Test Description	Min. Specs	Results	Max. Specs
Voltage Programming & Readback (in Remote Sense)			
Minimum voltage (Vout):	- 0.01 V	_____	0.01 V
Voltage measured over interface:	Vdmm - 0.01 V	_____	Vdmm + 0.01 V
High voltage (Vout):	19.99 V	_____	20.01 V
Voltage measured over interface:	Vdmm - 0.01 V	_____	Vdmm + 0.01 V
Voltage Programming & Readback (in Local Sense)			
Minimum voltage (Vout):	- 0.01 V	_____	0.01 V
Voltage measured over interface:	Vdmm - 0.01 V	_____	Vdmm + 0.01 V
High voltage (Vout):	19.99 V	_____	20.01 V
Voltage measured over interface:	Vdmm - 0.01 V	_____	Vdmm + 0.01 V
CV Source Effect	- 0.002 V	_____	+ 0.002 V
CV Load Effect:	- 0.004 V	_____	+ 0.004 V
CV Ripple and Noise			
peak-to-peak:	N/A	_____	+ 50 mV
rms:		_____	+ 6 mV
Transient response: @ 1 ms	- 0.2 V	_____	+ 0.2 V
Current Programming & Readback			
Minimum current (Iout):	- 0.15 A	_____	0.15 A
Current measured over interface:	Idmm - 0.15 A	_____	Idmm + 0.15 A
High current (Iout):	74.775 A	_____	75.225 A
Current measured over interface:	Idmm - 0.15 A	_____	Idmm + 0.15 A
CC Source Effect	- 0.0095 A	_____	+ 0.0095 A
CC Load Effect:	- 0.02 A	_____	+ 0.02 A

Test Description	Instrument Setting	Electronic Load Setting
Voltage Programming & Readback Min Voltage:	0 V, 1 A	N/A
Voltage Programming & Readback High Voltage:	20 V, 1 A	N/A
CV Load Effect, CV Source Effect:	20 V, 76.5 A	20.4 V, -75 A
CV Ripple and Noise:	20 V, 76.5 A	20.4 V, -75 A
Transient Response:	20 V, 76.5 A	20.4 V from -7.5 A to -67.5 A
Current Programming & Readback Min Current:	20.4 V, 0 A	N/A
Current Programming & Readback High Current:	20.4 V, 75 A	N/A
CC Load Effect, CC Source Effect:	20.4 V, 75 A	20 V, -76.5 A

## Keysight DP5723A

DP5723A Test Record	Report Number _____	Date _____	
Test Description	Min. Specs	Results	Max. Specs
Voltage Programming & Readback (in Remote Sense)			
Minimum voltage (Vout):	- 0.015 V	_____	0.015 V
Voltage measured over interface:	Vdmm - 0.015 V	_____	Vdmm +0.015 V
High voltage (Vout):	29.985 V	_____	30.015 V
Voltage measured over interface:	Vdmm - 0.015 V	_____	Vdmm + 0.015 V
Voltage Programming & Readback (in Local Sense)			
Minimum voltage (Vout):	- 0.015 V	_____	0.015 V
Voltage measured over interface:	Vdmm - 0.015 V	_____	Vdmm +0.015 V
High voltage (Vout):	29.985 V	_____	30.015 V
Voltage measured over interface:	Vdmm - 0.015 V	_____	Vdmm + 0.015 V
CV Source Effect	- 0.003 V	_____	+ 0.003 V
CV Load Effect:	- 0.005 V	_____	+ 0.005 V
CV Ripple and Noise			
peak-to-peak:	N/A	_____	+ 50 mV
rms:		_____	+ 6 mV
Transient response: @ 1 ms	- 0.3 V	_____	+ 0.3 V
Current Programming & Readback			
Minimum current (Iout):	- 0.1 A	_____	0.1 A
Current measured over interface:	Idmm - 0.1 A	_____	Idmm + 0.1 A
High current (Iout):	49.85 A	_____	50.15 A
Current measured over interface:	Idmm - 0.1 A	_____	Idmm + 0.1 A
CC Source Effect	- 0.007 A	_____	+ 0.007 A
CC Load Effect:	- 0.015 A	_____	+ 0.015 A

Test Description	Instrument Setting	Electronic Load Setting
Voltage Programming & Readback Min Voltage:	0 V, 1 A	N/A
Voltage Programming & Readback High Voltage:	30 V, 1 A	N/A
CV Load Effect, CV Source Effect:	30 V, 51 A	30.6 V, -50 A
CV Ripple and Noise:	30 V, 51 A	30.6 V, -50 A
Transient Response:	30 V, 51 A	30.6 V from -5 A to -45 A
Current Programming & Readback Min Current:	30.6 V, 0 A	N/A
Current Programming & Readback High Current:	30.6 V, 50 A	N/A
CC Load Effect, CC Source Effect:	30.6 V, 50 A	30 V, -51 A

## Keysight DP5724A

DP5724A Test Record	Report Number _____	Date _____	
Test Description	Min. Specs	Results	Max. Specs
Voltage Programming & Readback (in Remote Sense)			
Minimum voltage (Vout):	- 0.02 V	_____	0.02 V
Voltage measured over interface:	Vdmm - 0.02 V	_____	Vdmm + 0.02 V
High voltage (Vout):	39.98 V	_____	40.02 V
Voltage measured over interface:	Vdmm - 0.02 V	_____	Vdmm + 0.02 V
Voltage Programming & Readback (in Local Sense)			
Minimum voltage (Vout):	- 0.02 V	_____	0.02 V
Voltage measured over interface:	Vdmm - 0.02 V	_____	Vdmm + 0.02 V
High voltage (Vout):	39.98 V	_____	40.02 V
Voltage measured over interface:	Vdmm - 0.02 V	_____	Vdmm + 0.02 V
CV Source Effect	- 0.004 V	_____	+ 0.004 V
CV Load Effect:	- 0.006 V	_____	+ 0.006 V
CV Ripple and Noise			
peak-to-peak:	N/A	_____	+ 60 mV
rms:		_____	+ 7 mV
Transient response: @ 1 ms	- 0.4 V	_____	+ 0.4 V
Current Programming & Readback			
Minimum current (Iout):	- 0.076 A	_____	0.076 A
Current measured over interface:	Idmm - 0.076 A	_____	Idmm + 0.076 A
High current (Iout):	37.886 A	_____	38.114 A
Current measured over interface:	Idmm - 0.076 A	_____	Idmm + 0.076 A
CC Source Effect	- 0.0058 A	_____	+ 0.0058 A
CC Load Effect:	- 0.0126 A	_____	+ 0.0126 A

Test Description	Instrument Setting	Electronic Load Setting
Voltage Programming & Readback Min Voltage:	0 V, 1 A	N/A
Voltage Programming & Readback High Voltage:	40 V, 1 A	N/A
CV Load Effect, CV Source Effect:	40 V, 38.76 A	40.8 V, -38 A
CV Ripple and Noise:	40 V, 38.76 A	40.8 V, -38 A
Transient Response:	40 V, 38.76 A	40.8 V from -3.8 A to -34.2 A
Current Programming & Readback Min Current:	40.8 V, 0 A	N/A
Current Programming & Readback High Current:	40.8 V, 38 A	N/A
CC Load Effect, CC Source Effect:	40.8 V, 38 A	40 V, -38.76 A

## Keysight DP5726A

DP5726A Test Record	Report Number _____	Date _____	
Test Description	Min. Specs	Results	Max. Specs
Voltage Programming & Readback (in Remote Sense)			
Minimum voltage (Vout):	- 0.03 V	_____	0.03 V
Voltage measured over interface:	Vdmm -0.03 V	_____	Vdmm + 0.03 V
High voltage (Vout):	59.97 V	_____	60.03 V
Voltage measured over interface:	Vdmm - 0.03 V	_____	Vdmm + 0.03 V
Voltage Programming & Readback (in Local Sense)			
Minimum voltage (Vout):	- 0.03 V	_____	0.03 V
Voltage measured over interface:	Vdmm -0.03 V	_____	Vdmm + 0.03 V
High voltage (Vout):	59.97 V	_____	60.03 V
Voltage measured over interface:	Vdmm - 0.03 V	_____	Vdmm + 0.03 V
CV Source Effect	- 0.006 V	_____	+ 0.006 V
CV Load Effect:	- 0.008 V	_____	+ 0.008 V
CV Ripple and Noise			
peak-to-peak:	N/A	_____	+ 60 mV
rms:		_____	+ 7 mV
Transient response: @ 1 ms	- 0.6 V	_____	+ 0.6 V
Current Programming & Readback			
Minimum current (Iout):	- 0.05 A	_____	0.05 A
Current measured over interface:	Idmm - 0.05 A	_____	Idmm + 0.05 A
High current (Iout):	24.925 A	_____	25.075 A
Current measured over interface:	Idmm - 0.05 A	_____	Idmm + 0.05 A
CC Source Effect	- 0.0045 A	_____	+ 0.0045 A
CC Load Effect:	- 0.01 A	_____	+ 0.01 A

Test Description	Instrument Setting	Electronic Load Setting
Voltage Programming & Readback Min Voltage:	0 V, 1 A	N/A
Voltage Programming & Readback High Voltage:	60 V, 1 A	N/A
CV Load Effect, CV Source Effect:	60 V, 25.5 A	61.2 V, -25 A
CV Ripple and Noise:	60 V, 25.5 A	61.2 V, -25 A
Transient Response:	60 V, 25.5 A	61.2 V from -2.5 A to -22.5 A
Current Programming & Readback Min Current:	61.2 V, 0 A	N/A
Current Programming & Readback High Current:	61.2 V, 25 A	N/A
CC Load Effect, CC Source Effect:	61.2 V, 25 A	60 V, -25.5 A

## Keysight DP5728A

DP5728A Test Record	Report Number _____	Date _____	
Test Description	Min. Specs	Results	Max. Specs
Voltage Programming & Readback (in Remote Sense)			
Minimum voltage (Vout):	- 0.04 V	_____	0.04 V
Voltage measured over interface:	Vdmm - 0.04 V	_____	Vdmm + 0.04 V
High voltage (Vout):	79.96 V	_____	80.04 V
Voltage measured over interface:	Vdmm - 0.04 V	_____	Vdmm + 0.04 V
Voltage Programming & Readback (in Local Sense)			
Minimum voltage (Vout):	- 0.04 V	_____	0.04 V
Voltage measured over interface:	Vdmm - 0.04 V	_____	Vdmm + 0.04 V
High voltage (Vout):	79.96 V	_____	80.04 V
Voltage measured over interface:	Vdmm - 0.04 V	_____	Vdmm + 0.04 V
CV Source Effect	- 0.008 V	_____	+ 0.008 V
CV Load Effect:	- 0.01 V	_____	+ 0.01 V
CV Ripple and Noise			
peak-to-peak:	N/A	_____	+ 75 mV
rms:		_____	+ 8 mV
Transient response: @ 1 ms	- 0.8 V	_____	+ 0.8 V
Current Programming & Readback			
Minimum current (Iout):	- 0.038 A	_____	0.038 A
Current measured over interface:	Idmm - 0.038 A	_____	Idmm + 0.038 A
High current (Iout):	18.943 A	_____	19.057 A
Current measured over interface:	Idmm - 0.038 A	_____	Idmm + 0.038 A
CC Source Effect	- 0.0039 A	_____	+ 0.0039 A
CC Load Effect:	- 0.0088 A	_____	+ 0.0088 A

Test Description	Instrument Setting	Electronic Load Setting
Voltage Programming & Readback Min Voltage:	0 V, 1 A	N/A
Voltage Programming & Readback High Voltage:	80 V, 1 A	N/A
CV Load Effect, CV Source Effect:	80 V, 19.38 A	81.6 V, -19 A
CV Ripple and Noise:	80 V, 19.38 A	81.6 V, -19 A
Transient Response:	80 V, 19.38 A	81.6 V from -1.9 A to -17.1 A
Current Programming & Readback Min Current:	81.6 V, 0 A	N/A
Current Programming & Readback High Current:	81.6 V, 19 A	N/A
CC Load Effect, CC Source Effect:	81.6 V, 19 A	80 V, -19.38 A

## Keysight DP5730A

DP5730A Test Record	Report Number _____	Date _____	
Test Description	Min. Specs	Results	Max. Specs
Voltage Programming & Readback (in Remote Sense)			
Minimum voltage (Vout):	- 0.05 V	_____	0.05 V
Voltage measured over interface:	Vdmm - 0.05 V	_____	Vdmm + 0.05 V
High voltage (Vout):	99.95 V	_____	100.05 V
Voltage measured over interface:	Vdmm - 0.05 V	_____	Vdmm + 0.05 V
Voltage Programming & Readback (in Local Sense)			
Minimum voltage (Vout):	- 0.05 V	_____	0.05 V
Voltage measured over interface:	Vdmm - 0.05 V	_____	Vdmm + 0.05 V
High voltage (Vout):	99.95 V	_____	100.05 V
Voltage measured over interface:	Vdmm - 0.05 V	_____	Vdmm + 0.05 V
CV Source Effect	- 0.01 V	_____	+ 0.01 V
CV Load Effect:	- 0.012 V	_____	+ 0.012 V
CV Ripple and Noise			
peak-to-peak:	N/A	_____	+ 130 mV
rms:		_____	+ 30 mV
Transient response: @ 1 ms	- 1 V	_____	+ 1 V
Current Programming & Readback			
Minimum current (Iout):	- 0.03 A	_____	0.03 A
Current measured over interface:	Idmm - 0.03 A	_____	Idmm + 0.03 A
High current (Iout):	14.955 A	_____	15.045 A
Current measured over interface:	Idmm - 0.03 A	_____	Idmm + 0.03 A
CC Source Effect	- 0.0035 A	_____	+ 0.0035 A
CC Load Effect:	- 0.008 A	_____	+ 0.008 A

Test Description	Instrument Setting	Electronic Load Setting
Voltage Programming & Readback Min Voltage:	0 V, 1 A	N/A
Voltage Programming & Readback High Voltage:	100 V, 1 A	N/A
CV Load Effect, CV Source Effect:	100 V, 15.3 A	102 V, -15 A
CV Ripple and Noise:	100 V, 15.3 A	102 V, -15 A
Transient Response:	100 V, 15.3 A	102 V from -1.5 A to -13.5 A
Current Programming & Readback Min Current:	102 V, 0 A	N/A
Current Programming & Readback High Current:	102 V, 15 A	N/A
CC Load Effect, CC Source Effect:	102 V, 15 A	100 V, -15.3 A

## Keysight DP5731A

DP5731A Test Record	Report Number _____	Date _____	
Test Description	Min. Specs	Results	Max. Specs
Voltage Programming & Readback (in Remote Sense)			
Minimum voltage (Vout):	- 0.075 V	_____	0.075 V
Voltage measured over interface:	Vdmm - 0.075 V	_____	Vdmm + 0.075 V
High voltage (Vout):	149.925 V	_____	150.075 V
Voltage measured over interface:	Vdmm - 0.075 V	_____	Vdmm + 0.075 V
Voltage Programming & Readback (in Local Sense)			
Minimum voltage (Vout):	- 0.075 V	_____	0.075 V
Voltage measured over interface:	Vdmm - 0.075 V	_____	Vdmm + 0.075 V
High voltage (Vout):	149.925 V	_____	150.075 V
Voltage measured over interface:	Vdmm - 0.075 V	_____	Vdmm + 0.075 V
CV Source Effect	- 0.015 V	_____	+ 0.015 V
CV Load Effect:	- 0.017 V	_____	+ 0.017 V
CV Ripple and Noise			
peak-to-peak:	N/A	_____	+ 75 mV
rms:		_____	+ 20 mV
Transient response: @ 2 ms	- 1.5 V	_____	+ 1.5 V
Current Programming & Readback			
Minimum current (Iout):	- 0.02 A	_____	0.02 A
Current measured over interface:	Idmm - 0.02 A	_____	Idmm + 0.02 A
High current (Iout):	9.97 A	_____	10.03 A
Current measured over interface:	Idmm - 0.02 A	_____	Idmm + 0.02 A
CC Source Effect	- 0.003 A	_____	+ 0.003 A
CC Load Effect:	- 0.007 A	_____	+ 0.007 A

Test Description	Instrument Setting	Electronic Load Setting
Voltage Programming & Readback Min Voltage:	0 V, 1 A	N/A
Voltage Programming & Readback High Voltage:	150 V, 1 A	N/A
CV Load Effect, CV Source Effect:	150 V, 10.2 A	153 V, -10 A
CV Ripple and Noise:	150 V, 10.2 A	153 V, -10 A
Transient Response:	150 V, 10.2 A	153 V from -1 A to -9 A
Current Programming & Readback Min Current:	153 V, 0 A	N/A
Current Programming & Readback High Current:	153 V, 10 A	N/A
CC Load Effect, CC Source Effect:	153 V, 10 A	150 V, -10.2 A

## Keysight DP5733A

DP5733A Test Record	Report Number _____	Date _____	
Test Description	Min. Specs	Results	Max. Specs
Voltage Programming & Readback (in Remote Sense)			
Minimum voltage (Vout):	- 0.15 V	_____	0.15 V
Voltage measured over interface:	Vdmm - 0.15 V	_____	Vdmm + 0.15 V
High voltage (Vout):	299.85 V	_____	300.15 V
Voltage measured over interface:	Vdmm - 0.15 V	_____	Vdmm + 0.15 V
Voltage Programming & Readback (in Local Sense)			
Minimum voltage (Vout):	- 0.15 V	_____	0.15 V
Voltage measured over interface:	Vdmm - 0.15 V	_____	Vdmm + 0.15 V
High voltage (Vout):	299.85 V	_____	300.15 V
Voltage measured over interface:	Vdmm - 0.15 V	_____	Vdmm + 0.15 V
CV Source Effect	- 0.03 V	_____	+ 0.03 V
CV Load Effect:	- 0.032 V	_____	+ 0.032 V
CV Ripple and Noise			
peak-to-peak:	N/A	_____	+ 180 mV
rms:		_____	+ 45 mV
Transient response: @ 2 ms	- 3 V	_____	+ 3 V
Current Programming & Readback			
Minimum current (Iout):	- 0.01 A	_____	0.01 A
Current measured over interface:	Idmm - 0.01 A	_____	Idmm + 0.01 A
High current (Iout):	4.985 A	_____	5.015 A
Current measured over interface:	Idmm - 0.01 A	_____	Idmm + 0.01 A
CC Source Effect	- 0.0025 A	_____	+ 0.0025 A
CC Load Effect:	- 0.006 A	_____	+ 0.006 A

Test Description	Instrument Setting	Electronic Load Setting
Voltage Programming & Readback Min Voltage:	0 V, 1 A	N/A
Voltage Programming & Readback High Voltage:	300 V, 1 A	N/A
CV Load Effect, CV Source Effect:	300 V, 5.1 A	306 V, -5 A
CV Ripple and Noise:	300 V, 5.1 A	306 V, -5 A
Transient Response:	300 V, 5.1 A	306 V from -0.5 A to -4.5 A
Current Programming & Readback Min Current:	306 V, 0 A	N/A
Current Programming & Readback High Current:	306 V, 5 A	N/A
CC Load Effect, CC Source Effect:	306 V, 5 A	300 V, -5.1 A

## Keysight DP5736A

DP5736A Test Record	Report Number _____	Date _____	
Test Description	Min. Specs	Results	Max. Specs
Voltage Programming & Readback (in Remote Sense)			
Minimum voltage (Vout):	- 0.3 V	_____	0.3 V
Voltage measured over interface:	Vdmm - 0.3 V	_____	Vdmm + 0.3 V
High voltage (Vout):	599.7 V	_____	600.3 V
Voltage measured over interface:	Vdmm - 0.3 V	_____	Vdmm + 0.3 V
Voltage Programming & Readback (in Local Sense)			
Minimum voltage (Vout):	- 0.3 V	_____	0.3 V
Voltage measured over interface:	Vdmm - 0.3 V	_____	Vdmm + 0.3 V
High voltage (Vout):	599.7 V	_____	600.3 V
Voltage measured over interface:	Vdmm - 0.3 V	_____	Vdmm + 0.3 V
CV Source Effect	- 0.06 V	_____	+ 0.06 V
CV Load Effect:	- 0.062 V	_____	+ 0.062 V
CV Ripple and Noise			
peak-to-peak:	N/A	_____	+ 500 mV
rms:		_____	+ 100 mV
Transient response: @ 2 ms	- 6 V	_____	+ 6 V
Current Programming & Readback			
Minimum current (Iout):	- 0.0052 A	_____	0.0052 A
Current measured over interface:	Idmm - 0.0052 A	_____	Idmm + 0.0052 A
High current (Iout):	2.5922 A	_____	2.6078 A
Current measured over interface:	Idmm - 0.0052 A	_____	Idmm + 0.0052 A
CC Source Effect	- 0.00226 A	_____	+ 0.00226 A
CC Load Effect:	- 0.00552 A	_____	+ 0.00552 A

Test Description	Instrument Setting	Electronic Load Setting
Voltage Programming & Readback Min Voltage:	0 V, 1 A	N/A
Voltage Programming & Readback High Voltage:	600 V, 1 A	N/A
CV Load Effect, CV Source Effect:	600 V, 2.652 A	612 V, -2.6 A
CV Ripple and Noise: *	500 V, 2.652 A	510 V, -2.6 A
Transient Response:	600 V, 2.652 A	612 V from -0.26 A to -2.34 A
Current Programming & Readback Min Current:	612 V, 0 A	N/A
Current Programming & Readback High Current:	612 V, 2.6 A	N/A
CC Load Effect, CC Source Effect:	612 V, 2.6 A	600 V, -2.652 A

\* **CAUTION** Set OVP to 110% of Instrument Voltage Rating

## Test Record Forms – 3.4 kW Models

## Keysight DP5741AS, DP5741AL &amp; DP5741AH

DP5741AS, DP5741AL & DP5741AH Test Record	Report Number _____	Date _____	
Test Description	Min. Specs	Results	Max. Specs
Voltage Programming & Readback (in Remote Sense)			
Minimum voltage (Vout):	- 0.005 V	_____	0.005 V
Voltage measured over interface:	Vdmm – 0.005 V	_____	Vdmm + 0.005 V
High voltage (Vout):	9.995 V	_____	10.005 V
Voltage measured over interface:	Vdmm – 0.005 V	_____	Vdmm + 0.005 V
Voltage Programming & Readback (in Local Sense)			
Minimum voltage (Vout):	- 0.005 V	_____	0.005 V
Voltage measured over interface:	Vdmm – 0.005 V	_____	Vdmm + 0.005 V
High voltage (Vout):	9.995 V	_____	10.005 V
Voltage measured over interface:	Vdmm – 0.005 V	_____	Vdmm + 0.005 V
CV Source Effect	- 0.001 V	_____	+ 0.001 V
CV Load Effect:	- 0.006 V	_____	+ 0.006 V
CV Ripple and Noise			
peak-to-peak:	N/A	_____	+ 75 mV
rms:		_____	+ 8 mV
Transient response: @ 1 ms	- 0.05 V	_____	+ 0.05 V
Current Programming & Readback			
Minimum current (Iout):	- 0.68 A	_____	0.68 A
Current measured over interface:	Idmm – 0.68 A	_____	Idmm + 0.68 A
High current (Iout):	338.98 A	_____	341.02 A
Current measured over interface:	Idmm – 0.68 A	_____	Idmm + 0.68 A
CC Source Effect	- 0.17 A	_____	+ 0.17 A
CC Load Effect:	- 0.272 A	_____	+ 0.272 A

Test Description	Instrument Setting	Electronic Load Setting
Voltage Programming & Readback Min Voltage:	0 V, 1 A	N/A
Voltage Programming & Readback High Voltage:	10 V, 1 A	N/A
CV Load Effect, CV Source Effect:	10 V, 346.8 A	10.2 V, -340 A
CV Ripple and Noise:	10 V, 346.8 A	10.2 V, -340 A
Transient Response:	10 V, 346.8 A	10.2 V from -340 A to -346.8 A
Current Programming & Readback Min Current:	10.2 V, 0 A	N/A
Current Programming & Readback High Current:	10.2 V, 340 A	N/A
CC Load Effect, CC Source Effect:	10.2 V, 340 A	10 V, -346.8 A

## Keysight DP5742AS, DP5742AL & DP5742AH

DP5742AS, DP5742AL & DP5742AH Test Record		Report Number _____	Date _____
Test Description	Min. Specs	Results	Max. Specs
Voltage Programming & Readback (in Remote Sense)			
Minimum voltage (Vout):	- 0.01 V	_____	0.01 V
Voltage measured over interface:	Vdmm - 0.01 V	_____	Vdmm + 0.01 V
High voltage (Vout):	19.99 V	_____	20.01 V
Voltage measured over interface:	Vdmm - 0.01 V	_____	Vdmm + 0.01 V
Voltage Programming & Readback (in Local Sense)			
Minimum voltage (Vout):	- 0.01 V	_____	0.01 V
Voltage measured over interface:	Vdmm - 0.01 V	_____	Vdmm + 0.01 V
High voltage (Vout):	19.99 V	_____	20.01 V
Voltage measured over interface:	Vdmm - 0.01 V	_____	Vdmm + 0.01 V
CV Source Effect	- 0.002 V	_____	+ 0.002 V
CV Load Effect:	- 0.007 V	_____	+ 0.007 V
CV Ripple and Noise			
peak-to-peak:	N/A	_____	+ 75 mV
rms:		_____	+10 mV
Transient response: @ 1 ms	- 0.1 V	_____	+ 0.1 V
Current Programming & Readback			
Minimum current (Iout):	- 0.34 A	_____	0.34 A
Current measured over interface:	Idmm - 0.34 A	_____	Idmm + 0.34 A
High current (Iout):	169.49 A	_____	170.51 A
Current measured over interface:	Idmm - 0.34 A	_____	Idmm + 0.34 A
CC Source Effect	- 0.085 A	_____	+ 0.085 A
CC Load Effect:	- 0.136 A	_____	+ 0.136 A

Test Description	Instrument Setting	Electronic Load Setting
Voltage Programming & Readback Min Voltage:	0 V, 1 A	N/A
Voltage Programming & Readback High Voltage:	20 V, 1 A	N/A
CV Load Effect, CV Source Effect:	20 V, 173.4 A	20.4 V, -170 A
CV Ripple and Noise:	20 V, 173.4 A	20.4 V, -170 A
Transient Response:	20 V, 173.4 A	20.4 V from -17 A to -153 A
Current Programming & Readback Min Current:	20.4 V, 0 A	N/A
Current Programming & Readback High Current:	20.4 V, 170 A	N/A
CC Load Effect, CC Source Effect:	20.4 V, 170 A	20 V, -173.4 A

## Keysight DP5743AS, DP5743AL & DP5743AH

DP5743AS, DP5743AL & DP5743AH Test Record		Report Number _____	Date _____
Test Description	Min. Specs	Results	Max. Specs
Voltage Programming & Readback (in Remote Sense)			
Minimum voltage (Vout):	- 0.015 V	_____	0.015 V
Voltage measured over interface:	Vdmm - 0.015 V	_____	Vdmm +0.015 V
High voltage (Vout):	29.985 V	_____	30.015 V
Voltage measured over interface:	Vdmm - 0.015 V	_____	Vdmm + 0.015 V
Voltage Programming & Readback (in Local Sense)			
Minimum voltage (Vout):	- 0.015 V	_____	0.015 V
Voltage measured over interface:	Vdmm - 0.015 V	_____	Vdmm +0.015 V
High voltage (Vout):	29.985 V	_____	30.015 V
Voltage measured over interface:	Vdmm - 0.015 V	_____	Vdmm + 0.015 V
CV Source Effect	- 0.003 V	_____	+ 0.003 V
CV Load Effect:	- 0.008 V	_____	+ 0.008 V
CV Ripple and Noise			
peak-to-peak:	N/A	_____	+ 75 mV
rms:		_____	+ 10 mV
Transient response: @ 1 ms	- 0.15 V	_____	+ 0.15 V
Current Programming & Readback			
Minimum current (Iout):	- 0.224 A	_____	0.224 A
Current measured over interface:	Idmm - 0.224 A	_____	Idmm + 0.224 A
High current (Iout):	111.664 A	_____	112.336A
Current measured over interface:	Idmm - 0.224 A	_____	Idmm + 0.224 A
CC Source Effect	- 0.056 A	_____	+ 0.056 A
CC Load Effect:	- 0.0896 A	_____	+ 0.0896 A

Test Description	Instrument Setting	Electronic Load Setting
Voltage Programming & Readback Min Voltage:	0 V, 1 A	N/A
Voltage Programming & Readback High Voltage:	30 V, 1 A	N/A
CV Load Effect, CV Source Effect:	30 V, 114.24 A	30.6 V, -112 A
CV Ripple and Noise:	30 V, 114.24 A	30.6 V, -112 A
Transient Response:	30 V, 114.24 A	30.6 V from -11.2 A to -100.8 A
Current Programming & Readback Min Current:	30.6 V, 0 A	N/A
Current Programming & Readback High Current:	30.6 V, 112 A	N/A
CC Load Effect, CC Source Effect:	30.6 V, 112 A	30 V, -114.24 A

## Keysight DP5744AS, DP5744AL & DP5744AH

DP5744AS, DP5744AL & DP5744AH Test Record		Report Number _____	Date _____
Test Description	Min. Specs	Results	Max. Specs
Voltage Programming & Readback (in Remote Sense)			
Minimum voltage (Vout):	- 0.02 V	_____	0.02 V
Voltage measured over interface:	Vdmm - 0.02 V	_____	Vdmm + 0.02 V
High voltage (Vout):	39.98 V	_____	40.02 V
Voltage measured over interface:	Vdmm - 0.02 V	_____	Vdmm + 0.02 V
Voltage Programming & Readback (in Local Sense)			
Minimum voltage (Vout):	- 0.02 V	_____	0.02 V
Voltage measured over interface:	Vdmm - 0.02 V	_____	Vdmm + 0.02 V
High voltage (Vout):	39.98 V	_____	40.02 V
Voltage measured over interface:	Vdmm - 0.02 V	_____	Vdmm + 0.02 V
CV Source Effect	- 0.004 V	_____	+ 0.004 V
CV Load Effect:	- 0.009 V	_____	+ 0.009 V
CV Ripple and Noise			
peak-to-peak:	N/A	_____	+ 75 mV
rms:		_____	+ 12 mV
Transient response: @ 1 ms	- 0.2 V	_____	+ 0.2 V
Current Programming & Readback			
Minimum current (Iout):	- 0.17 A	_____	0.17 A
Current measured over interface:	Idmm - 0.17 A	_____	Idmm + 0.17 A
High current (Iout):	84.745 A	_____	85.255 A
Current measured over interface:	Idmm - 0.17 A	_____	Idmm + 0.17 A
CC Source Effect	- 0.0425 A	_____	+ 0.0425 A
CC Load Effect:	- 0.068 A	_____	+ 0.068 A

Test Description	Instrument Setting	Electronic Load Setting
Voltage Programming & Readback Min Voltage:	0 V, 1 A	N/A
Voltage Programming & Readback High Voltage:	40 V, 1 A	N/A
CV Load Effect, CV Source Effect:	40 V, 86.7 A	40.8 V, -85 A
CV Ripple and Noise:	40 V, 86.7 A	40.8 V, -85 A
Transient Response:	40 V, 86.7 A	40.8 V from -8.5 A to -76.5 A
Current Programming & Readback Min Current:	40.8 V, 0 A	N/A
Current Programming & Readback High Current:	40.8 V, 85 A	N/A
CC Load Effect, CC Source Effect:	40.8 V, 85 A	40 V, -86.7 A

## Keysight DP5746AS, DP5746AL &amp; DP5746AH

DP5746AS, DP5746AL & DP5746AH Test Record		Report Number _____	Date _____
Test Description	Min. Specs	Results	Max. Specs
Voltage Programming & Readback (in Remote Sense)			
Minimum voltage (Vout):	- 0.03 V	_____	0.03 V
Voltage measured over interface:	Vdmm -0.03 V	_____	Vdmm + 0.03 V
High voltage (Vout):	59.97 V	_____	60.03 V
Voltage measured over interface:	Vdmm - 0.03 V	_____	Vdmm + 0.03 V
Voltage Programming & Readback (in Local Sense)			
Minimum voltage (Vout):	- 0.03 V	_____	0.03 V
Voltage measured over interface:	Vdmm -0.03 V	_____	Vdmm + 0.03 V
High voltage (Vout):	59.97 V	_____	60.03 V
Voltage measured over interface:	Vdmm - 0.03 V	_____	Vdmm + 0.03 V
CV Source Effect	- 0.006 V	_____	+ 0.006 V
CV Load Effect:	- 0.011 V	_____	+ 0.011 V
CV Ripple and Noise			
peak-to-peak:	N/A	_____	+ 80 mV
rms:		_____	+ 15 mV
Transient response: @ 1 ms	- 0.3 V	_____	+ 0.3 V
Current Programming & Readback			
Minimum current (Iout):	- 0.112 A	_____	0.112 A
Current measured over interface:	Idmm - 0.112 A	_____	Idmm + 0.112 A
High current (Iout):	55.832 A	_____	56.168 A
Current measured over interface:	Idmm - 0.112 A	_____	Idmm + 0.112 A
CC Source Effect	- 0.028 A	_____	+ 0.028 A
CC Load Effect:	- 0.0448 A	_____	+ 0.0448 A

Test Description	Instrument Setting	Electronic Load Setting
Voltage Programming & Readback Min Voltage:	0 V, 1 A	N/A
Voltage Programming & Readback High Voltage:	60 V, 1 A	N/A
CV Load Effect, CV Source Effect:	60 V, 57.12 A	61.2 V, -56 A
CV Ripple and Noise:	60 V, 57.12 A	61.2 V, -56 A
Transient Response:	60 V, 57.12 A	61.2 V from -5.6 A to -50.4 A
Current Programming & Readback Min Current:	61.2 V, 0 A	N/A
Current Programming & Readback High Current:	61.2 V, 56 A	N/A
CC Load Effect, CC Source Effect:	61.2 V, 56 A	60 V, -57.12 A

## Keysight DP5748AS, DP5748AL & DP5748AH

DP5748AS, DP5748AL & DP5748AH Test Record		Report Number _____	Date _____
Test Description	Min. Specs	Results	Max. Specs
Voltage Programming & Readback (in Remote Sense)			
Minimum voltage (Vout):	- 0.04 V	_____	0.04 V
Voltage measured over interface:	Vdmm - 0.04 V	_____	Vdmm + 0.04 V
High voltage (Vout):	79.96 V	_____	80.04 V
Voltage measured over interface:	Vdmm - 0.04 V	_____	Vdmm + 0.04 V
Voltage Programming & Readback (in Local Sense)			
Minimum voltage (Vout):	- 0.04 V	_____	0.04 V
Voltage measured over interface:	Vdmm - 0.04 V	_____	Vdmm + 0.04 V
High voltage (Vout):	79.96 V	_____	80.04 V
Voltage measured over interface:	Vdmm - 0.04 V	_____	Vdmm + 0.04 V
CV Source Effect	- 0.008 V	_____	+ 0.008 V
CV Load Effect:	- 0.013 V	_____	+ 0.013 V
CV Ripple and Noise			
peak-to-peak:	N/A	_____	+ 80 mV
rms:		_____	+ 15 mV
Transient response: @ 1 ms	- 0.4 V	_____	+ 0.4 V
Current Programming & Readback			
Minimum current (Iout):	- 0.084 A	_____	0.084 A
Current measured over interface:	Idmm - 0.084 A	_____	Idmm + 0.084 A
High current (Iout):	41.874 A	_____	42.126 A
Current measured over interface:	Idmm - 0.084 A	_____	Idmm + 0.084 A
CC Source Effect	- 0.021 A	_____	+ 0.02 A
CC Load Effect:	- 0.0336 A	_____	+ 0.0336 A
Test Description	Instrument Setting	Electronic Load Setting	
Voltage Programming & Readback Min Voltage:	0 V, 1 A	N/A	
Voltage Programming & Readback High Voltage:	80 V, 1 A	N/A	
CV Load Effect, CV Source Effect:	80 V, 42.84 A	81.6 V, -42 A	
CV Ripple and Noise:	80 V, 42.84 A	81.6 V, -42 A	
Transient Response:	80 V, 42.84 A	81.6 V from -4.2 A to -37.8 A	
Current Programming & Readback Min Current:	81.6 V, 0 A	N/A	
Current Programming & Readback High Current:	81.6 V, 42 A	N/A	
CC Load Effect, CC Source Effect:	81.6 V, 42 A	80 V, -42.84 A	

## Keysight DP5750AS, DP5750AL &amp; DP5750AH

DP5750AS, DP5750AL & DP5750AH Test Record		Report Number _____	Date _____
Test Description	Min. Specs	Results	Max. Specs
Voltage Programming & Readback (in Remote Sense)			
Minimum voltage (Vout):	- 0.05 V	_____	0.05 V
Voltage measured over interface:	Vdmm - 0.05 V	_____	Vdmm + 0.05 V
High voltage (Vout):	99.95 V	_____	100.05 V
Voltage measured over interface:	Vdmm - 0.05 V	_____	Vdmm + 0.05 V
Voltage Programming & Readback (in Local Sense)			
Minimum voltage (Vout):	- 0.05 V	_____	0.05 V
Voltage measured over interface:	Vdmm - 0.05 V	_____	Vdmm + 0.05 V
High voltage (Vout):	99.95 V	_____	100.05 V
Voltage measured over interface:	Vdmm - 0.05 V	_____	Vdmm + 0.05 V
CV Source Effect	- 0.01 V	_____	+ 0.01 V
CV Load Effect:	- 0.015 V	_____	+ 0.015 V
CV Ripple and Noise			
peak-to-peak:	N/A	_____	+ 100 mV
rms:		_____	+ 15 mV
Transient response: @ 1 ms	- 0.5 V	_____	+ 0.5 V
Current Programming & Readback			
Minimum current (Iout):	- 0.068 A	_____	0.068 A
Current measured over interface:	Idmm - 0.068 A	_____	Idmm + 0.068 A
High current (Iout):	33.898 A	_____	34.102 A
Current measured over interface:	Idmm - 0.068 A	_____	Idmm + 0.068 A
CC Source Effect	- 0.017 A	_____	+ 0.017 A
CC Load Effect:	- 0.0272 A	_____	+ 0.0272 A

Test Description	Instrument Setting	Electronic Load Setting
Voltage Programming & Readback Min Voltage:	0 V, 1 A	N/A
Voltage Programming & Readback High Voltage:	100 V, 1 A	N/A
CV Load Effect, CV Source Effect:	100 V, 34.68 A	102 V, -34 A
CV Ripple and Noise:	100 V, 34.68 A	102 V, -34 A
Transient Response:	100 V, 34.68 A	102 V from -3.4 A to -30.6 A
Current Programming & Readback Min Current:	102 V, 0 A	N/A
Current Programming & Readback High Current:	102 V, 34 A	N/A
CC Load Effect, CC Source Effect:	102 V, 34 A	100 V, -34.68 A

## Keysight DP5751AS, DP5751AL & DP5751AH

DP5751AS, DP5751AL & DP5751AH Test Record		Report Number _____	Date _____
Test Description	Min. Specs	Results	Max. Specs
Voltage Programming & Readback (in Remote Sense)			
Minimum voltage (Vout):	- 0.075 V	_____	0.075 V
Voltage measured over interface:	Vdmm - 0.075 V	_____	Vdmm + 0.075 V
High voltage (Vout):	149.925 V	_____	150.075 V
Voltage measured over interface:	Vdmm - 0.075 V	_____	Vdmm + 0.075 V
Voltage Programming & Readback (in Local Sense)			
Minimum voltage (Vout):	- 0.075 V	_____	0.075 V
Voltage measured over interface:	Vdmm - 0.075 V	_____	Vdmm + 0.075 V
High voltage (Vout):	149.925 V	_____	150.075 V
Voltage measured over interface:	Vdmm - 0.075 V	_____	Vdmm + 0.075 V
CV Source Effect	- 0.015 V	_____	+ 0.015 V
CV Load Effect:	- 0.02 V	_____	+ 0.02 V
CV Ripple and Noise			
peak-to-peak:	N/A	_____	+ 120 mV
rms:		_____	+ 20 mV
Transient response: @ 2 ms	- 0.75 V	_____	+ 0.75 V
Current Programming & Readback			
Minimum current (Iout):	- 0.045 A	_____	0.045 A
Current measured over interface:	Idmm - 0.045 A	_____	Idmm + 0.045 A
High current (Iout):	22.4325 A	_____	22.5675 A
Current measured over interface:	Idmm - 0.045 A	_____	Idmm + 0.045 A
CC Source Effect	- 0.01125 A	_____	+ 0.01125 A
CC Load Effect:	- 0.018 A	_____	+ 0.018 A

Test Description	Instrument Setting	Electronic Load Setting
Voltage Programming & Readback Min Voltage:	0 V, 1 A	N/A
Voltage Programming & Readback High Voltage:	150 V, 1 A	N/A
CV Load Effect, CV Source Effect:	150 V, 22.95 A	153 V, -22.5 A
CV Ripple and Noise:	150 V, 22.95 A	153 V, -22.5 A
Transient Response:	150 V, 22.95 A	153 V from -2.25 A to -20.25 A
Current Programming & Readback Min Current:	153 V, 0 A	N/A
Current Programming & Readback High Current:	153 V, 22.5 A	N/A
CC Load Effect, CC Source Effect:	153 V, 22.5 A	150 V, -22.95 A

## Keysight DP5753AS, DP5753AL &amp; DP5753AH

DP5753AS, DP5753AL & DP5753AH Test Record		Report Number _____	Date _____
Test Description	Min. Specs	Results	Max. Specs
Voltage Programming & Readback (in Remote Sense)			
Minimum voltage (Vout):	- 0.15 V	_____	0.15 V
Voltage measured over interface:	Vdmm - 0.15 V	_____	Vdmm + 0.15 V
High voltage (Vout):	299.85 V	_____	300.15 V
Voltage measured over interface:	Vdmm - 0.15 V	_____	Vdmm + 0.15 V
Voltage Programming & Readback (in Local Sense)			
Minimum voltage (Vout):	- 0.15 V	_____	0.15 V
Voltage measured over interface:	Vdmm - 0.15 V	_____	Vdmm + 0.15 V
High voltage (Vout):	299.85 V	_____	300.15 V
Voltage measured over interface:	Vdmm - 0.15 V	_____	Vdmm + 0.15 V
CV Source Effect	- 0.03 V	_____	+ 0.03 V
CV Load Effect:	- 0.035 V	_____	+ 0.035 V
CV Ripple and Noise			
peak-to-peak:	N/A	_____	+ 200 mV
rms:		_____	+ 60 mV
Transient response: @ 2 ms	- 1.5 V	_____	+ 1.5 V
Current Programming & Readback			
Minimum current (Iout):	- 0.023 A	_____	0.023 A
Current measured over interface:	Idmm - 0.023 A	_____	Idmm + 0.023 A
High current (Iout):	11.4655 A	_____	11.5345 A
Current measured over interface:	Idmm - 0.023 A	_____	Idmm + 0.023 A
CC Source Effect	- 0.00575 A	_____	+0.00575 A
CC Load Effect:	- 0.0092 A	_____	+ 0.0092 A

Test Description	Instrument Setting	Electronic Load Setting
Voltage Programming & Readback Min Voltage:	0 V, 1 A	N/A
Voltage Programming & Readback High Voltage:	300 V, 1 A	N/A
CV Load Effect, CV Source Effect:	300 V, 11.73 A	306 V, -11.5 A
CV Ripple and Noise:	300 V, 11.73 A	306 V, -11.5 A
Transient Response:	300 V, 11.73 A	306 V from -1.15 A to -10.35 A
Current Programming & Readback Min Current:	306 V, 0 A	N/A
Current Programming & Readback High Current:	306 V, 11.5 A	N/A
CC Load Effect, CC Source Effect:	306 V, 11.5 A	300 V, -11.73 A

## Keysight DP5756AS, DP5756AL &amp; DP5756AH

DP5756AS, DP5756AL & DP5756AH Test Record		Report Number _____	Date _____
Test Description	Min. Specs	Results	Max. Specs
Voltage Programming & Readback (in Remote Sense)			
Minimum voltage (Vout):	- 0.3 V	_____	0.3 V
Voltage measured over interface:	Vdmm - 0.3 V	_____	Vdmm + 0.3 V
High voltage (Vout):	599.7 V	_____	600.3 V
Voltage measured over interface:	Vdmm - 0.3 V	_____	Vdmm + 0.3 V
Voltage Programming & Readback (in Local Sense)			
Minimum voltage (Vout):	- 0.3 V	_____	0.3 V
Voltage measured over interface:	Vdmm - 0.3 V	_____	Vdmm + 0.3 V
High voltage (Vout):	599.7 V	_____	600.3 V
Voltage measured over interface:	Vdmm - 0.3 V	_____	Vdmm + 0.3 V
CV Source Effect	- 0.06 V	_____	+ 0.06 V
CV Load Effect:	- 0.065 V	_____	+ 0.065 V
CV Ripple and Noise			
peak-to-peak:	N/A	_____	+ 480 mV
rms:		_____	+ 100 mV
Transient response: @ 2 ms	- 3 V	_____	+ 3 V
Current Programming & Readback			
Minimum current (Iout):	- 0.0112 A	_____	0.0112 A
Current measured over interface:	Idmm - 0.0112 A	_____	Idmm + 0.0112 A
High current (Iout):	5.5832 A	_____	5.6168 A
Current measured over interface:	Idmm - 0.0112 A	_____	Idmm + 0.0112 A
CC Source Effect	- 0.0028 A	_____	+ 0.0028 A
CC Load Effect:	- 0.00448 A	_____	+ 0.00448 A

Test Description	Instrument Setting	Electronic Load Setting
Voltage Programming & Readback Min Voltage:	0 V, 1 A	N/A
Voltage Programming & Readback High Voltage:	600 V, 1 A	N/A
CV Load Effect, CV Source Effect:	600 V, 5.712 A	612 V, -5.6 A
CV Ripple and Noise: *	500 V, 5.712 A	510 V, -5.6 A
Transient Response:	600 V, 5.712 A	612 V from - 0.56 A to - 5.04 A
Current Programming & Readback Min Current:	612 V, 0 A	N/A
Current Programming & Readback High Current:	612 V, 5.6	N/A
CC Load Effect, CC Source Effect:	612 V, 5.6	600 V, - 5.712 A

\* **CAUTION** Set OVP to 110% of Instrument Voltage Rating

## Test Record Forms – 5.0 kW Models

## DP5761AL, DP5761AH

DP5761AL, DP5761AH Test Record		Report Number _____	Date _____
Test Description	Min. Specs	Results	Max. Specs
Voltage Programming & Readback (in Remote Sense)			
Minimum voltage (Vout):	- 0.005 V	_____	0.005 V
Voltage measured over interface:	Vdmm – 0.005 V	_____	Vdmm + 0.005 V
High voltage (Vout):	9.995 V	_____	10.005 V
Voltage measured over interface:	Vdmm – 0.005 V	_____	Vdmm + 0.005 V
Voltage Programming & Readback (in Local Sense)			
Minimum voltage (Vout):	- 0.005 V	_____	0.005 V
Voltage measured over interface:	Vdmm – 0.005 V	_____	Vdmm + 0.005 V
High voltage (Vout):	9.995 V	_____	10.005 V
Voltage measured over interface:	Vdmm – 0.005 V	_____	Vdmm + 0.005 V
CV Source Effect	- 0.001 V	_____	+ 0.001 V
CV Load Effect:	- 0.006 V	_____	+ 0.006 V
CV Ripple and Noise			
peak-to-peak:	N/A	_____	+ 75 mV
rms:		_____	+ 8 mV
Transient response: @ 1 ms	- 0.05 V	_____	+ 0.05 V
Current Programming & Readback			
Minimum current (Iout):	-1 A	_____	1 A
Current measured over interface:	Idmm – 1 A	_____	Idmm + 1 A
High current (Iout):	498.5 A	_____	501.5 A
Current measured over interface:	Idmm – 1 A	_____	Idmm + 1 A
CC Source Effect	- 0.25 A	_____	+ 0.25 A
CC Load Effect:	- 0.4 A	_____	+ 0.4 A

Test Description	Instrument Setting	Electronic Load Setting
Voltage Programming & Readback Min Voltage:	0 V, 1 A	N/A
Voltage Programming & Readback High Voltage:	10 V, 1 A	N/A
CV Load Effect, CV Source Effect:	10 V, 510 A	10.2 V, -500 A
CV Ripple and Noise:	10 V, 510 A	10.2 V, -500 A
Transient Response:	10 V, 510 A	10.2 V from -50 A to -450 A
Current Programming & Readback Min Current:	10.2 V, 0 A	N/A
Current Programming & Readback High Current:	10.2 V, 500 A	N/A
CC Load Effect, CC Source Effect:	10.2 V, 500 A	10 V, -510 A

**DP5762AL, DP5762AH**

DP5762AL, DP5762AH Test Record		Report Number _____	Date _____
Test Description	Min. Specs	Results	Max. Specs
Voltage Programming & Readback (in Remote Sense)			
Minimum voltage (Vout):	- 0.01 V	_____	0.01 V
Voltage measured over interface:	Vdmm - 0.01 V	_____	Vdmm + 0.01 V
High voltage (Vout):	19.99 V	_____	20.01 V
Voltage measured over interface:	Vdmm - 0.01 V	_____	Vdmm - 0.01 V
Voltage Programming & Readback (in Local Sense)			
Minimum voltage (Vout):	- 0.01 V	_____	0.01 V
Voltage measured over interface:	Vdmm - 0.01 V	_____	Vdmm + 0.01 V
High voltage (Vout):	19.99 V	_____	20.01 V
Voltage measured over interface:	Vdmm - 0.01 V	_____	Vdmm - 0.01 V
CV Source Effect	- 0.002 V	_____	+ 0.002 V
CV Load Effect:	- 0.007 V	_____	+ 0.007 V
CV Ripple and Noise			
peak-to-peak:	N/A	_____	+ 75 mV
rms:		_____	+ 10 mV
Transient response: @ 1 ms	- 0.1 V	_____	+ 0.1 V
Current Programming & Readback			
Minimum current (Iout):	- 0.5 A	_____	0.5 A
Current measured over interface:	Idmm - 0.5 A	_____	Idmm + 0.5 A
High current (Iout):	249.25 A	_____	250.75 A
Current measured over interface:	Idmm - 0.5 A	_____	Idmm + 0.5 A
CC Source Effect	- 0.125 A	_____	+ -0.125 A
CC Load Effect:	- 0.2 A	_____	+ 0.2 A

Test Description	Instrument Setting	Electronic Load Setting
Voltage Programming & Readback Min Voltage:	0 V, 1 A	N/A
Voltage Programming & Readback High Voltage:	20 V, 1 A	N/A
CV Load Effect, CV Source Effect:	20 V, 255 A	20.4 V, -250 A
CV Ripple and Noise:	20 V, 255 A	20.4 V, -250 A
Transient Response:	20 V, 255 A	20.4 V from -25 A to -225 A
Current Programming & Readback Min Current:	20.4 V, 0 A	N/A
Current Programming & Readback High Current:	20.4 V, 250 A	N/A
CC Load Effect, CC Source Effect:	20.4 V, 250 A	25 V, -255 A

## DP5763AL, DP5763AH

DP5763AL, DP5763AH Test Record		Report Number _____	Date _____
Test Description	Min. Specs	Results	Max. Specs
Voltage Programming & Readback (in Remote Sense)			
Minimum voltage (Vout):	- 0.015 V	_____	0.015 V
Voltage measured over interface:	Vdmm - 0.015 V	_____	Vdmm +0.015 V
High voltage (Vout):	29.985 V	_____	30.015 V
Voltage measured over interface:	Vdmm - 0.015 V	_____	Vdmm + 0.015 V
Voltage Programming & Readback (in Local Sense)			
Minimum voltage (Vout):	- 0.015 V	_____	0.015 V
Voltage measured over interface:	Vdmm - 0.015 V	_____	Vdmm +0.015 V
High voltage (Vout):	29.985 V	_____	30.015 V
Voltage measured over interface:	Vdmm - 0.015 V	_____	Vdmm + 0.015 V
CV Source Effect	- 0.003 V	_____	+ 0.003 V
CV Load Effect:	- 0.008 V	_____	+ 0.008 V
CV Ripple and Noise			
peak-to-peak:	N/A	_____	+ 75 mV
rms:		_____	+ 12 mV
Transient response: @ 1 ms	- 0.15 V	_____	+ 0.15 V
Current Programming & Readback			
Minimum current (Iout):	- 0.34 A	_____	0.34 A
Current measured over interface:	Idmm - 0.34 A	_____	Idmm + 0.34 A
High current (Iout):	169.49 A	_____	170.51 A
Current measured over interface:	Idmm - 0.34 A	_____	Idmm + 0.34 A
CC Source Effect	- 0.085 A	_____	+ 0.085 A
CC Load Effect:	- 0.136 A	_____	+ 0.136 A

Test Description	Instrument Setting	Electronic Load Setting
Voltage Programming & Readback Min Voltage:	0 V, 1 A	N/A
Voltage Programming & Readback High Voltage:	30 V, 1 A	N/A
CV Load Effect, CV Source Effect:	30 V, 173.4 A	30.6 V, -170 A
CV Ripple and Noise:	30 V, 173.4 A	30.6 V, -170 A
Transient Response:	30 V, 173.4 A	30.6 V from -17 A to -153 A
Current Programming & Readback Min Current:	30.6 V, 0 A	N/A
Current Programming & Readback High Current:	30.6 V, 170 A	N/A
CC Load Effect, CC Source Effect:	30.6 V, 170 A	30 V, -173.4 A

**DP5764AL, DP5764AH**

DP5764AL, DP5764AH Test Record		Report Number _____	Date _____
Test Description	Min. Specs	Results	Max. Specs
Voltage Programming & Readback (in Remote Sense)			
Minimum voltage (Vout):	- 0.02 V	_____	0.02 V
Voltage measured over interface:	Vdmm - 0.02 V	_____	Vdmm + 0.02 V
High voltage (Vout):	39.98 V	_____	40.02 V
Voltage measured over interface:	Vdmm - 0.02 V	_____	Vdmm + 0.02 V
Voltage Programming & Readback (in Local Sense)			
Minimum voltage (Vout):	- 0.02 V	_____	0.02 V
Voltage measured over interface:	Vdmm - 0.02 V	_____	Vdmm + 0.02 V
High voltage (Vout):	39.98 V	_____	40.02 V
Voltage measured over interface:	Vdmm - 0.02 V	_____	Vdmm + 0.02 V
CV Source Effect	- 0.004 V	_____	+ 0.004 V
CV Load Effect:	- 0.009 V	_____	+ 0.009 V
CV Ripple and Noise			
peak-to-peak:	N/A	_____	+ 75 mV
rms:		_____	+ 12 mV
Transient response: @ 1 ms	- 0.2 V	_____	+ 0.2 V
Current Programming & Readback			
Minimum current (Iout):	- 0.25 A	_____	0.25 A
Current measured over interface:	Idmm - 0.25 A	_____	Idmm + 0.25 A
High current (Iout):	124.625 A	_____	125.375 A
Current measured over interface:	Idmm - 0.25 A	_____	Idmm + 0.25 A
CC Source Effect	- 0.0625 A	_____	+ 0.0625 A
CC Load Effect:	- 0.1 A	_____	+ 0.1 A

Test Description	Instrument Setting	Electronic Load Setting
Voltage Programming & Readback Min Voltage:	0 V, 1 A	N/A
Voltage Programming & Readback High Voltage:	40 V, 1 A	N/A
CV Load Effect, CV Source Effect:	40 V, 127.5 A	40.8 V, -125 A
CV Ripple and Noise:	40 V, 127.5 A	40.8 V, -125 A
Transient Response:	40 V, 127.5 A	40.8 V from -12.5 A to -112.5 A
Current Programming & Readback Min Current:	40.8 V, 0 A	N/A
Current Programming & Readback High Current:	40.8 V, 125 A	N/A
CC Load Effect, CC Source Effect:	40.8 V, 125 A	40 V, -127.5 A

## DP5765AL, DP5765AH

DP5765AL, DP5765AH Test Record		Report Number _____	Date _____
Test Description	Min. Specs	Results	Max. Specs
Voltage Programming & Readback (in Remote Sense)			
Minimum voltage (Vout):	- 0.025 V	_____	0.025 V
Voltage measured over interface:	Vdmm -0.025 V	_____	Vdmm +0.025 V
High voltage (Vout):	49.975 V	_____	50.025 V
Voltage measured over interface:	Vdmm - 0.025 V	_____	Vdmm +0.025 V
Voltage Programming & Readback (in Local Sense)			
Minimum voltage (Vout):	- 0.025 V	_____	0.025 V
Voltage measured over interface:	Vdmm -0.025 V	_____	Vdmm +0.025 V
High voltage (Vout):	49.975 V	_____	50.025 V
Voltage measured over interface:	Vdmm - 0.025 V	_____	Vdmm +0.025 V
CV Source Effect	- 0.005 V	_____	+ 0.005 V
CV Load Effect:	- 0.01 V	_____	+ 0.01 V
CV Ripple and Noise			
peak-to-peak:	N/A	_____	+ 75 mV
rms:		_____	+ 12 mV
Transient response: @ 1 ms	- 0.25 V	_____	+ 0.25 V
Current Programming & Readback			
Minimum current (Iout):	- 0.2 A	_____	0.2 A
Current measured over interface:	Idmm - 0.2 A	_____	Idmm + 0.2 A
High current (Iout):	99.7 A	_____	100.3 A
Current measured over interface:	Idmm -0.2 A	_____	Idmm + 0.2 A
CC Source Effect	- 0.05 A	_____	+ 0.05 A
CC Load Effect:	- 0.08 A	_____	+ 0.08 A

Test Description	Instrument Setting	Electronic Load Setting
Voltage Programming & Readback Min Voltage:	0 V, 1 A	N/A
Voltage Programming & Readback High Voltage:	50 V, 1 A	N/A
CV Load Effect, CV Source Effect:	50 V, 102 A	51 V, -100 A
CV Ripple and Noise:	50 V, 102 A	51 V, -100 A
Transient Response:	50 V, 102 A	51 V from -10 A to -90 A
Current Programming & Readback Min Current:	51 V, 0 A	N/A
Current Programming & Readback High Current:	51 V, 100 A	N/A
CC Load Effect, CC Source Effect:	51 V, 100 A	50 V, -102 A

**DP5766AL, DP5766AH**

DP5766AL, DP5766AH Test Record		Report Number _____	Date _____
Test Description	Min. Specs	Results	Max. Specs
Voltage Programming & Readback (in Remote Sense)			
Minimum voltage (Vout):	- 0.03 V	_____	0.03 V
Voltage measured over interface:	Vdmm -0.03 V	_____	Vdmm + 0.03 V
High voltage (Vout):	59.97 V	_____	60.03 V
Voltage measured over interface:	Vdmm - 0.03 V	_____	Vdmm + 0.03 V
Voltage Programming & Readback (in Local Sense)			
Minimum voltage (Vout):	- 0.03 V	_____	0.03 V
Voltage measured over interface:	Vdmm -0.03 V	_____	Vdmm + 0.03 V
High voltage (Vout):	59.97 V	_____	60.03 V
Voltage measured over interface:	Vdmm - 0.03 V	_____	Vdmm + 0.03 V
CV Source Effect	- 0.006 V	_____	+ 0.006 V
CV Load Effect:	- 0.011 V	_____	+ 0.011 V
CV Ripple and Noise			
peak-to-peak:	N/A	_____	+ 75 mV
rms:		_____	+ 12 mV
Transient response: @ 1 ms	- 0.3 V	_____	+ 0.3 V
Current Programming & Readback			
Minimum current (Iout):	- 0.17 A	_____	0.17 A
Current measured over interface:	Idmm -0.17 A	_____	Idmm + 0.17 A
High current (Iout):	84.745 A	_____	85.255 A
Current measured over interface:	Idmm - 0.17 A	_____	Idmm + 0.17 A
CC Source Effect	- 0.0425 A	_____	+ 0.0425 A
CC Load Effect:	- 0.068 A	_____	+ 0.068 A

Test Description	Instrument Setting	Electronic Load Setting
Voltage Programming & Readback Min Voltage:	0 V, 1 A	N/A
Voltage Programming & Readback High Voltage:	60 V, 1 A	N/A
CV Load Effect, CV Source Effect:	60 V, 86.7 A	61.2 V, -85 A
CV Ripple and Noise:	60 V, 86.7 A	61.2 V, -85 A
Transient Response:	60 V, 86.7 A	61.2 V from -8.5 A to -76.5 A
Current Programming & Readback Min Current:	61.2 V, 0 A	N/A
Current Programming & Readback High Current:	61.2 V, 85 A	N/A
CC Load Effect, CC Source Effect:	61.2 V, 85 A	60 V, -86.7 A

## DP5768AL, DP5768AH

DP5768AL, DP5768AH Test Record		Report Number _____	Date _____
Test Description	Min. Specs	Results	Max. Specs
Voltage Programming & Readback (in Remote Sense)			
Minimum voltage (Vout):	- 0.04 V	_____	0.04 V
Voltage measured over interface:	Vdmm - 0.04 V	_____	Vdmm + 0.04 V
High voltage (Vout):	79.96 V	_____	80.04 V
Voltage measured over interface:	Vdmm - 0.04 V	_____	Vdmm + 0.04 V
Voltage Programming & Readback (in Local Sense)			
Minimum voltage (Vout):	- 0.04 V	_____	0.04 V
Voltage measured over interface:	Vdmm - 0.04 V	_____	Vdmm + 0.04 V
High voltage (Vout):	79.96 V	_____	80.04 V
Voltage measured over interface:	Vdmm - 0.04 V	_____	Vdmm + 0.04 V
CV Source Effect	- 0.008 V	_____	+ 0.008 V
CV Load Effect:	- 0.013 V	_____	+ 0.013 V
CV Ripple and Noise			
peak-to-peak:	N/A	_____	+ 80 mV
rms:		_____	+ 15 mV
Transient response: @ 1 ms	- 0.4 V	_____	+ 0.4 V
Current Programming & Readback			
Minimum current (Iout):	- 0.13 A	_____	0.13 A
Current measured over interface:	Idmm - 0.13 A	_____	Idmm + 0.13 A
High current (Iout):	64.805 A	_____	65.195 A
Current measured over interface:	Idmm - 0.13 A	_____	Idmm + 0.13 A
CC Source Effect	- 0.0325 A	_____	+ 0.0325 A
CC Load Effect:	- 0.052 A	_____	+ 0.052 A

Test Description	Instrument Setting	Electronic Load Setting
Voltage Programming & Readback Min Voltage:	0 V, 1	N/A
Voltage Programming & Readback High Voltage:	80 V, 1	N/A
CV Load Effect, CV Source Effect:	80 V, 66.3 A	81.6 V, -65 A
CV Ripple and Noise:	80 V, 66.3 A	81.6 V, -65 A
Transient Response:	80 V, 66.3 A	81.6 V from -6.5 A to -58.5 A
Current Programming & Readback Min Current:	81.6 V, 0 A	N/A
Current Programming & Readback High Current:	81.6 V, 65 A	N/A
CC Load Effect, CC Source Effect:	81.6 V, 65 A	50 V, -66.3 A

**DP5770AL, DP5770AH**

DP5770AL, DP5770AH Test Record		Report Number _____	Date _____
Test Description	Min. Specs	Results	Max. Specs
Voltage Programming & Readback (in Remote Sense)			
Minimum voltage (Vout):	- 0.05 V	_____	0.05 V
Voltage measured over interface:	Vdmm - 0.05 V	_____	Vdmm + 0.05 V
High voltage (Vout):	99.95 V	_____	100.05 V
Voltage measured over interface:	Vdmm - 0.05 V	_____	Vdmm + 0.05 V
Voltage Programming & Readback (in Local Sense)			
Minimum voltage (Vout):	- 0.05 V	_____	0.05 V
Voltage measured over interface:	Vdmm - 0.05 V	_____	Vdmm + 0.05 V
High voltage (Vout):	99.95 V	_____	100.05 V
Voltage measured over interface:	Vdmm - 0.05 V	_____	Vdmm + 0.05 V
CV Source Effect	- 0.01 V	_____	+ 0.01 V
CV Load Effect:	- 0.015 V	_____	+ 0.015 V
CV Ripple and Noise			
peak-to-peak:	N/A	_____	+ 90 mV
rms:		_____	+ 15 mV
Transient response: @ 1 ms	- 0.5 V	_____	+ 0.5 V
Current Programming & Readback			
Minimum current (Iout):	- 0.1 A	_____	0.1 A
Current measured over interface:	Idmm - 0.1 A	_____	Idmm + 0.1 A
High current (Iout):	49.85 A	_____	50.15 A
Current measured over interface:	Idmm - 0.1 A	_____	Idmm + 0.1 A
CC Source Effect	- 0.025 A	_____	+ 0.025 A
CC Load Effect:	- 0.04 A	_____	+ 0.04 A

Test Description	Instrument Setting	Electronic Load Setting
Voltage Programming & Readback Min Voltage:	0 V, 1 A	N/A
Voltage Programming & Readback High Voltage:	100 V, 1 A	N/A
CV Load Effect, CV Source Effect:	100 V, 51 A	102 V, -50 A
CV Ripple and Noise:	100 V, 51 A	102 V, -50 A
Transient Response:	100 V, 51 A	102 V from -5 A to -45 A
Current Programming & Readback Min Current:	102 V, 0 A	N/A
Current Programming & Readback High Current:	102 V, 50 A	N/A
CC Load Effect, CC Source Effect:	102 V, 50 A	100 V, -51 A

## DP5771AL, DP5771AH

DP5771AL, DP5771AH Test Record		Report Number _____	Date _____
Test Description	Min. Specs	Results	Max. Specs
Voltage Programming & Readback (in Remote Sense)			
Minimum voltage (Vout):	- 0.075 V	_____	0.075 V
Voltage measured over interface:	Vdmm - 0.075 V	_____	Vdmm + 0.075 V
High voltage (Vout):	149.925 V	_____	150.075 V
Voltage measured over interface:	Vdmm - 0.075 V	_____	Vdmm + 0.075 V
Voltage Programming & Readback (in Local Sense)			
Minimum voltage (Vout):	- 0.075 V	_____	0.075 V
Voltage measured over interface:	Vdmm - 0.075 V	_____	Vdmm + 0.075 V
High voltage (Vout):	149.925 V	_____	150.075 V
Voltage measured over interface:	Vdmm - 0.075 V	_____	Vdmm + 0.075 V
CV Source Effect	- 0.015 V	_____	+ 0.015 V
CV Load Effect:	- 0.02 V	_____	+ 0.02 V
CV Ripple and Noise			
peak-to-peak:	N/A	_____	+ 120 mV
rms:		_____	+ 20 mV
Transient response: @ 2 ms	- 0.75 V	_____	+ 0.75 V
Current Programming & Readback			
Minimum current (Iout):	- 0.068 A	_____	0.068 A
Current measured over interface:	Idmm - 0.068 A	_____	Idmm + 0.068 A
High current (Iout):	33.898 A	_____	34.102 A
Current measured over interface:	Idmm - 0.068 A	_____	Idmm + 0.068 A
CC Source Effect	- 0.017 A	_____	+ 0.017 A
CC Load Effect:	- 0.0272 A	_____	+ 0.0272 A

Test Description	Instrument Setting	Electronic Load Setting
Voltage Programming & Readback Min Voltage:	0 V, 1 A	N/A
Voltage Programming & Readback High Voltage:	150 V, 1 A	N/A
CV Load Effect, CV Source Effect:	150 V, 34.68 A	153 V, -34 A
CV Ripple and Noise:	150 V, 34.68 A	153 V, -34 A
Transient Response:	150 V, 34.68 A	153 V from -3.4 A to -30.6 A
Current Programming & Readback Min Current:	153 V, 0 A	N/A
Current Programming & Readback High Current:	153 V, 34 A	N/A
CC Load Effect, CC Source Effect:	153 V, 34 A	150 V, -34.68 A

**DP5772AL, DP5772AH**

DP5772AL, DP5772AH Test Record		Report Number _____	Date _____
Test Description	Min. Specs	Results	Max. Specs
Voltage Programming & Readback (in Remote Sense)			
Minimum voltage (Vout):	- 0.1 V	_____	0.1 V
Voltage measured over interface:	Vdmm - 0.1 V	_____	Vdmm + 0.1 V
High voltage (Vout):	199.9 V	_____	200.1 V
Voltage measured over interface:	Vdmm - 0.1 V	_____	Vdmm + 0.1 V
Voltage Programming & Readback (in Local Sense)			
Minimum voltage (Vout):	- 0.1 V	_____	0.1 V
Voltage measured over interface:	Vdmm - 0.1 V	_____	Vdmm + 0.1 V
High voltage (Vout):	199.9 V	_____	200.1 V
Voltage measured over interface:	Vdmm - 0.1 V	_____	Vdmm + 0.1 V
CV Source Effect	- 0.02 V	_____	+ 0.02 V
CV Load Effect:	- 0.025 V	_____	+ 0.025 V
CV Ripple and Noise			
peak-to-peak:	N/A	_____	+ 200 mV
rms:		_____	+ 45 mV
Transient response: @ 2 ms	- 1 V	_____	+ 1 V
Current Programming & Readback			
Minimum current (Iout):	- 0.05 A	_____	0.05 A
Current measured over interface:	Idmm - 0.05 A	_____	Idmm + 0.05 A
High current (Iout):	24.925 A	_____	25.075 A
Current measured over interface:	Idmm - 0.05 A	_____	Idmm + 0.05 A
CC Source Effect	- 0.0125 A	_____	+ 0.0125 A
CC Load Effect:	- 0.02 A	_____	+ 0.02 A

Test Description	Instrument Setting	Electronic Load Setting
Voltage Programming & Readback Min Voltage:	0 V, 1 A	N/A
Voltage Programming & Readback High Voltage:	200 V, 1 A	N/A
CV Load Effect, CV Source Effect:	200 V, 25.5 A	204 V, -25 A
CV Ripple and Noise:	200 V, 25.5 A	204 V, -25 A
Transient Response:	200 V, 25.5 A	204 V from -2.5 A to -22.5 A
Current Programming & Readback Min Current:	204 V, 0 A	N/A
Current Programming & Readback High Current:	204 V, 25 A	N/A
CC Load Effect, CC Source Effect:	204 V, 25 A	200 V, -25.5 A

## DP5773AL, DP5773AH

DP5773AL, DP5773AH Test Record		Report Number _____	Date _____
Test Description	Min. Specs	Results	Max. Specs
Voltage Programming & Readback (in Remote Sense)			
Minimum voltage (Vout):	- 0.15 V	_____	0.15 V
Voltage measured over interface:	Vdmm - 0.15 V	_____	Vdmm + 0.15 V
High voltage (Vout):	299.85 V	_____	300.15 V
Voltage measured over interface:	Vdmm - 0.15 V	_____	Vdmm + 0.15 V
Voltage Programming & Readback (in Local Sense)			
Minimum voltage (Vout):	- 0.15 V	_____	0.15 V
Voltage measured over interface:	Vdmm - 0.15 V	_____	Vdmm + 0.15 V
High voltage (Vout):	299.85 V	_____	300.15 V
Voltage measured over interface:	Vdmm - 0.15 V	_____	Vdmm + 0.15 V
CV Source Effect	- 0.03 V	_____	+ 0.03 V
CV Load Effect:	- 0.035 V	_____	+ 0.035 V
CV Ripple and Noise			
peak-to-peak:	N/A	_____	+ 200 mV
rms:		_____	+ 60 mV
Transient response: @ 2 ms	- 1.5 V	_____	+ 1.5 V
Current Programming & Readback			
Minimum current (Iout):	- 0.034 A	_____	0.034 A
Current measured over interface:	Idmm - 0.034 A	_____	Idmm + 0.034 A
High current (Iout):	16.949 A	_____	17.051 A
Current measured over interface:	Idmm - 0.034 A	_____	Idmm + 0.034 A
CC Source Effect	- 0.0085 A	_____	+ 0.0085 A
CC Load Effect:	- 0.0136 A	_____	+ 0.0136 A

Test Description	Instrument Setting	Electronic Load Setting
Voltage Programming & Readback Min Voltage:	0 V, 1 A	N/A
Voltage Programming & Readback High Voltage:	300 V, 1 A	N/A
CV Load Effect, CV Source Effect:	300 V, 17.34 A	306 V, -17 A
CV Ripple and Noise:	300 V, 17.34 A	306 V, -17 A
Transient Response:	300 V, 17.34 A	306 V from -1.7 A to -15.3 A
Current Programming & Readback Min Current:	306 V, 0 A	N/A
Current Programming & Readback High Current:	306 V, 17 A	N/A
CC Load Effect, CC Source Effect:	306 V, 17 A	300 V, -17.34 A

**DP5774AL, DP5774AH**

DP5774AL, DP5774AH Test Record		Report Number _____	Date _____
Test Description	Min. Specs	Results	Max. Specs
Voltage Programming & Readback (in Remote Sense)			
Minimum voltage (Vout):	- 0.2 V	_____	0.2 V
Voltage measured over interface:	Vdmm - 0.2 V	_____	Vdmm + 0.2 V
High voltage (Vout):	399.8 V	_____	400.2 V
Voltage measured over interface:	Vdmm - 0.2 V	_____	Vdmm + 0.2 V
Voltage Programming & Readback (in Local Sense)			
Minimum voltage (Vout):	- 0.2 V	_____	0.2 V
Voltage measured over interface:	Vdmm - 0.2 V	_____	Vdmm + 0.2 V
High voltage (Vout):	399.8 V	_____	400.2 V
Voltage measured over interface:	Vdmm - 0.2 V	_____	Vdmm + 0.2 V
CV Source Effect	- 0.04 V	_____	+ 0.04 V
CV Load Effect:	- 0.045 V	_____	+ 0.045 V
CV Ripple and Noise			
peak-to-peak:	N/A	_____	+ 400 mV
rms:		_____	+ 80 mV
Transient response: @ 2 ms	- 2 V	_____	+ 2 V
Current Programming & Readback			
Minimum current (Iout):	- 0.026 A	_____	0.026 A
Current measured over interface:	Idmm - 0.026 A	_____	Idmm +0.026 A
High current (Iout):	12.961 A	_____	13.039 A
Current measured over interface:	Idmm -0.026 A	_____	Idmm +0.026 A
CC Source Effect	- 0.0065 A	_____	+ 0.0065 A
CC Load Effect:	- 0.0104 A	_____	+ 0.0104 A

Test Description	Instrument Setting	Electronic Load Setting
Voltage Programming & Readback Min Voltage:	0 V, 1 A	N/A
Voltage Programming & Readback High Voltage:	400 V, 1 A	N/A
CV Load Effect, CV Source Effect:	400 V, 13.26 A	408 V, -13 A
CV Ripple and Noise:	400 V, 13.26 A	408 V, -13 A
Transient Response:	400 V, 13.26 A	408 V from -1.3 A to -11.7 A
Current Programming & Readback Min Current:	408 V, 0 A	N/A
Current Programming & Readback High Current:	408 V, 13 A	N/A
CC Load Effect, CC Source Effect:	408 V, 13 A	400 V, -13.26 A

## DP5775AL, DP5775AH

DP5775AL, DP5775AH Test Record		Report Number _____	Date _____
Test Description	Min. Specs	Results	Max. Specs
Voltage Programming & Readback (in Remote Sense)			
Minimum voltage (Vout):	- 0.25 V	_____	0.25 V
Voltage measured over interface:	Vdmm - 0.25 V	_____	Vdmm + 0.25 V
High voltage (Vout):	499.75 V	_____	500.25 V
Voltage measured over interface:	Vdmm - 0.25 V	_____	Vdmm + 0.25 V
Voltage Programming & Readback (in Local Sense)			
Minimum voltage (Vout):	- 0.25 V	_____	0.25 V
Voltage measured over interface:	Vdmm - 0.25 V	_____	Vdmm + 0.25 V
High voltage (Vout):	499.75 V	_____	500.25 V
Voltage measured over interface:	Vdmm - 0.25 V	_____	Vdmm + 0.25 V
CV Source Effect	- 0.05 V	_____	+ 0.05 V
CV Load Effect:	- 0.055 V	_____	+ 0.055 V
CV Ripple and Noise			
peak-to-peak:	N/A	_____	+ 450 mV
rms:		_____	+ 80 mV
Transient response: @ 2 ms	- 2.5 V	_____	+ 2.5 V
Current Programming & Readback			
Minimum current (Iout):	- 0.02 A	_____	0.02 A
Current measured over interface:	Idmm - 0.02 A	_____	Idmm + 0.02 A
High current (Iout):	9.97 A	_____	10.03 A
Current measured over interface:	Idmm - 0.02 A	_____	Idmm + 0.02 A
CC Source Effect	- 0.005 A	_____	+ 0.005 A
CC Load Effect:	- 0.008 A	_____	+ 0.008 A

Test Description	Instrument Setting	Electronic Load Setting
Voltage Programming & Readback Min Voltage:	0 V, 1 A	N/A
Voltage Programming & Readback High Voltage:	500 V, 1 A	N/A
CV Load Effect, CV Source Effect:	500 V, 10.2 A	510 V, -10 A
CV Ripple and Noise: *	500 V, 10.2 A	510 V, -10 A
Transient Response:	500 V, 10.2 A	510 V from -1 A to -9 A
Current Programming & Readback Min Current:	510 V, 0 A	N/A
Current Programming & Readback High Current:	510 V, 10 A	N/A
CC Load Effect, CC Source Effect:	510 V, 10 A	500 V, -10.2 A

\* **CAUTION** Set OVP to 110% of Instrument Voltage Rating

**DP5776AL, DP5776AH**

DP5776AL, DP5776AH Test Record		Report Number _____	Date _____
Test Description	Min. Specs	Results	Max. Specs
Voltage Programming & Readback (in Remote Sense)			
Minimum voltage (Vout):	- 0.3 V	_____	0.3 V
Voltage measured over interface:	Vdmm - 0.3 V	_____	Vdmm + 0.3 V
High voltage (Vout):	599.7 V	_____	600.3 V
Voltage measured over interface:	Vdmm - 0.3 V	_____	Vdmm + 0.3 V
Voltage Programming & Readback (in Local Sense)			
Minimum voltage (Vout):	- 0.3 V	_____	0.3 V
Voltage measured over interface:	Vdmm - 0.3 V	_____	Vdmm + 0.3 V
High voltage (Vout):	599.7 V	_____	600.3 V
Voltage measured over interface:	Vdmm - 0.3 V	_____	Vdmm + 0.3 V
CV Source Effect	- 0.06 V	_____	+ 0.06 V
CV Load Effect:	- 0.065 V	_____	+ 0.065 V
CV Ripple and Noise			
peak-to-peak:	N/A	_____	+ 480 mV
rms:		_____	+ 100 mV
Transient response: @ 2 ms	- 3 V	_____	+ 3 V
Current Programming & Readback			
Minimum current (Iout):	- 0.017 1 A	_____	0.017 A
Current measured over interface:	Idmm - 0.017 A	_____	Idmm + 0.017 A
High current (Iout):	8.4745 A	_____	8.5255 A
Current measured over interface:	Idmm - 0.017 A	_____	Idmm + 0.017 A
CC Source Effect	- 0.00425 A	_____	+ 0.00425 A
CC Load Effect:	- 0.0068 A	_____	+ 0.0068 A

Test Description	Instrument Setting	Electronic Load Setting
Voltage Programming & Readback Min Voltage:	0 V, 1 A	N/A
Voltage Programming & Readback High Voltage:	600 V, 1 A	N/A
CV Load Effect, CV Source Effect:	600 V, 8.67 A	612 V, -8.5 A
CV Ripple and Noise: *	500 V, 8.67 A	510 V, -8.5 A
Transient Response:	600 V, 8.67 A	612 V from -0.85 A to -7.65 A
Current Programming & Readback Min Current:	612 V, 0 A	N/A
Current Programming & Readback High Current:	612 V, 8.5 A	N/A
CC Load Effect, CC Source Effect:	612 V, 8.5 A	600 V, -8.67 A

\* **CAUTION** Set OVP to 110% of Instrument Voltage Rating

# Index

**\***

\*CLS 118

\*ESE 118

\*ESR? 119

\*IDN? 119

\*OPC 120

\*OPC? 120

\*OPT? 120

\*RCL 121

\*RST 121

\*SAV 122

\*SRE 122

\*STB? 123

\*TST? 124

\*WAI 124

## **A**

Abort 117

Air flow 183

Analog 117

## **C**

Clear Status 160

CLS 118, 160

command language

    quick reference 113

Command

    Separators 107

Command

    Terminators 107

communication remote  
    interface 95

Current 70

CURRent 125-126

    SLEW 127

## **D**

DIGital 127-128

Display

    lockout 93

DISPlay 128

DISPlay Subsystem Intro-  
    duction 128

## **E**

End-Or-Identify 108

Environment 33

Error Messages 160

ESE 118

ESR? 119

## **F**

Factory Reset 121, 160

Ferrite Core

    Installation 50

FIFO 160

First-in-first-out 160

front panel 21, 23

front-panel

    menus 26, 50

## **G**

GPIB 160

## **I**

I/O 160

    queue 160

IDN? 119

IEEE\_488 Common

    commands 118

INITiate Subsystem Intro-  
    duction 129

Inspect 30

INSTrument Subsystem  
    Introduction 130

Introduction 106

    SCPI Language 106

## **K**

Keywords 107

## **L**

LIST

    CURRent 131

    POINTs? 132

    DWELL 132

    STEP 132

VOLTage 131  
    POINTs? 132  
LIST Subsystem Intro-  
duction 131  
LXI  
    IDENTify 133  
LXI Commands 133

## M

MEASure 134  
menus 26  
Message Available 122-123

## N

Non-Volatile Settings 158

## O

OPT? 120  
OUTPut 135  
over current 74  
over current local 74  
over temperature 74  
over voltage 74

## P

Parameter Types 109  
POWER 138

## Q

Queries 107

Querying  
    Status Byte Register 123  
Questionable Data Sum-  
mary 122-123  
Queue 160  
    I/O 160  
Quick command  
reference 113

## R

Rack mounting 34  
RCL 121  
rear panel 24  
REFerence 113  
remote interface 95  
Reset State 158  
RST 121

## S

Safety 33  
Safety Notices 9  
SAV 122  
SCPI 106  
    quick reference 113  
SCPI Language 106  
    Introduction 106  
SCPI Status System 160  
Self-test 124  
Set output current 70  
SLEW 138

SRE 122  
Standard Event  
    Summary 122-123  
Standard Operation  
    Register 122-123  
Standard Operation Sum-  
mary 122-123  
STATus 141  
Status Byte 122  
Status Byte Register 122-  
123  
Status System Diagram 139  
STB? 123  
Syntax Conventions 108  
SYSTem 146

## T

TRIGger Subsystem Intro-  
duction 153  
TST? 124

## U

Using Device Clear 110

## V

Verification 167, 191  
    test equipment 189  
VOLTage 154  
    SLEW 157

W

WAI 124

